

WARING PRO™

PROFESSIONAL CONVECTION OVEN INSTRUCTION/RECIPE BOOK

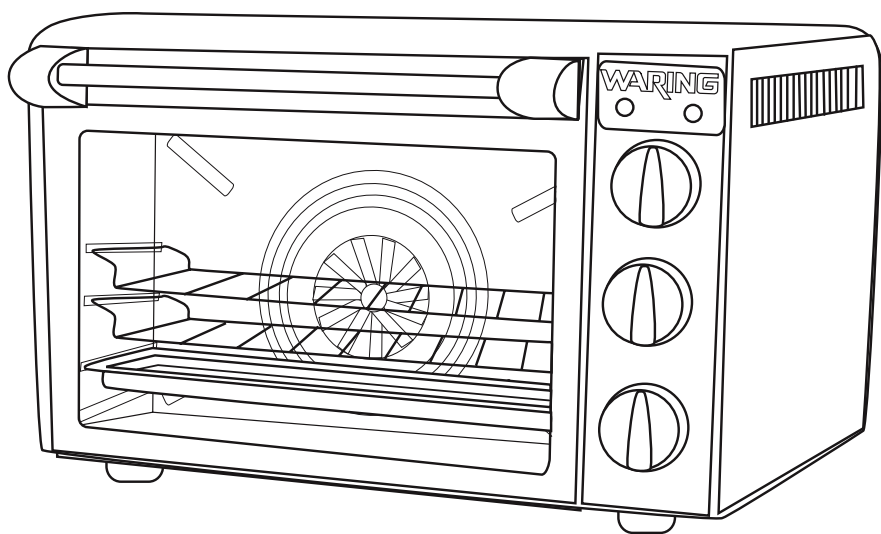

MODEL CO1500B
1.5 cu. ft.

For your safety and continued enjoyment of this product,
always read the instruction book carefully before using.

IMPORTANT SAFEGUARDS

When using electrical appliances, basic safety precautions should always be followed to reduce the risk of fire, electric shock and/or injury to persons, including the following:

READ ALL INSTRUCTIONS

1. To protect against risk of electrical shock, do not put appliance in water or other liquid.
2. When using the handle or a knob during the cooking process, do not touch the glass surface. It may be very hot.
3. This appliance should not be used by or near children, or individuals with certain disabilities.
4. **UNPLUG FROM OUTLET WHEN NOT IN USE, before putting on or taking off parts AND BEFORE CLEANING.** Allow to cool before cleaning or handling.
5. Avoid contact with moving parts.
6. The oven must be kept at a distance of 4" or more away from other objects around it in order to avoid heat damage to adjacent items.
7. Do not operate any appliance with a damaged cord or plug, or after the appliance has malfunctioned or has been dropped or damaged in any way, or is not operating properly. Return the convection oven to the nearest authorized service facility for examination, repair, or mechanical or electrical adjustment.
8. Do not let the cord hang over the edge of the table or countertop where it could be pulled on inadvertently by children or pets or touch hot surfaces, which could damage the cord.
9. The use of attachments not recommended or sold by Waring may cause fire, electric shock, or injury.
10. Do not use outdoors.
11. Do not place convection oven on or near a hot gas or electric burner or in a heated oven.
12. Do not use this convection oven for anything other than its intended purpose.

13. Always attach plug to appliance first, then plug cord into the wall outlet. To disconnect, turn any control to OFF, then remove plug from wall outlet.
14. Extreme caution should be exercised when using containers constructed of the following materials in the oven: paper, cardboard, plastic or similar products.
15. To avoid burns, use extreme caution when removing tray or disposing of hot grease.
16. Do not cover baking tray or any part of the oven with metal foil. This will cause overheating of the oven.
17. Oversize foods, metal foil packages and utensils must not be inserted in the oven/broiler as they may involve a risk of fire or electric shock.
18. A fire may occur if the convection oven is covered or touching flammable material, such as curtains, draperies, and walls, when in operation.
19. Do not store any items on top of the appliance when in operation. Do not operate under wall cabinets.
20. Do not clean with metal scouring pads. Pieces can break off the pad and touch electrical parts, involving a risk of electric shock.
21. Do not attempt to dislodge food when the convection oven is plugged into electrical outlet.
22. Warning: To avoid possibility of fire, NEVER leave oven broiler unattended during use.
23. Use recommended temperature settings for baking and roasting.
24. The appliance is off when the Timer control is in the OFF position.
25. Do not rest cooking utensils or baking dishes on glass door.

**SAVE THESE INSTRUCTIONS
FOR HOUSEHOLD AND
COMMERCIAL USE**

CONTENTS

Important Safeguards	2
Grounding Instructions	4
Short Cord Instructions.	5
Introduction	6
Parts and Accessories	6
Before Using Your Oven	10
Function Guidelines	11
Bake	11
Convection Bake	11
Rotisserie	12
Trussing A Chicken	13
Roast	15
Broil	15
Bakeware Reference Guide	16
Oven Rack Position Diagram	16
Tips and Hints	17
Brining	18
Finished Cooking Temperatures.	19
Use and Care.	20
Reference Charts with Recommended Times and Temperatures for Typical Foods	23–24
Recipes	25

GROUNDING INSTRUCTIONS

For your protection, the Waring Pro™ Professional Convection oven is supplied with a molded 3-prong grounding-type plug and should be used in combination with a properly connected grounding-type outlet as shown in figure 1. If a grounding-type outlet is not available, an adapter, shown in Figure 2, may be obtained

so that a 2-slot wall outlet can be used with a 3-prong plug. As shown in Figure 3, the adapter must be grounded by attaching its grounding lug under the screw of the outlet cover plate. **CAUTION:** Before using an adapter, it must be determined that the outlet cover plate screw is properly grounded. If in doubt, consult a licensed electrician. Never use an adapter unless you are sure it is properly grounded. **NOTE:** Use of an adapter is not permitted in Canada.

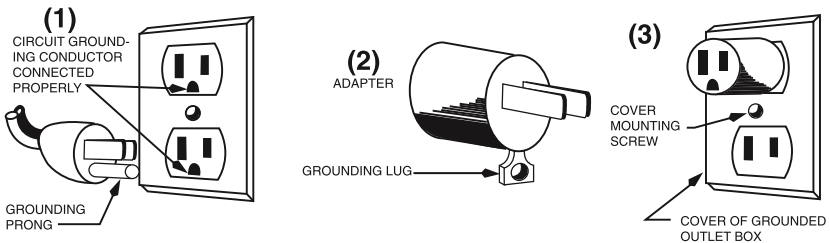

SHORT CORD INSTRUCTION

1. A short power-supply cord (or detachable power-supply cord) should be used to reduce the risk resulting from becoming entangled in or tripping over a longer cord.
2. Longer detachable power-supply cords or extension cords are available and may be used if care is exercised in their use.
3. If a longer detachable power-supply cord or extension cord is used:
 - a. The marked electrical rating of the cord set or extension cord should be at least as great as the electrical rating of the appliance; and
 - b. The cord should be arranged so that it will not drape over the countertop or tabletop where it can be pulled on by children or tripped over unintentionally.

If the appliance is of the grounded type, the extension cord should be a grounding-type 3-wire cord.

INTRODUCTION

The Waring Pro™ Convection Oven takes countertop cooking to a whole new level. Convection baking uses a hot air fan to circulate heated air, maintaining the selected temperature throughout the oven cavity. This constant flow of air eliminates the hot and cold spots often found in conventional ovens. Because the temperature remains consistent, you can set this oven approximately 25° lower than a conventional oven when using convection bake, thus saving energy. Cooking time is also reduced by approximately 25 to 30%. Use your convection oven to roast meat or whole chickens, bake cakes, cookies and more. Safe and easy to use. Exceptionally quick to clean. It's a better way to cook!

PARTS AND ACCESSORIES

- 1. Timer
- 2. Power Indicator Light – Red
- 3. Oven Temperature “Ready” Indicator Light – Green
- 4. Function Control Knob
- 5. Temperature Control Knob
- 6. Wire Racks
- 7. Handgrip
- 8. Rotisserie Spit
- 9. Rotisserie Skewers
- 10. Upper Heating Elements
- 11. Rotisserie Sockets
- 12. Rack Support Guides
- 13. Lower Heating Elements
- 14. Door Handle
- 15. Glass Door
- 16. Baking Tray
- 17. Interior Light (not shown)
- 18. Convection Fan

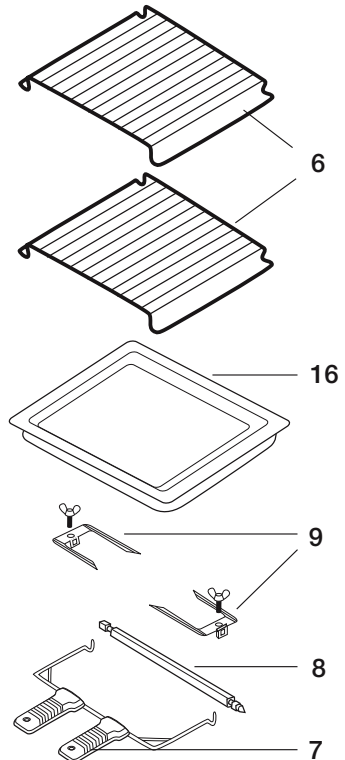

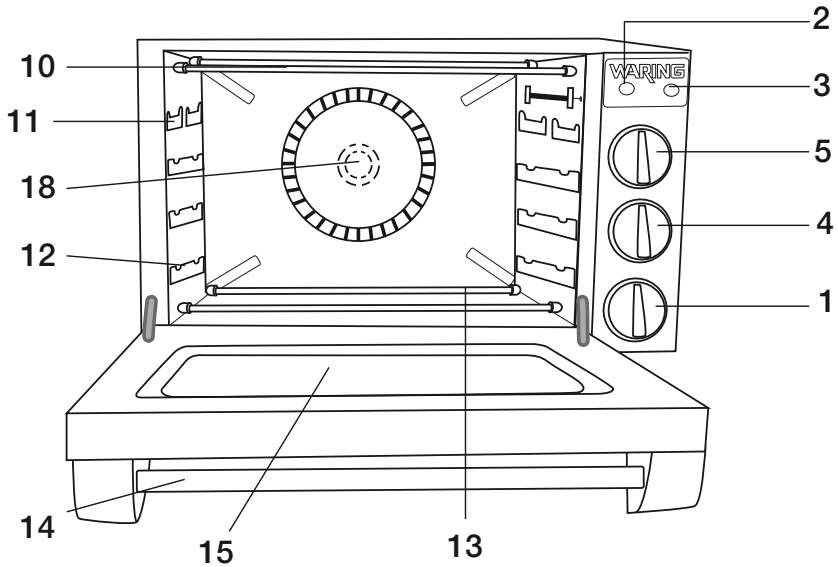

1. Timer

The range of the timer is 120 minutes. The timer setting is optional. You can set the timer either to the desired cooking time or to the OVEN ON position, which will turn the oven on. If the baking time is less than 20 minutes, first turn the timer clockwise past the 20-minute mark and turn it back to the desired time. If a longer time is required, turn the timer directly to the desired time.

2. Power Indicator Light – Red

- When the red power indicator light is on, the oven is in operation.
- When the timer is in the OFF position, the red indicator light will be off and the oven is in the OFF mode.

3. Oven Temperature “Ready” Indicator Light – Green

- When the green oven temperature "ready" indicator light is on, the oven has reached the indicated temperature.
- When broiling, "ready" indicator light will not be lit.
- The "ready" light will cycle on and off as the set temperature is maintained.

4. **Function Control Knob and General Function Guidelines**

This selector offers five choices of cooking options:

Bake

Indicates that bottom and top straight heating elements are operating. The fan is off. This mode is used for conventional baking.

Convection Bake

Indicates that the bottom and rear heating elements as well as the convection fan are operating. *This function is time-effective and efficient. It is perfect for baking most types of pastries, cookies, and for baking pizza, bread, soufflés, casseroles, as well as roasting poultry, pork and steaks.*

Rotisserie

Indicates that the rotisserie motor is operating and all 3 top heating elements are operating. *Rotisserie can be used for poultry, pork, beef filets, lamb and veal.*

Roast

Indicates that the top straight elements and bottom heating elements as well as the convection fan are operating. *This function is used for roasting chicken, pork and steaks.*

Broil

Indicates that all the top heating elements are operating. *Broil can be used for beef sirloin, hamburgers, chicken breasts, lamb chops, pork chops, fish fillets and steaks.*

5. **Temperature Control Knob**

This thermostatic switch controls the temperature inside the oven; it maintains the proper temperature during the various heating, roasting and baking operations.

6. Wire Racks

The wire racks are made of chrome-plated steel. The racks support food during broiling, roasting and baking.

7. Handgrip

To be used for removing rotisserie items from rotisserie sockets.

8. Rotisserie Spit

Food item for rotisserie should be skewered onto rotisserie spit.

9. Rotisserie Skewers

The rotisserie can be used to rotisserie larger items such as chicken, or large pieces of meat, etc. The rotisserie skewers are to be used to secure the food item for rotisserie into position.

10. Upper Heating Elements

There are two straight and one U-shaped electric heating elements in the upper part of the oven.

11. Rotisserie Sockets

The rotisserie sockets are located on the left and right wall in the center of the oven.

12. Rack Support Guides

There are four different levels inside the oven for the toasting rack and baking tray. Select the best position for the food relative to the heating elements.

13. Lower Heating Elements

There are two straight electric heating elements in the lower part of the oven.

14. Door Handle

Use this handle to avoid getting burned by the hot oven door.

15. Tempered-Glass Door

Be sure the safety door is closed tightly while preheating, baking or roasting. To avoid getting burned, don't touch the door when the oven is in use. Wait until the oven cools before cleaning the door with a damp cloth.

16. Baking Tray

Can be used for baking or as a drip tray.

17. Interior Light (not shown)

18. Rear Heating Element Circular type

BEFORE USING YOUR OVEN

Before using your oven for the first time, be sure to:

- Wash the handle, wire racks, baking tray, rotisserie spit and skewers with soapy water, rinse with clear water and dry.
- Use a damp cloth to lightly wipe the inner walls of the oven. Use a small amount of detergent, but don't use a spray or abrasive polishing agent. Do not touch the electric heating tubes and do not soak the inside of the oven with water.
- Place the wire racks, baking tray and rotisserie spit and skewers inside the oven.
- Preheat the oven. First close the oven door and then preheat the oven at the highest temperature for a minimum of 5 minutes. The oven may emit an odor. This is normal and should dissipate. **NOTE:** This odor is not harmful.
- Turn off the heating elements. Remove any smoke residue inside the oven with a damp cloth.
- Do not block the exhaust vents.

FUNCTION GUIDELINES

Bake

Your convection oven is equipped with two wire racks and has four rack positions (see diagram, page 17). The racks can be easily removed and arranged at various levels. For best results when using the oven for conventional baking, do not use more than one rack at a time.

- Set the Function knob to Bake.
- Set the Temperature knob as specified in reference chart or according to your recipe.
- Set the Timer, if desired, for up to 1 hour and 20 minutes. If the baking time is less than 20 minutes, first turn the timer clockwise past the 20-minute mark and turn it back to the desired time. If a longer baking time is required, turn the timer directly to the desired time.
- If not using the timer, set timer to OVEN ON position.
- Always use a potholder or oven mitt when removing hot food from the oven.

NOTE: Layer cake mixes can be baked one layer at a time in an 8- or 9-inch round pan or all of the mix in a 3-inch deep, 9-inch round bundt or springform pan.

Convection Bake

The general rule for using most regular baking recipes with a convection oven is to reduce the temperature given in the recipe by 25°. For roasting larger items such as meats or roasts, use the same temperature as indicated, but reduce the cooking time.

In any case, always check your baked items 10 minutes before cooking time indicates. For larger roasted items such as meats, start checking 20 to 40 minutes before stated cooking time is reached.

With convection baking, the key is the airflow. Avoid using baking dishes with high sides. For example, even when baking cookies, try to use a cookie sheet with no sides. For roasting meats use shallow baking trays as opposed to large, high-sided roasting pans. For the same reason you'll want to avoid cooking anything with a lid when you use the convection feature as the lid blocks the airflow.

- Set the Function knob to Convection Bake.
- Set the Temperature knob to the desired level.
- Set the Timer, if desired. If the baking time is less than 20 minutes, first turn the timer clockwise past the 20-minute mark and turn it back to the desired time.

If a longer baking time is required, turn the timer directly to the desired time. If not using the timer set timer to OVEN ON position.

- If required to catch drips, place the baking tray one level below the wire rack. The tray and the rack should be set at different levels for satisfactory air convection.
- When you are using the baking tray, in particular in position 1 (bottom rack position), make sure the tray is centered so that you have an air passage-way in the back as well as the front of the oven.
- Always use a potholder or oven mitt when removing hot food from the oven.
- See Reference Charts on pages 23–25 for recommended times and oven temperatures.
- Please note that the heating elements work in conjunction with the convection fan. They will cycle on and off simultaneously.

Rotisserie

When using the rotisserie function always use the baking tray lined with foil in position 1 (bottom rack position)

to catch any drips. When using the rotisserie function, always begin with a cold oven.

Tying meats ensures even cooking. It is important to use butcher's twine to tie items that are to be prepared for the rotisserie function before securing them to rotisserie spit. First tie the items and then secure the rotisserie spit and skewers.

It is especially crucial to truss all poultry with butcher's twine before securing to rotisserie spit.

Trussing a chicken

There are different methods of trussing but all are basically designed to achieve the same results.

Tuck the wings underneath the chicken to secure them. For trussing, use a length of butcher's twine that is approximately 4 or 5 times the length of the chicken. Place the middle of the twine under the tail, bring both sides up and cross over the top of the tail. Wrap ends of the twine around the end of each drumstick and pull to draw the legs together, crossing ends over each other again.

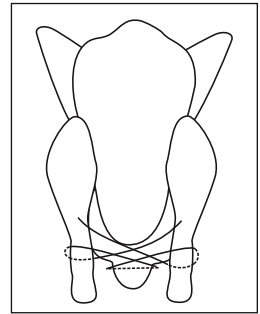

Turn the bird over. Pull ends of twine up over the thighs and wrap around the upper wings, catching the tips of the wings in the loop. The twine is wrapped around the wing close to the body, and then both ends are brought to the upper side. If there is a flap of skin at the neck, it is folded up and the two ends of twine are tied over it.

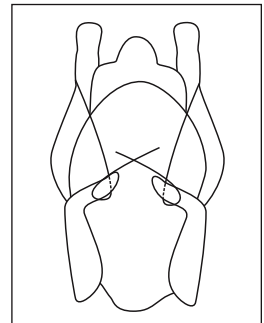

To ensure a crispy skin, leave oven door ajar for last 15 minutes of cooking time.

Please follow diagrams below when using the rotisserie function.

1. First insert the rotisserie spit into the food for rotisserie (Fig 1).

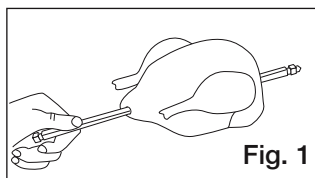

2. Insert the skewers at different angles to hold the food more firmly (Fig. 2).

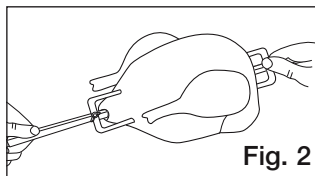

3. Next, install the fixing screws to secure the meat or poultry to the rotisserie spit.

4. Place rotisserie spit with food affixed into cold oven. **NOTE:** The ends of the rotisserie spit are marked with L for left side and R for right side of oven. Use this as a guide for inserting into rotisserie sockets.

5. Set the Function knob to Rotisserie.

6. Set the temperature to 400°F or as specified in recipe.

7. Set the timer, if desired. If the baking time is less than 20 minutes, first turn the timer clockwise past the 20-minute mark and turn it back to the desired time. If a longer baking time is required, turn the timer directly to the desired time. If not using the timer set, timer to OVEN ON position.

8. Use handgrip to remove rotisserie item from oven (see Fig. 3).

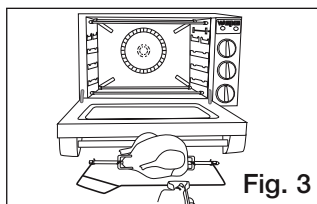

To Remove

9. Always use a potholder or oven mitt when removing hot food from the oven.
10. **NOTE:** It is recommended to add an extra 10 minutes of cooking time to allow for preheating of oven.

Please refer to the Rotisserie chart on page 23 for specific cooking times.

Roast

- Set the Function knob to Roast.
- Set the temperature to the desired level.
- Set the time, if desired.
- If required to catch drips, place the baking tray one level below the toasting rack. The tray and the rack should be set at different levels for satisfactory air convection.
- Always use a potholder or oven mitt when removing hot food from the oven.
- See Convection/Conventional Oven Cooking Times chart on page 23 for recommended roasting times and oven temperatures.
- Please note that the heating elements work in conjunction with the convection fan. They will cycle on and off simultaneously.

Broil

- Set the Function knob to Broil.
- Set the timer, if desired. If the broiling time is less than 20 minutes, first turn the timer clockwise past the 20-minute mark and turn it back to the desired time. If a longer broiling time is required, turn the timer directly to the desired time.
- Set the temperature to 500°F or as directed in recipe.
- Keep door ajar 1 to 2 inches.
- Set rack in position #3 or desired position.
- See Broiling Times chart on page 23 for recommended broiling times.

BAKEWARE REFERENCE GUIDE

The following bakeware is suitable for the 1.5 cubic foot oven when using one rack:

13 x 9	Rectangle
12 x 7½	Rectangle
11 x 7	Rectangle
9 x 13 x 2	6 Muffin
9 x 13	12 Muffin, Traditional
8 x 8 x 2	Cake, Traditional
10 x 5 x 3½	1½ lb. Loaf Pan, Traditional
8½ x 4½ x 2¾	1 lb. Loaf, Nonstick
8 x 2	Round Cake, Nonstick
9 x 2	Round Cake, Traditional
10 x 2	Pie Plate, Nonstick
9½	Tart Pan
12-cup	Bundt Pan
18 x 13 x 1	Half-Sheet Pan

OVEN RACK POSITION DIAGRAM

The diagram opposite illustrates the four rack positions for this convection oven. The bottom position is number 1. The positions will be referenced in the cooking charts and recipes.

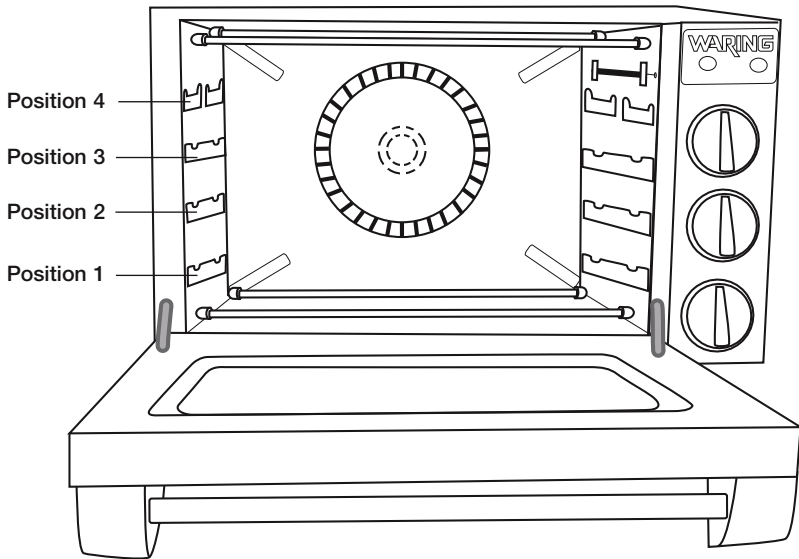

TIPS AND HINTS

- It is important to rotate any item you are baking in the oven to ensure even cooking.
- It is recommended to bake one rack at a time. If you do bake with more than one rack, be sure to rotate both the baking tray and the rack positions halfway through bake time.
- To ensure even flow of air when using baking tray or other utensils, do not slide tray to the back of oven. Leave about 1 to 2 inches of air space around all sides of each pan for even air circulation.
- Make sure the wire racks are in the desired position before you turn on the oven.
- Bake on the shortest time suggested and check for doneness before adding more time. Baked goods are done when a stainless steel knife inserted into the center of the baked item comes out clean.
- See reference charts on pages 23–24 for recommended baking times and temperatures.

- When baking pastry, browning is most successful when you use metallic bakeware as opposed to glass or ceramic.
- Both the convection bake, roast and the rotisserie functions create the finest tastes in meats and poultry with minimal ingredients and simple preparation. One easy rule of thumb to create a quick and easy meal is to match a type of meat, poultry or fish with complementary fresh herbs, a touch of olive oil, and some salt and pepper. Simply chop some garlic and a handful or two of a fresh herb, and mix with some olive oil. Rub on the meat or fish and allow to marinate if time allows (for at least a half hour).

Either way, right before placing item in the oven, sprinkle with salt and pepper.

Some examples of potential flavor combinations are:

Poultry: rosemary, thyme, basil, garlic, lemon

Beef: oregano, rosemary, thyme, mustard, garlic

Lamb: rosemary, garlic

Pork: sage, garlic

Fish: cilantro, basil, citrus

You may not want to use all of the ingredients listed for each category. Experiment – the key is to use ingredients and flavors that appeal to your taste.

BRINING

Brining leaner cuts of meat such as poultry, turkey, and pork in a saltwater solution produces juicier roasts and rotisserie. The difference between brined and non-brined meats is very noticeable. If you have the time it is definitely recommended.

The rule to follow is to use a cup of table salt or 1½ cups kosher salt for every gallon of water.

Or, for smaller cuts of meat, ½ cup kosher salt for every quart of water.

Simply mix salt and water together. Place item to be brined in a non-reactive container or sealable plastic bag large enough to completely immerse the meat. Pour in the brine, cover, and refrigerate.

The amount of time needed to brine depends on how big the roast is. Following is a simple guideline:

Whole chicken	3–8 hours
Chicken parts	1–2 hours
Whole turkey	12–24 hours
Turkey breast	4–6 hours
Game hens	1–2 hours
Pork chops	2–6 hours
Pork tenderloin	2–6 hours
Pork loin	24 hours

It is important to thoroughly rinse and dry the meat once you remove it from the brine, so when it roasts it will be juicy, not salty.

FINISHED COOKING TEMPERATURES

Always check internal temperature using an instant-read thermometer.

Rare	Bright red center, lighter pink to outside	130°F
Medium	Light pink center, brown to outside	160°F
Well Done	Brown consistently throughout	170°F+

Beef/Lamb

The USDA recommends cooking all ground beef to at least **Medium (160°F) doneness**, or until centers are no longer pink.

Pork

Always cook until the internal temperature reaches 160°F when tested with an instant-read thermometer.

Poultry

Poultry should be cooked to an internal temperature of 170°F for white meat and 180°F for dark meat.

Ground poultry should be cooked to an internal temperature of 165–170°F.

Turkey breast should be cooked to an internal temperature of 170°F.

Fully cooked ham should reach an internal temperature of 140°F.

Veal

Veal should be cooked to an internal temperature of 140°F.

USE AND CARE

Always allow the oven to cool completely before cleaning.

1. Always unplug the oven from the electrical outlet before cleaning.
2. After the oven cools, use a damp cloth or sponge to clean interior and exterior surfaces.
3. Do not soak the inside of the oven or wash it in running water, as this will cause serious damage to the appliance.
4. Do not use any sharp or hard kitchen utensils on the oven, as this could damage the surface of the appliance.

5. The wire racks, baking tray, rotisserie spit and skewers can be washed in the dishwasher on the top shelf.
6. To clean the glass door, use a glass cleaner or a damp cloth. Wipe dry with a clean cloth.
7. If the oven has not been used for an extended period of time, take care to remove dust and moisture before operating.
8. If there is something wrong with this product, please contact an authorized Waring Service Center for repair, or phone Waring Customer Service at 1-800-492-7464.
9. Should the oven light located in upper back right hand side of the oven become loose during shipping, please follow the steps below to affix or replace light bulb:

Installing and Replacing Oven Light

A. Removing the Oven Light Cover

1. Insert a Phillips-head screwdriver into the slot in the thumb screw that holds the oven light cover in place.
2. Rotate the screwdriver counterclockwise to remove the screw.
3. Remove the oven light cover.

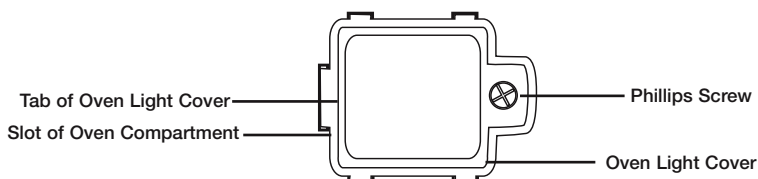

B. Install or Replace the Oven Light

1. Use a 120V/15W, clear appliance light bulb or phone Waring Customer Service at 1-800-492-7464.

C. Replace the Oven Light Cover

1. Insert the tab of the oven light cover into the slot in the side of the oven compartment.
2. Insert the thumb screw into the hole in the oven light cover.
3. Holding the thumb screw, push the oven light cover toward the side of the oven until the thumb screw enters the screw hole.
4. Turn the thumb screw clockwise by hand until the threads start to engage.
5. Insert the screwdriver in the slot of the thumb screw.
6. Tighten the thumb screw by turning the screwdriver clockwise.

REFERENCE CHARTS

Please keep in mind that the following charts are merely a guideline for baking, roasting, broiling and rotisserie. There are many variables to consider for every individual recipe. Temperatures and baking times may vary accordingly. Our advice is to review your recipe first and then refer to the specific charts. All temperature given are Fahrenheit.

SUGGESTED BROILING TIMES

Food	Shelf Position	Weight or Thickness	Approximate Broiling Time (Min.)
Beef Sirloin	4	1½ inches	10-12
Hamburger	4	1 inch	10-15
Pork Chop	4	¾ inch	15
Fish Fillets	4	½ inch	8-15
Boneless Chicken	4	3-4 lbs.	12-15
Lamb Chops	4	1 lb.	8-10

SUGGESTED ROTISSERIE TIMES

Food	Weight (lbs.)	Oven Temp (°F)	Rotisserie Time (Min.)
Beef, Boneless Eye Round	4-6	375-400°	45-75
Chicken	3-7	375-425°	45-90
2 Chickens	3 each	375-425°	75-80
Cornish Hens	1-2	375-425°	35-45
Lamb, Boneless	5	400°	40-50
Pork, Roast	3-4	400°	50-60

CONVECTION/CONVENTIONAL COOKING TIMES

Food	Weight (lbs.)	Recommended Setting	Rack Position	Oven Temp (°F)	Time (min.)
BEEF					
Rib Eye Roast	6-8	Conv Bake, Roast or Rotisserie	2	325°	15-18 /lb.
Meat Loaf - Med.	1½	Convection Bake	2	350°	60-65
LAMB					
Lamb Leg	3-7	Conv Bake, Roast or Rotisserie	2	325°	15-18 /lb.
Rack	1½	Convection Bake or Roast	2	375°	15-18 /lb.
PORK					
Pork Loin	3-5	Convection Bake or Roast	2	375°	25-30 /lb.
Ribs	3-8	Bake	1, 2 or 3	350°	2 hours
Ham, fully cooked	5-12	Convection Bake	1 or 2	325°	18 /lb.
POULTRY					
Chicken, whole	3-8	Conv Bake, Roast or Rotisserie	2	375-400°	45-75
Turkey, stuffed	12-18	Convection Bake	1	350°	18-20 /lb.
Turkey, brined	12-18	Convection Bake	1	350°	18-20 /lb.
Boneless Stuffed Turkey Breast	3-5	Convection Bake	2	350°	20 /lb.
Cornish Hens	1-2	Convection Bake or Rotisserie	2	375°	18-20 /lb.
Duck	4-6	Convection Bake or Roast	2	375-400°	18 /lb.
VEAL					
Rack	4	Convection Bake	1	375°	75-90
Roast	2½-5	Convection Bake or Rotisserie	2	325/375°	75-120

CONVECTION/CONVENTIONAL COOKING TIMES

Food	Pan Size	Recommended Setting	Oven Temp (°F)	Time (min.)
BREADS				
Yeast Loaf	Loaf Pan	Convection Bake	375-400°	35-40
Yeast Rolls	Baking Tray	Convection Bake	375-400°	20-25
Focaccia	Baking Tray	Convection Bake	400°	20-25
Pizza Dough	Baking Tray	Convection Bake	400°	12 (dough)
Artisan	Baking Tray	Convection Bake	375-400°	20-40
QUICK BREADS				
Biscotti	Baking Tray	Convection Bake	325°	45
Corn	Muffin Pan	Convection Bake	375°	20-25
Muffins	Muffin Pan	Convection Bake	375°	20-25
CAKES				
Angel Food	Tube Pan	Convection Bake	350°	40
Bundt	Tube Pan	Convection Bake	350°	45-55
Cupcakes	Muffin Pan	Convection Bake	325°	20-30
Layer, Sheet	13" x 9"	Convection Bake	350°	30-40
Layer, Two	9" Round	Convection Bake	350°	35-45
COOKIES				
Brownies	13" x 9"	Convection Bake	350°	30-45
Sugar	½ Sheet	Convection Bake	375-400°	8-10
Chocolate Chip	½ Sheet	Convection Bake	375°	10-12
PASTRY				
Cream Puffs	Cookie Sheet	Bake	400°	30-35
PIES				
Crust, Unfilled	9" Round	Convection Bake	400°	25-30
Crust, Filled	9" Round	Convection Bake	350°	50-60
Apple	9" Round	Convection Bake	350°	60-75
Pumpkin	9" Round	Bake	350°	60-65
Pecan	9" Round	Bake	350°	60-75
Key Lime	9" Round	Bake	350°	15-20
ENTREES				
Lasagna, Frozen	Baking Tray	Convection Bake	375°	55-60
Pot Pie	Baking Tray	Convection Bake	375°	30-35
Quiche	9" Tart Shell	Convection Bake	350°	25
Pizza, 12"	Baking Tray	Convection Bake	450°	20-25
VEGETABLES				
Baked Potato	On Rack	Convection Bake	400°	50
French Fries	Baking Tray	Convection Bake	375°	15-20
Roasted Vegetables	Baking Tray	Convection Bake	400°	35-40

RECIPES

Italian-Style Meatloaf Wrapped in Bacon	26
Rosemary Chicken With Garlic.	27
Hoisin-Glazed Cornish Hens	28
Rotisserie Pork Loin With Sage-Garlic Rub.	29
Rotisserie Garlic Eye Round.	30
Cod With Ginger Lime Crust.	32
Salmon With Honey Soy Glaze.	33
Braised Short Ribs	33
Roasted Root Vegetables	35
Broccoli and Cheddar Twice-Baked Potatoes	36
Cheddar Corn Soufflé	37
Spring Vegetable Quiche	39
French Bread/Rolls	41
Honey Wheat Rolls	43
Foccacia Romana	44
Blueberry Cinnamon Pecan Muffins.	45
Banana Walnut Loaf Cake	46
Lemon Meringue Pie.	47
Pecan Pie.	49
Pâte Brisée/Pie Pastry	50
Mile-High Apple Pie	51
Chocolate Soufflé Cake	53

ITALIAN-STYLE MEATLOAF WRAPPED IN BACON

Serves 8–10

- 2** pounds meatloaf mix, equal amounts of ground beef, pork, and veal
- 1** tablespoon finely chopped garlic
- ½** cup chopped fresh parsley
- 2** cups seasoned bread crumbs
- 1** cup marinara sauce
- 2** eggs
- ¾** cup shredded mozzarella
- ¾** cup grated Parmigiano–Reggiano
- ¼** teaspoon crushed red pepper
- 4** strips center cut bacon

Preheat oven to 375°F on convection bake, rack set in position 1 (bottom position).

With clean hands, mix all ingredients except the bacon in a mixing bowl until well incorporated. Press mixture into 1½-pound loaf pan. Lay strips of bacon lengthwise along top of loaf, tucking ends between inside of pan and the meat.

Place meatloaf on the bottom rack, position 1 and bake for 60 to 70 minutes, until loaf is cooked through and meat thermometer registers 165–170°F.

Nutritional information per one serving:
Calories 502 (56% from fat) • carb. 26g • pro. 29g • fat 31g
sat. fat 13g • chol. 139mg • sod. 1266mg • calc. 195mg

ROSEMARY CHICKEN WITH GARLIC

Serves 2–3

- 1 3–3½ pound chicken, rinsed and patted dry**
- 1 lemon, cut in half (for roasting chicken, not rotisserie)**
- 2 sprigs rosemary**
- 2 garlic cloves, smashed**
- ¾ teaspoon kosher salt**
- ½ teaspoon crushed black pepper**
- 1 tablespoon olive oil**
- butcher's twine if using rotisserie function**

If roasting chicken, preheat oven to 375°F on convection bake.

Squeeze lemon all over outside and inside chicken. Stuff the chicken with the lemon halves, rosemary sprigs, garlic cloves, and pinch of the salt and pepper. Sprinkle the rest of the salt and pepper all over the skin of the chicken and then rub the olive oil all over the skin.

To roast: Place chicken on baking sheet lined with foil. Roast for 45 minutes to an hour in rack position 1 or 2 (bottom or middle rack position) until the juices run clear when the thigh is pierced.

If using the rotisserie: Prepare chicken as above, omitting the lemon. Truss the chicken well. Insert the rotisserie spit through the chicken, securing the rotisserie skewers with the fixing screws so that the chicken is stabilized. Secure the rotisserie spit in the oven into the spit support and socket. Turn oven to 400°F and turn to rotisserie on the function dial. Roast for about 45 minutes to an hour, so that when the thigh is pierced the juices run clear. To ensure even, crispy skin, carefully baste the

chicken the last 15 minutes of cooking time using the juices from the drip pan.

Nutritional information per serving:
Calories 603 (64% from fat) • carb. 5g • pro. 52g • fat 46g
sat. fat 13g • chol. 207mg • sod. 529mg • calc. 68mg

HOISIN-GLAZED CORNISH HENS

Serves 2

- ½ cup hoisin sauce**
- 2 tablespoons honey**
- 2 tablespoons soy sauce**
- 1 tablespoon finely chopped fresh ginger**
- 2 garlic cloves, crushed**
- 2 Cornish game hens, 1–1¼ pounds each, rinsed and patted dry**

In a mixing bowl stir together the hoisin sauce, honey, soy, ginger and garlic.

Place the hens in a sealable plastic bag. Pour the marinade into the bag and refrigerate for at least an hour up to overnight.

When ready to cook, remove hens from bag and place on a clean work surface. Truss both hens well as you would a chicken. Insert the rotisserie spit through both hens, securing the rotisserie skewers with the fixing screws so that they are stabilized. Secure the rotisserie spit in the oven into the spit support and socket. Turn oven to 400°F and turn to rotisserie on the function dial. Roast for 35 to 40 minutes. For the last 5 minutes of cooking time, turn oven function to regular bake when the breasts are facing up in order to crisp the skin.

Carefully remove rotisserie spit using the hand grip.

Serve with steamed rice.

*The hoisin marinade is very versatile; brush it on salmon fillets and broil for about 15 minutes for an easy meal.

Nutritional information per serving:
Calories 594 (30% from fat) • carb. 49g • pro. 116g • fat 32g
sat. fat 9g • chol. 357mg • sod. 742mg • calc. 134mg

ROTISSERIE PORK LOIN WITH SAGE-GARLIC RUB

Serves 4–6

- 2** **garlic cloves**
- ½** **cup fresh sage leaves**
- ½** **teaspoon kosher salt**
- ½** **teaspoon fresh ground pepper**
- ¼** **cup olive oil**
- 1** **pork loin, 2½–3 pounds***

Place the garlic cloves in the work bowl of a food processor. Process until finely chopped. Add sage leaves, salt and pepper and process. With the machine running, add the olive oil so that a wet paste forms. Reserve.

Place pork loin on a work surface and rub the oil and herbs all over the pork. Place in a sealable plastic bag with all of the marinade. Keep in refrigerator for an hour.

Return pork to work surface. Tie butcher's twine around the loin every 2 inches along the length of the loin. Place the rotisserie spit through the center of the pork loin. Set the rotisserie skewers and fixing screws so that the loin is secured firmly in place.

Secure the rotisserie spit in the oven into the spit support

and socket. Turn the oven to 400°F and turn to the rotisserie setting. Cook for about 45 to 55 minutes, checking after 45 minutes with meat thermometer to achieve desired doneness. Pork is considered medium at 160°F.

Carefully remove rotisserie spit using handgrip. Allow pork to rest 5 to 10 minutes and serve.

* If you brine the pork (which is recommended), refer to brining instructions on page 18. Rinse it well and omit the salt from the rub recipe.

Nutritional information per serving:

Calories 456 (66% from fat) • carb. 0g • pro. 37g • fat 33g
sat. fat 9g • chol. 119mg • sod. 209mg • calc. 42mg

ROTISSERIE GARLIC EYE ROUND

Easy enough for a weeknight dinner – the leftovers are fantastic in a sandwich with horseradish sauce, tomatoes, and arugula.

Serves 6–8

- 1 eye round roast, 4 pounds**
- 3 garlic cloves, cut into thin slices**
- 2 tablespoons Dijon mustard**
- 2 tablespoons extra virgin olive oil**
- 1 teaspoon kosher salt**
- ½ teaspoon coarse black pepper**

Trim eye round of any excess fat.

With a paring knife, make slits all over the surface of the roast.

Push the slices of garlic into the slits. Rub the roast with the mustard, olive oil, salt, and pepper. Although it is not

necessary, you may tie the roast evenly with butcher's twine to ensure even cooking. Place the rotisserie spit through the center of the roast. Set the rotisserie skewers and fixing screws so that the roast is secured firmly in place.

Secure the rotisserie spit in the oven into the spit support and socket. Turn the oven to 400°F and turn to the rotisserie setting. Cook for about 50 to 60 minutes, checking after 45 minutes with meat thermometer to achieve desired doneness.

Carefully remove rotisserie spit from oven using the handgrip. Allow meat to rest 5 to 10 minutes before serving.

Nutritional information per serving:

Calories 408 (58% from fat) • carb. 1g • pro. 40g • fat 26g
sat. fat 10g • chol. 117mg • sod. 356mg • calc. 13mg

Variation: It is possible to prepare a boneless leg of lamb in the same fashion:

Add 1 tablespoon of chopped fresh rosemary to rub all over the lamb. The mustard can be an optional ingredient. It is, however, essential to tie the leg together with butcher's twine before securing the rotisserie spit and skewers.

Once rotisserie spit is secured in the oven, set oven temperature to 400°F. Cook 12 to 15 minutes per pound for rare, 20 minutes per pound for medium. Be sure to check internal meat temperature with a meat thermometer.

COD WITH GINGER LIME CRUST

Serves 4

- 1 cup unsalted butter**
- 4 cups panko breadcrumbs**
- ¼ cup chopped fresh ginger**
- 1 tablespoon lime zest (about 1 lime)**
- 1½ teaspoons kosher salt**
- 2 pounds cod, or any firm white fish**

Preheat oven to 450°F set to the broil function.

Place the butter in the work bowl of a food processor fitted with a metal blade. Process for 5 to 10 seconds until butter has softened. Add breadcrumbs, ginger, lime zest, and salt and process until mixture comes together. Reserve.

Cut cod into even portions. Press together the breadcrumb mixture to create a thick and full covering for the top surface of the fish.

Place the cod with breadcrumb covering on a foil-lined baking sheet. Place in the oven in position 4 (top rack position), with door ajar about 2 inches. Broil for 8 to 10 minutes, until the topping is golden and the fish flakes easily with a fork.

Nutritional information per serving:

Calories 497 (47% from fat) • carb. 38g • pro. 27g • fat 26g
sat. fat 15g • chol. 113mg • sod. 767mg • calc. 89mg • fiber 2g

SALMON WITH HONEY SOY GLAZE

Serves 4

- ¼ cup honey or maple syrup**
- ¼ cup soy sauce**
- 2 pounds boneless salmon steaks (4 steaks)**

Preheat oven to 500°F and set to the broil function.

In a small saucepan boil the soy and honey until it reduces to a very thick consistency, about 3 minutes.

Place salmon on the baking tray lined with foil. Brush the glaze all over the top and bottom of the salmon. Place baking tray in position 4. Broil for about 8 minutes with door slightly ajar, about 2 inches. Remove and brush more glaze over the salmon, reserving about ¼ cup. Broil another 8 minutes, pour the remaining glaze over the fish and serve.

Nutritional information per serving:

Calories 411 (17% from fat) • carb. 38g • pro. 47g • fat 8g
sat. fat 1g • chol. 118mg • sod. 2211mg • calc. 38mg

BRAISED SHORT RIBS

Serves 4–6

- 2 teaspoons extra virgin olive oil**
- 3 pounds short ribs**
salt and pepper
- 4 ounces onion, peeled and chopped**
- 2 garlic cloves**
- 2 ounces carrot, peeled and chopped**
- 2 sprigs thyme**
- 2 tablespoons balsamic vinegar**
- 2 cups dry red wine**
- 1 tablespoon tomato paste**
- 1 cup plus stock (beef or chicken) or water**

Heat olive oil over medium/medium-high heat in a 3-quart casserole. Place the ribs on a plate and liberally salt and pepper them on both sides.

In batches, brown the ribs well on all sides. Reserve browned ribs on plate. Pour off all but 1 tablespoon of oil from casserole.

Once the ribs are browned preheat oven to 300°F with the function set to regular bake, rack in position 2.

Add onion, garlic, and carrots to casserole and brown. As the vegetables brown, scrape the residue on the bottom of the casserole with a wooden spoon to mix in with the vegetables. Add the sprigs of thyme and stir. Once vegetables are well browned and soft, add the vinegar. It will reduce immediately; when it does, add the red wine and simmer for about 5 minutes until the wine has been reduced by half. Stir in the tomato paste and place the ribs back into the casserole. Stand the ribs up so that the rib is actually sticking up in the air. Add enough stock for the liquid to come half way up the sides of the ribs.

Cover casserole and place in oven. Check every half hour to make sure the liquid is merely simmering. If the liquid is boiling rapidly, reduce the temperature of the oven. If necessary add more stock. After one hour, turn the ribs in the liquid with a pair of tongs. Cover and return to oven until the meat is falling off the bone and very tender – about another 1 to 1½ hours.

Remove ribs from liquid and reserve. Place casserole on stove. Skim fat well and reduce the liquid so that it thickens to a sauce consistency. Return ribs to sauce to warm and serve.

It is also possible to cool ribs in their liquid and refrigerate to reheat and serve the following day (the flavors will just intensify and get better over night).

Nutritional information per serving:

Calories 556 (41% from fat) • carb. 18g • pro. 48g • fat 25g
sat. fat 8g • chol. 146mg • sod. 3676mg • calc. 43mg • fiber 1g

ROASTED ROOT VEGETABLES

Makes 8 servings

- 1 pound Yukon Gold or fingerling potatoes, cut into ½-inch rounds**
- 1 pound yam, peeled, cut in half lengthwise, sliced into ½-inch half moons**
- 1 cup parsnips, peeled and cut into ½" slices**
- 1 cup peeled baby carrots**
- 4 garlic cloves, smashed**
- ¼ cup extra virgin olive oil**
- 1 teaspoon kosher salt**
- ½ teaspoon coarsely ground black pepper**

Preheat oven to 450°F on roast or convection bake, racks in position 1 and 3.

In a large mixing bowl toss all ingredients together well.

Divide ingredients between 2 half-sheet trays lined with aluminum foil.

Place in oven in set rack positions. After 20 minutes remove racks to lightly toss vegetables on tray and return trays to oven, rotating both trays and racks. Bake for an additional 20 to 25 minutes, toss one more time and bake until all vegetables are evenly browned, about 5 minutes.

Nutritional information per serving:

Calories 207 (30% from fat) • carb. 34g • pro. 3g • fat 7g
sat. fat 1g • chol. 0mg • sod. 189mg • calc. 33mg • fiber 6g

Variation: Add 2 teaspoons of your favorite chopped herb, such as rosemary or thyme.

Another nice addition to this vegetable mix would be a ½ cup of Brussels sprouts cut in half.

BROCCOLI AND CHEDDAR TWICE-BAKED POTATOES

Makes 4 servings

- 4 russet potatoes, about 10 ounces each**
- 1 tablespoon unsalted butter**
- 1 teaspoon extra virgin olive oil**
- 2 green onions, trimmed and chopped**
- 1 broccoli crown, about 6 ounces, trimmed and chopped into ½-inch pieces**
- ¾ cup milk (may use whole milk, reduced fat, or fat-free)**
- 4 ounces sharp Cheddar, grated**
- ½ teaspoon kosher salt**
- ¼ teaspoon freshly ground black pepper**

Preheat oven to 400°F on convection bake with rack in position 2 (middle position).

Pierce each potato with a fork in several places. Place directly on the rack and bake until potatoes are soft, about 50 minutes.

While the potatoes are baking, melt butter in olive oil in a 10-inch skillet. Add green onions and broccoli. Stir to coat the vegetables and then cover the skillet to steam them for 4 to 5 minutes so that they are tender but still crisp. Uncover, remove from heat and reserve.

When potatoes are cool enough to handle, cut off top third of the potatoes and scoop out flesh, leaving ¼-inch thick shell. Reserve flesh and skins; discard tops or reserve for another use.

Using an electric mixer or hand-held potato masher, mash the potatoes. Add milk, shredded cheese, salt, and pepper. Mash until thoroughly combined. Add the cooled vegetables and stir by hand to combine. Generously fill the reserved potato shells with the potato/broccoli

mixture. At this point you can bake them immediately or refrigerate them until ready to bake (overnight).

Turn oven to 375°F on convection bake.

Arrange potatoes on foil-lined (sprayed with cooking spray) baking tray only. NOTE: No other parts of the oven may be covered with metal foil. Bake in position 1 (bottom rack position) uncovered until tops are golden brown and the potatoes are warmed through, 25 to 30 minutes. If potatoes are cold from the refrigerator, add 5 minutes to baking time.

Remove from oven and serve hot.

Nutritional information per serving:

Calories 369 (25% from fat) • carb. 54g • pro. 17g • fat 10g
sat. fat 4g • chol. 31mg • sod. 498mg

CHEDDAR CORN SOUFFLÉ

Makes one 8-cup soufflé

- 5** **tablespoons unsalted butter, plus extra for soufflé dish**
- 5** **eggs, separated in two mixing bowls**
- 1½** **cups corn (3 ears with husks; see Note)**
- 1½** **cups whole milk**
- ½** **cup unbleached, all-purpose flour plus extra for dusting soufflé dish**
- 2** **cups grated sharp Cheddar**
- 1** **teaspoon kosher salt**
- ½** **teaspoon fresh ground pepper**
dash of hot sauce

Preheat oven to 350°F on convection bake with baking tray in position 1 (the bottom position).

Butter an 8-cup soufflé dish well.

Beat yolks and reserve.

In a blender or food processor, purée 1½ cups of corn with the milk; reserve.

Melt butter in a saucepan. Add flour and stir with a wooden spoon until smooth. Cook over medium heat for 2 minutes, stirring occasionally. Pour the milk/corn purée into saucepan as you whisk simultaneously. Whisk until the mixture is a smooth consistency. Continue to heat slowly, whisking occasionally, until the mixture becomes smooth and thick, about 3 to 5 minutes. Stir in Cheddar until melted and incorporated. Stir in remaining corn, salt, pepper, and hot sauce. Remove from heat and reserve.

Spoon a small amount of the cheese mixture into the yolks, whisking at the same time. Continue adding all of the cheese slowly to the yolks, whisking the whole time. Reserve.

With an electric mixer, beat the egg whites until peaks form that are stiff but not dry, about 3 minutes.

Gently fold the whites into the yolk-cheese mixture in three increments, using a large rubber spatula, so that the two are well incorporated.

Pour mixture into prepared soufflé dish and bake until the soufflé is golden and puffed over the rim of the dish, approximately 35 to 40 minutes.

Serve immediately.

Nutritional information per serving:

Calories 257 (59% from fat) • carb. 16g • pro. 11g • fat 17g
sat. fat 9g • chol. 173mg • sod. 323mg • calc. 176mg

NOTE: A great way to prepare the corn for this dish is to roast it.

Preheat oven to 450°F on convection oven/roast. On the baking sheet place the 3 ears of corn with about ¼ cup of water and place in the bottom rack position (position 1). Roast for about 20 to 25 minutes until you can smell the corn and the husks are brown. Remove from oven and allow corn to cool completely before you remove the husks.

SPRING VEGETABLE QUICHE

Makes one 9-inch quiche

- 4** ounces asparagus, tough ends removed
- 1½** teaspoons extra virgin olive oil
- ¼** teaspoon kosher salt
- ½** recipe Pâte Brisée, page 50
- 1** shallot, thinly sliced
(approximately 2 tablespoons)
- 1-2** ounces prosciutto, sliced into small dice
- 2** tablespoons fresh shelled or frozen peas
- 2** tablespoons fresh basil, chopped
- ½** cup half-and-half or whole milk
- ½** cup heavy cream
- 1** egg
- 1** egg yolk
- ¼** cup grated Parmigiano-Reggiano

Preheat oven to 425°F on convection bake.

Line the baking tray with aluminum foil. Toss the asparagus on the tray with 1 tablespoon of olive oil and ¼ teaspoon of kosher salt. Roast on rack 2 (middle rack position) for 5 to 10 minutes, depending on the thickness of the asparagus. Remove asparagus when it has softened and browned slightly but still crisp-tender. Once cool, cut asparagus into ½-inch pieces. Reserve.

While asparagus is in the oven, roll the pâte brisée to fill

a 9-inch tart pan, form the edges and return it to the refrigerator to rest for at least a half-hour.

Turn oven down to 400°F on convection bake, in rack position 1 (bottom position). Allow at least 10 minutes for oven to come down in temperature.

Line the tart shell with parchment and dried beans or pie weights. “Blind bake”: bake the pastry for about 20 minutes, until it appears a light golden. Remove pastry shell from oven, remove the pie weights and reserve them separately.

Turn oven down to 350°F on convection bake, with same rack position.

While tart shell is baking, heat the remaining half tablespoon of olive oil in a small skillet over medium heat.

Sauté the shallot until soft, about 5 minutes. Turn heat to low and add prosciutto and peas. Stir until peas soften, about 2 minutes. Turn heat off and stir in basil.

In a mixing bowl whisk together the half-and-half, cream, egg and egg yolk.

Scatter the vegetable mixture evenly along the bottom of the baked tart shell. Sprinkle the parmesan on top of the vegetables. Pour the custard into the shell just up to the edge of the crust.

Place quiche on the bottom rack. Bake for about 25 minutes, until the custard becomes set, golden and puffy.

Nutritional information per serving:

Calories 262 (68% from fat) • carb. 15g • pro. 6g • fat 20g
sat. fat 12g • chol. 113mg • sod. 257mg • calc. 44mg • fiber 1g

FRENCH BREAD/ROLLS

This very simple and versatile bread dough makes delicious homemade bread every time. This recipe also doubles easily.

Makes one 1½-pound loaf, 2 small 8-inch baguettes, or twelve 2-ounce rolls

- 1¼ teaspoons active dry yeast**
- 1 cup warm water (110°F)**
- pinch granulated sugar**
- 1 pound unbleached, all-purpose flour**
- ½ teaspoon kosher salt**
- 1 large egg**
- 1 tablespoons water**
- cooking spray**

Proof yeast in warm water and sugar and leave to foam, about 5 minutes.

Place flour and salt in the work bowl of a food processor fitted with a dough blade. Process for 5 seconds.

With the machine running, pour the water and yeast mixture through the feed tube. If the dough still seems dry, add ¼ cup of water at a time, watching the dough after each addition. The dough is of adequate consistency once a ball forms. Keep machine running for about 2 minutes to knead the dough. Turn the dough out into a plastic, sealable bag and either leave in a warm place to rise or refrigerate to use the next day. If leaving out to rise, allow an hour for dough to rise, punch down and allow to rise again for another hour before baking. If using directly from the refrigerator, allow to come to room temperature, punch down and allow to rise for another half-hour.

To bake:

Preheat oven to 400°F on convection bake.

In a small bowl whisk together egg and water.

For loaf:

Lightly spray a 1½-pound loaf pan. Roll dough on a floured work surface into a short, fat cylinder. Place it in prepared pan and loosely cover it with plastic for the final rise. Once loaf rises again after a half hour, make 3 slashes diagonally with a serrated knife on the top of loaf and brush with egg wash. Bake on rack position 1 for about 35 to 40 minutes, rotating pan halfway through bake time, until it is a deep golden on top and sounds hollow when tapped on the bottom.

For baguettes:

Line baking tray with parchment. Divide dough in half and roll each into a long thin cylinder on a floured work surface. Place on tray, cover loosely with plastic and allow to rise for a half hour. Bake in position 1 for 35 to 40 minutes, rotating tray halfway through bake time, until bread is a deep golden brown on top and sounds hollow when tapped on the bottom.

For rolls:

Divide dough into twelve 2-ounce pieces. Roll each on a floured work surface with your hands to form a ball. Place 6 at a time on a parchment-lined baking tray and cover loosely with plastic to rise for a half-hour. Slash the tops of the rolls with a serrated knife and brush with egg wash. Bake in position 2 (middle rack) for 20 minutes, rotating tray halfway through bake time, until rolls are a deep golden brown.

Nutritional information per serving:

Calories 142 (4% from fat) • carb. 29g • pro. 4g • fat 1g
sat. fat 0g • chol. 9mg • sod. 60mg • calc. 7mg • fiber 1g

Variation: This bread makes fantastic bruschetta.

Simply slice either baked loaf into ¾-inch slices, place on the baking tray lined with foil and drizzle with extra virgin olive oil. Place under the preheated broiler for 3 minutes

per side. Once removed from oven, rub a cut garlic clove on each slice. Serve alone or with a topping or spread.

HONEY WHEAT ROLLS

Makes 16 rolls

- 6 ounces evaporated skim milk**
- 1 package active dry yeast**
- 1½ tablespoons honey**
- 1 large egg, beaten**
- 2 cups unbleached, all-purpose flour**
- ¾ cup whole wheat flour**
- 4 ounces unsalted butter, cut into 1-inch pieces**
- 1 teaspoon salt**
- 1 large egg**
- 1 tablespoon water**
- cooking spray**

In a small saucepan over medium-low heat, warm the milk to 110°F and remove from heat. Dissolve yeast and honey in milk; let sit until foamy, about 3 to 5 minutes. Stir in the beaten egg and reserve.

In a food processor fitted with a metal blade, process both flours, butter and salt until combined, about 15 to 20 seconds. With the machine running, add the yeast mixture in a steady stream through the small feed tube, as fast as the flour can absorb it. After the dough forms a ball, process for about 60 seconds to knead the dough. Place dough in a sealable plastic bag. Squeeze out the air and seal, allowing space for the dough to rise. Leave the dough to rise in a warm place until it has doubled in size, about 1 hour. Place dough on a floured surface and punch down; let rest for 10 minutes. Coat a 9-inch round baking pan with cooking spray. Divide the dough

into 16 equal pieces and shape each into a ball. Arrange, just touching, in prepared pan. Cover loosely with plastic sprayed with cooking spray. Allow to rise 30 minutes in a warm place.

Fifteen minutes prior to baking, preheat oven to 350°F on convection bake with rack in position 2 (middle rack position).

In a small bowl whisk together egg and water and brush the tops of the rolls. Bake until golden brown, approximately 30 minutes. Turn out onto cooling rack.

Nutritional information per serving:
Calories 140 (42% from fat) • carb. 18g • pro. 4g • fat 7g
sat. fat 0g • chol. 33mg • sod. 163mg • fiber 1g

FOCACCIA ROMANA

This recipe makes a great canvas for any type of topping.

Makes 18 servings

- 1 package active dry yeast**
- 1/8 teaspoon granulated sugar**
- 1/3 cup warm water (110°F)**
- 4 cups unbleached, all-purpose flour**
- 3 teaspoons kosher salt, divided**
- 1 cup cold water**
- 4 tablespoons extra virgin olive oil, divided**
- cooking spray**

Stir yeast and sugar into warm water in a small bowl; let stand until foamy, about 3 to 5 minutes. Place flour and 1 teaspoon of salt in the work bowl of a food processor fitted with a dough blade; process to combine, about 20 seconds. Add cold water and 2 tablespoons of oil to the yeast mixture.

With machine running, pour liquid through feed tube in a steady stream as fast as the flour absorbs it, about 30 seconds. Once dough pulls away from sides of the work bowl keep the machine running for about 1 minute to knead.

Place dough in a lightly floured, sealable plastic bag. Let rise in a warm place until doubled in size, about 45 minutes.

Turn the dough out onto a floured work surface. Roll into a long rectangular shape and then press into a lightly sprayed baking sheet, stretching the ends of the dough to meet the edges of the baking tray. Make indentations in the dough with your fingers over the entire surface area. Brush the dough with the remaining olive oil and sprinkle with the remaining kosher salt. Cover loosely with plastic wrap and let rise until puffy, about 20 minutes.

Preheat oven to 400°F on convection bake.

Bake until golden and crisp, about 20 to 25 minutes. Let cool slightly on wire rack. Serve warm.

Nutritional information per serving:
Calories 127 (23% from fat) • carb. 21g • pro. 3g • fat 3g
sat. fat 0g • chol. 0mg • sod. 392mg • fiber 1g

BLUEBERRY CINNAMON PECAN MUFFINS

These delicious muffins are simple to prepare and bake.

Makes 12 muffins

- 1 large egg**
- ½ cup buttermilk**
- ¼ cup vegetable oil**
- 1 teaspoon pure vanilla extract**

½ cup granulated sugar
1½ cups unbleached, all-purpose flour
2 teaspoons baking powder
½ teaspoon ground cinnamon
½ cup chopped, toasted pecans
½ cup blueberries, fresh or frozen
(thawing not necessary)
cooking spray

Preheat oven to 350°F on convection bake with rack in position 1 (bottom position).

Spray standard size (2½ inch x 1¼ inch) muffin tin with nonstick cooking spray.

In a large mixing bowl, mix together the egg, buttermilk, vegetable oil, and vanilla. Stir in sugar and then the remaining dry ingredients. Carefully stir in pecans and blueberries (berries will bleed if you overwork them).

Scoop batter evenly into muffin tin. Bake for about 20 to 25 minutes, until muffins are golden and a cake tester comes out clean.

Nutritional information per serving:

Calories 206 (48% from fat) • carb. 24g • pro. 3g • fat 11g
sat. fat 1g • chol. 18mg • sod. 153mg • calc. 21mg • fiber 1g

BANANA WALNUT LOAF CAKE

Makes one 1½-pound loaf, 12–14 slices

2 cups unbleached, all-purpose flour
½ teaspoon baking powder
¾ teaspoon baking soda
½ teaspoon salt
½ cup unsalted butter, room temperature
1 cup granulated sugar
2 eggs

- 1½ teaspoons pure vanilla extract**
- ¼ cup buttermilk**
- 1½ cups mashed banana**
(approximately 2 ripe, medium bananas)
- ½ cup plus 2 tablespoons chopped walnuts**

Preheat oven to 325°F on convection bake with rack in position 1, the lowest position.

Spray a 1½-pound loaf pan with nonstick cooking spray.

Sift together flour, baking powder, baking soda and salt and reserve.

Using an electric mixer or food processor, cream together the butter and sugar.

Add eggs one at a time until incorporated. Add vanilla and buttermilk and mix until smooth.

Gradually add the dry ingredients and mix until just incorporated. Finally, mix in both the mashed banana and walnuts until incorporated. Scrape the sides and bottom of bowl and pour out into the prepared pan.

Bake for approximately 60 to 65 minutes, until top is golden and a cake tester comes out clean.

Nutritional information per slice:

Calories 324 (44% from fat) • carb. 42g • pro. 5g • fat 16g
sat. fat 6g • chol. 56mg • sod. 195mg • calc. 28mg • fiber 2g

LEMON MERINGUE PIE

Serves 12

Shortbread Crust

- 12 tablespoons unsalted butter, room temperature**
- ½ cup confectioners' sugar**
- 2 tablespoons granulated sugar**

- 1½ cups unbleached, all-purpose flour**
- ¼ teaspoon table salt**
- ½ teaspoon pure vanilla extract**
- 2 teaspoons lemon zest**

Filling

- 4 large eggs**
- 1¼ cups granulated sugar**
- 1 heaping tablespoon lemon zest (approximately 2 lemons)**
- ¾ cup lemon juice (approximately 3–4 lemons)**

Meringue

- 6 large egg whites**
- 1 cup granulated sugar**

Crust

Preheat oven to 325°F on convection bake with rack in position 2 (bottom position).

Place softened butter in a large mixing bowl. With an electric mixer, cream the butter until very soft. Add both sugars and mix until well creamed. Add the flour and salt, mixing until just incorporated. Add vanilla and zest and mix.

Press shortbread evenly into 9-inch pie plate, covering the bottom and going up to the edge of the pie plate. Bake for 20 to 25 minutes until the crust is a light golden.

Keep the oven on 350°F, but turn to regular bake.

While the crust is baking, prepare the filling. Whisk the eggs together in a bowl with the 1¼ cup sugar until light and frothy. Whisk in lemon zest and juice.

Place the egg whites in a separate mixing bowl and reserve.

Pour filling into the warm shortbread crust. Bake for 20 minutes until the top is set but the middle still has movement.

Once the filling is set, remove from oven; reduce oven to 325°F on regular bake. Start beating the egg whites with an electric mixer. Once the whites are frothy pour the cup of sugar into the bowl with the mixer running. Beat whites until peaks form that are stiff but not dry.

Pour the meringue on the top of the pie, covering the entire surface of the pie including the crust. Bake until the meringue is golden brown, about 20 minutes.

Allow to cool completely before serving.

Nutritional information per serving:

Calories 367 (32% from fat) • carb. 58g • pro. 6g • fat 13g
sat. fat 8g. chol. 102mg • sod. 100mg • calc. 17mg • fiber 1g

PECAN PIE

Makes 12 servings

Crust

1½ cups unbleached, all-purpose flour
¼ cup granulated sugar
⅛ teaspoon salt
9 tablespoons unsalted butter
1 large egg

Filling

1 cup dark brown sugar, packed
3 large eggs
1 cup dark corn syrup
3 tablespoons unsalted butter, melted
1 teaspoon pure vanilla extract
1 teaspoon ground cinnamon
2 cups pecan halves
1 9-inch deep-dish pie plate
cooking spray

Preheat oven to 325°F on regular bake, rack adjusted to position 2 (bottom rack position).

Place flour, sugar, salt, and butter in the work bowl of a food processor fitted with a metal blade. Process until mixture is like a coarse meal, about 10 seconds.

While machine is running, add egg through feed tube, processing until dough forms a ball, about 30 seconds.

Spray pie plate with nonstick cooking spray. Press the dough into the pan. Be sure to form a solid border of crust onto the edge of the pan. Make sure there are no cracks in the crust. Reserve.

Process the sugar and eggs until smooth, about 30 seconds. Add syrup, butter, vanilla, and cinnamon; process until well mixed, about 45 seconds.

Place pecan halves in pie shell in a single layer; pour filling over pecans to within 1/8-inch of top of crust. Place filled pie pan on rack and bake until crust is browned and filling is set, about 1 hour and 15 minutes.

Nutritional information per serving:

Calories 433 (51% from fat) • carb. 51g • pro. 4g • fat 25g
sat. fat 9g • chol. 51mg • sod. 73mg • calc. 30mg • fiber 2g

PÂTE BRISÉE (PIE PASTRY)

Makes two 9–10 inch pastry crusts

2 cups unbleached, all-purpose flour

1 teaspoon salt

1/2 pound **COLD** unsalted butter

1/2 cup ice water

Place flour and salt in a food processor work bowl fitted with a metal blade. Process for 10 seconds.

Place butter in work bowl and pulse until the mixture resembles coarse meal with the butter visible only in tiny pea-sized bits. With the machine running, pour in water through feed tube. If mixture feels dry and does not come together when you press it together in your hand, add more ice water, a tablespoon at a time, until mixture comes together. Carefully process only until a dough ball forms. Do not overprocess!!

Remove dough from bowl, divide in half, form each half into a disc and wrap in plastic to rest at least a half-hour before rolling.

Nutritional information per serving:

Calories 146 (63% from fat) • carb. 12 g • pro. 1g • fat 10g
sat. fat 6g • chol. 27mg • sod. 100mg • calc. 5mg

Variation: For sweet Pâte Brisée, follow recipe except add 3 tablespoons of granulated sugar to the dry ingredients in the work bowl.

MILE-HIGH APPLE PIE

Serves 12

- 1 recipe sweet Pâte Brisée (page 50)
- 4-6 pounds Granny Smith apples, peeled, cored and cut in half (see Note)
- $\frac{3}{4}$ cup granulated sugar
- $\frac{1}{2}$ cup unbleached, all-purpose flour
- 1 tablespoon lemon zest (approximately 1 lemon)
- 2 tablespoons lemon juice
- 2 teaspoons ground cinnamon
- dash allspice (optional)
- 1 large egg
- 2 tablespoons water
- 1 9-inch pie plate

Preheat oven to 400°F convection bake with rack in position 2 (bottom position).

Divide pâte brisée into 2 pieces, one slightly larger than the other.

On a floured surface, roll out the smaller of the two pieces to fit the pie plate so that the dough hangs over the edge of the plate. Cut the dough if necessary so that the overhang is about 1 inch long. Place in the refrigerator for at least a half hour to rest.

Slice the apple halves thin (about $\frac{1}{8}$ -inch) and place in large mixing bowl. Toss with sugar, flour, lemon zest, juice, cinnamon and allspice.

Carefully fill the pie with the apple slices starting in concentric circles. As you start to gain height with the apples keep layering the slices evenly, lightly pressing on layers as you go. Be sure to fill in gaps with slices until all the apples are used.

Roll out the larger piece of pastry, turning the dough on the floured surface as you roll. You should have an abundant amount to cover the pie. Very carefully, fold the rolled dough in half with the edge of the folded part touching the pie plate. Carefully unfold the dough, lifting as you unfold, to drape the pastry on top of the apples. Press the bottom and top edges together folding over the overhang. Decorate the crust if you wish using your thumb and first finger or a fork. With a knife, cut three $\frac{1}{2}$ -inch vents on the top of the pie.

In a small bowl whisk together the egg and water and brush the egg wash all over the top of the pie.

Bake for 15 minutes. Reduce the temperature to 325°F and bake for an additional hour, or hour and 15 minutes until the crust is nicely browned.

At this point the crust may be done but apples may need additional time to bake. Cover the pie crust with foil and return to the oven for up to an additional half hour, until the juices are bubbling. Serve warm or room temperature.

Nutritional information per serving:

Calories 593 (29% from fat) • carb. 105g • pro. 5g • fat 20g
sat. fat 12g • chol. 50mg • sod. 182mg • calc. 29mg • fiber 7g

NOTE: The amount of apples depends on how deep your pie plate is. For best results with this recipe, use a disposable aluminum pie plate which is rather shallow, holding 4½ pounds of apples.

CHOCOLATE SOUFFLÉ CAKE

This decadent cake is terrific served with whipped cream and/or ice cream and raspberry sauce.

Makes one 10-inch round cake, 16 slices

- 2 tablespoons unsalted butter plus
extra to prepare cake pan**
- 8 ounces bittersweet chocolate**
- 9 large eggs**
- 2 large egg whites**
- 1¼ cups granulated sugar**
- ⅓ cup unbleached, all-purpose flour**

Preheat oven to 350°F on convection bake with the rack placed in position 1, the bottom position.

Cut a circle of parchment paper to line a 10" round cake pan. Butter the bottom and sides of cake pan well. Add enough flour to coat the buttered interior. Tap the pan to remove and discard any excess flour. Place the

parchment circle on the bottom of the pan and butter and flour it as well.

Melt the chocolate and butter together in a double boiler and reserve.

Separate the eggs into two mixing bowls, adding the extra whites to the bowl of whites. Add $\frac{3}{4}$ cup of sugar to the bowl of yolks. Using an electric mixer, mix the yolks and sugar until mixture is pale and thick, about 3 to 4 minutes. Whisk chocolate into yolks and sugar.

Beat the egg whites until soft peaks form, about 3 minutes; add remaining $\frac{1}{2}$ cup of sugar and continue beating until whites are stiff but not dry, about 2 to 3 more minutes. Fold $\frac{3}{4}$ of the whites into the chocolate-yolk mixture in 3 additions using a large rubber spatula. Be sure to scrape the bottom and sides of the bowl as you fold the two together. Sift the flour into the mixture and gently fold in with spatula. Finally, gently fold in the remaining egg whites.

Pour batter into prepared cake pan and bake for about 25 to 30 minutes, until cake has puffed and appears dry but is still soft to the touch.

Turn cake out onto serving plate and remove pan. Sprinkle the top with confectioners' sugar. Serve immediately.

Nutritional information per slice:

Calories 195 (42% from fat) • carb. 25g • pro. 5g • fat 10g
sat. fat 5g • chol. 123mg • sod. 43mg • calc. 22mg • fiber 1g

©2007 Waring Consumer Products
Division of Conair Corporation
150 Milford Road
East Windsor, NJ 08520

www.waringproducts.com

Printed in China

07WR32150

IB-7896