



User's instructions handbook

Imperia

Since 1932, fresh home-made pasta.



| TABLE OF CONTENTS | | Pag. |
|---|--|------|
| Foreword and warnings | | 3/4 |
| PASTAFACILE components | | 4 |
| Sheet pastry machine accessories | | 5 |
| Assembling of adjustable guide support | | 5 |
| Assembling of accessories on sheet pastry machine | | 6 |
| Assembling of PASTAFACILE ratiomotor | | 6 |
| How to use PASTAFACILE and special functions | | 7 |
| Electrical connections | | 7 |
| Cleaning and maintenance | | 7 |
| In case of non-working | | 8 |
| After sales service facility and technical card | | 8 |

IMPORTANT SAFEGUARDS

When using electrical appliances, basic safety precautions should always be followed, including the following to reduce the risk of fire, electric shock, and/or injury to persons including the following:

1. Read all instructions
2. To protect against electric shock, do not place cord, plug, or appliance in water or other liquid
3. Close supervision is necessary when any appliance is used by or near children
4. Unplug from the outlet when not in use, before putting on or taking off parts, and before cleaning
5. Avoid contacting moving parts
6. Do not operate any appliance with a damaged cord or plug, or after the appliance malfunction, or is dropped or damaged in any manner.
Return appliance to the nearest authorized service facility for examination, repair or mechanical adjustment
7. The use of attachments not recommended or sold by the manufacturer may cause fire, electric shock or injury
8. Do not use outdoor
9. Do not let cord hang over edge of table or counter

-
10. Do not place near a hot gas or electric burner
 11. Always attach plug to appliance first, then plug cord into the wall outlet. To disconnect, turn any control to the off position, then remove plug from the wall outlet
 12. Use this appliance only for its intended use as described in this manual
 13. Keep the cord away from heated surfaces
 14. Use the ratiomotor New Pasta Facile only and exclusively on pasta making machines of IMPERIA's line (Sfogliatrice SP-150 and TITANIA) and their accessories, such as: sheet pastry cutting equipment (Accessory Simplex - Accessory Duplex)



Congratulations on your first-rate choice.



Use the ratiomotor New Pasta Facile only and exclusively on pasta making machines of Imperia's line (Sfogliatrici SP-150 and Titania) and their accessories.

WARNINGS - SAVE THIS INSTRUCTIONS

The present handbook is an integral part of the machine itself

Before making the machine work read carefully all the safety standards, instructions and security conditions mentioned hereinafter.

Any incorrect use of the machine not quoted from the present handbook is to be regarded as inaccuracy or mistake.

Any improper use of PASTAFACILE motor may cause serious danger.

Therefore, it is advisable to keep this handbook carefully and within reach, in order to look it up when needed.

CAUTION!

The ratiomotor "PASTA FACILE" has been designed for exclusively household use. Manufacturer is released from whatever responsibility in case of:

- improper use
- incorrect fitting
- unsuitable power supply
- modifications or operations not authorized by the manufacturer
- use of non original or unsuited spare parts

TAKE CARE!

In case of doubt about how to put the appliance into operation or how to use the machine, don't hesitate to contact your dealer.

On sending a communication don't forget to always indicate identification number and version of your appliance.

WARNINGS!

Setting up of PASTA FACILE motor into your hand operated machine converts it into a mechanized one: consequently HANDLE IT WITH CARE AND NOT AS A TOY.

USE THE APPLIANCE OUT OF CHILDRENS REACH

When using the machine wear neither clothes nor aprons, the strings or hems of which may get caught on the rotating rolls of the sheet pastry machine and its own accessories.

Apart from this and for sanitary measures pay attention to your hair (gather it up onto a knot and wear a protective cap) and jewels (i.e. thin chains, bracelets, etc).

Before setting up PASTA FACILE motor, lay the machine flat on an even and steady surface able to bear the weight.

Before making the appliance work, make sure to be able to stop it quickly in case of emergency.

Don't activate PASTA FACILE motor in case of:

- malfunction
- fall or damage
- damage to the supplying cable or plug

Don't plug the supply cable or the plug into water. Keep them out of hot surfaces.

Don't let the supply cable hang down from furniture or tables edge

Don't use this machine close to sinks or wet bases

GENERAL REMARKS

PASTA FACILE ratiomotor can be set up on hand operated pasta making machines of Imperia's line (Sfogliatrice SP-150 and Titania) sheet pastry machines and models belonging to other marks) and their accessories, such as:

sheet pastry cutting equipment (Accessory Simplex - Accessory Duplex)

PASTA FACILE does away with handle and clamps to fasten the machine to the work top.

PASTAFACILE COMPONENTS (Fig.1)

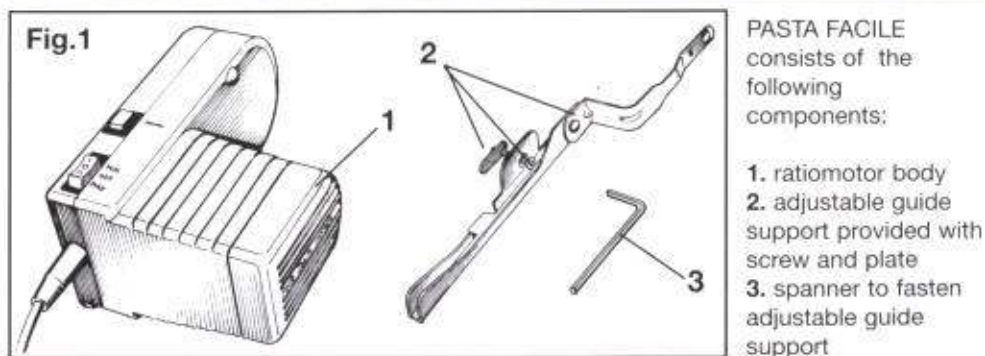

SHEET PASTRY MACHINES ACCESSORIES (Fig. 2)

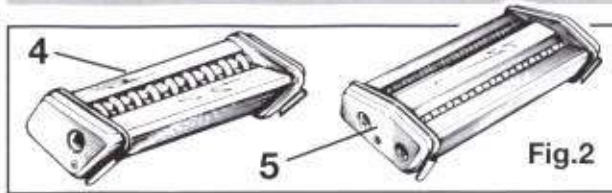

- 4. sheet pastry equipments belonging to "Simplex" range (single-edged)
- 5. sheet pastry equipments belonging to "Duplex" range (double-edged)

ASSEMBLING OF ADJUSTABLE GUIDE SUPPORT (Fig. 3/4)

Before starting work: follow carefully instructions specified in section "Cleaning and Maintenance" (pag.7)

Assembling of adjustable guide support

On sheet pastry machines with non-passing space for clamp seat (fig. 3)

control screwing of the plate (A) together with the screw (B) for a length of 5 mm, fit the guide support (C) against the sheet pastry machine (D), put the plate (A) into clamp seat space (E) aslant (like a button into a buttonhole). Screw in the screw in depth (B) by means of the special spanner (F) till tightening of the guide support (C). This one adjusts on the sheet pastry machine side.

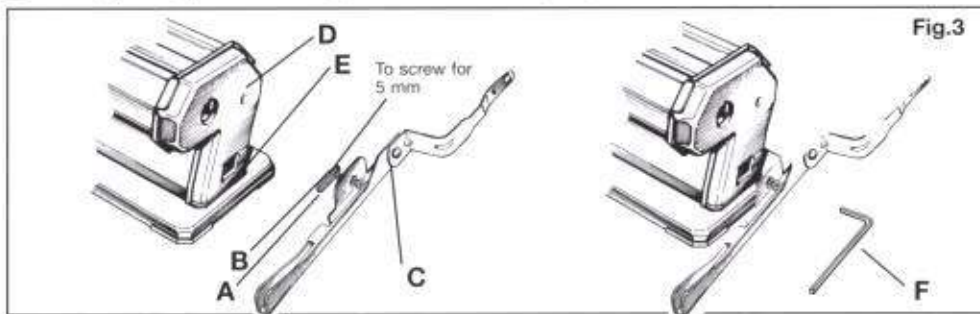

Assembling of adjustable guide support

On sheet pastry machines with passing space for clamp seat (fig. 4)

unscrew the plate (A) out of the screw (B), fir the guide support (C) against the side of the sheet pastry machine (D), keep the plate (A) leant to the inner part of the machine (against the passing space of the clamp seat (E)), fit the screw into the plate thread and screw it in depth by means of the special spanner (F) till complete tightening of the guide support.

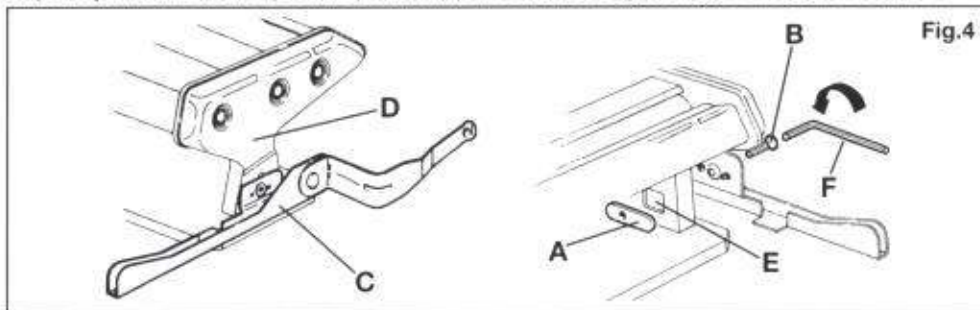

ASSEMBLING OF ACCESSORIES ON SHEET PASTRY MACHINES (Fig. 5)

Before using: follow carefully instructions specified in section "Cleaning and maintenance" (pag.7)
 After selection of the accessory required insert the accessory connecting feathers (G) into those ones of the sheet pastry machine (H), then push downwards and press gently till fastening the accessory with the sheet pastry machine tightly.

THE ACCESSORIES ASSEMBLING PROCESS IS VALID FOR ALL EQUIPMENTS SHOWN ON PAG 5 (Fig.2)

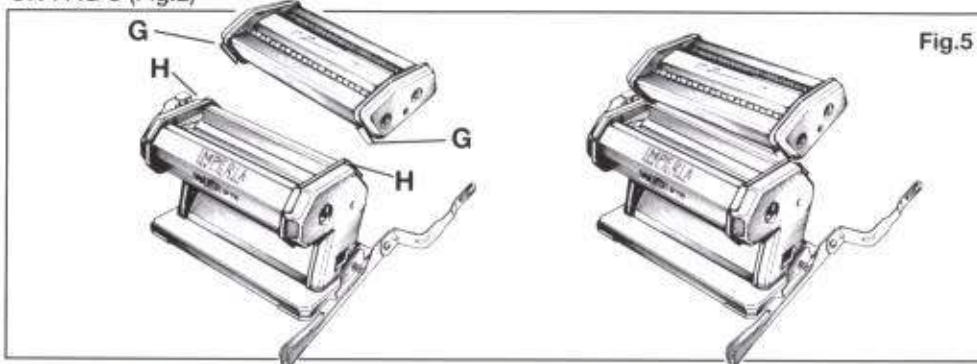

ASSEMBLING OF PASTAFACILE RATIOMOTOR (Fig. 6)

Before starting work: follow carefully instructions specified in section "Cleaning and maintenance" (pag.7)

CAUTION!

When carrying out assembling of PASTA FACILE ratiomotor, UNPLUG ALWAYS FROM OUTLET.

Assembling process

Insert PASTA FACILE pin with feather (M) into the handle hole seat (L) (made on all sheet pastry machine versions and their own accessories).

To make insertion easier, wheel the motor till both pin feathers and holes fit together perfectly.

After insertion push the pin deeply to the bottom.

Wheel PASTA FACILE counterclockwise, till the feather (N) enters the support guide groove (O) perfectly; then wheel the sealing handle (P) counterclockwise, till blocking and compressing PASTA FACILE ratiomotor against sheet pastry machine

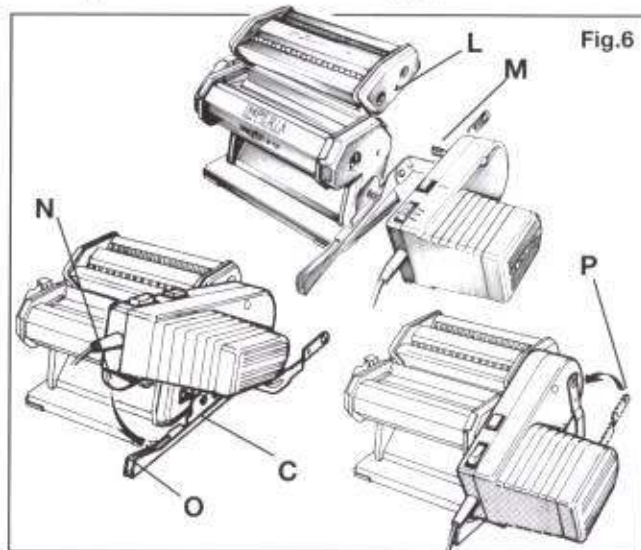

HOW TO USE PASTAFACILE RATIOMOTOR (Fig. 7)

IMPERIA PASTA FACILE ratiomotor is equipped with a 3 positions switch (S) and a push button (T) enabling intermittent working. S switch function keys

- Pos. I = MIN.** minimum speed
(working with accessories)
- Pos. 0 = OFF** rest status (motor doesn't run)
- Pos. II = MAX.** maximum speed (working with kneader and sheet pastry machine)

Use of min. or max. speed in operating conditions is left to user's own choice

Function keys of T push button enabling intermittent working this switch activates only when pressed on releasing this one PASTA FACILE motor stops.

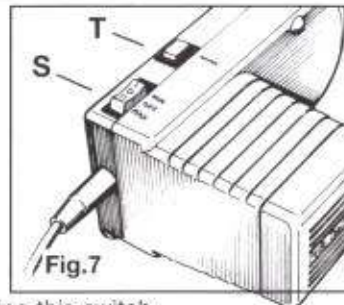

ELECTRICAL CONNECTION

Before actuating the appliance, check your home voltage (120 V - frequency 60 Hz). Any other power supply is not allowed.

Before plugging into the outlet, MAKE ALWAYS SURE TO POSITION THE SWITCH ON "0" (rest status) "This appliance has a polarized plug (one blade is wider than the other). To reduce the risk of electric shock, this plug will fit in a polarized outlet only one way. If the plug does not fit fully in the outlet, reverse the plug. If it still does not fit, contact a qualified electrician. Do not modify the plug in any way"

IN EMERGENCY

Place the switch to "0" (rest status) and unplug the supplying cable from outlet.

CLEANING AND MAINTENANCE BEFORE STARTING WORKS

Cleaning is the only scheduled maintenance operation to carry out regularly. Clean all the components generally used with the utmost care only by means of a dry cloth or a soft brush.

AFTER ASSEMBLING AND ACTUATING, CLEANING OF PASTA FACILE CAN BE ENDED UP BY PASSING A SMALL QUANTITY OF PASTA MIXTURE THROUGH THE ROTATING ROLLS OF THE SHEET PASTRY MACHINE (in order to remove any possible rest of dust) Cleaning of accessories used is recommended, too.

CAUTION

After cleaning throw the quantity of pasta used away.

NEVER wash PASTA FACILE ratiomotor, sheet pastry machine and its own accessories into jets of water or cleanse them with cleansers.

NEVER wash any component of these appliances in dishwasher.

CLEANING AND MAINTENANCE WHEN FINISHING WORK

PLACE PASTA FACILE SWITCH TO POSITION "0", THEN UNPLUG FROM OUTLET.

Clean all the components generally used with the utmost care only by means of a dry cloth or a soft brush, in order to remove any possible rest of pasta or flour.

NEVER remove remains of pasta or flour by means of kitchen utensils or pointed cutlery. NEVER wash PASTA FACILE ratiomotor, sheet pastry machine and its own accessories into water or cleanse them with cleansers.

Make sure that all the components are perfectly clean before putting them away.

imperia

Pasta Facile®

AFTER-SALES SERVICE FACILITY



The present appliance consists of fragile electrical parts; repairs are to be carried out only by skilled technical staff. Don't forget that guarantee lapses in case of

- repairs carried out by personnel non-qualified
- use of non-original components or spare parts
- appliance incorrectly used

TECHNICAL CARD

| VERSION | PASTA FACILE A-2500 |
|-------------------------|--|
| Dimensions | 11,5 x 14,8 x 23 cm |
| Net Weight | 1,1 kg |
| Supply voltage | 120 V 60 Hz |
| Rated output | 80 W |
| Feather revolving speed | 1st speed 40 r.p.m. 2nd speed 60 r.p.m. intermittent working 40 r.p.m. |

IN CASE OF NON-WORKING

Check that none of the underlisted malfunctions took place:

| DEFECT | POSSIBLE CAUSE | REMEDY |
|--|--|---|
| MOTOR DOESN'T START UP OR STOPS SUDDENLY? | A) APPLIANCE DISCONNECTED OR NOT PLUGGED IN A CORRECT WAY B) SWITCH POSITIONED ON "0" | A) PLUG CORRECTLY B) PRESS THE SWITCH AND PLACE IT EITHER ON I OR II |
| DOES RATIONOTOR UNDERGO AN ANOMALOUS SWINGING DURING WORK? | C) GUIDE SUPPORT NOT FASTENED STEADILY D) SEALING HANDLE OF SUPPORT GUIDE DOESN'T PRESS RATIONOTOR AGAINST SHEET PASTRY MACHINE | C) SECURE SUPPORT GUIDE TO THE SHEET PASTRY MACHINE IN A BETTER WAY D) POSITION THE SEALING HANDLE AS SPECIFIED IN ASSEMBLING PROCESS (fig. 6) |

Should not be possible to remove the defects noticed adopting the measures suggested, contact your IMPERIA reliable Official Dealer.

MADE IN ITALY

Imperia

10057 Sant'Ambrogio di Torino - Italia
www.imperia.com