

# Cuisinart®

INSTRUCTION AND RECIPE BOOKLET



Premier Series 9-Cup Food Processor

**DLC-2009CHB**

For your safety and continued enjoyment of this product, always read the instruction book carefully before using.

## Recommended work bowl capacity for various foods

<b>FOOD</b>	<b>CAPACITY</b>
Chopped fruits and vegetables	8 cups processed food
Chopped or puréed meat, poultry, fish or seafood	1¼ pounds meat, cut into 1-inch or smaller cubes, chilled
Bread dough	4 cups flour (32 ounces), yielding two 1-pound loaves
Pizza dough	3 cups flour (26 ounces), yielding three 12-inch pizzas
Nuts for nut butters	4 cups (20 ounces)
Sliced or shredded fruit, cheese, or vegetables	9 cups (total processed volume varies by food)
Cake batter	1 box 18.5 oz. cake mix batter for three 8-inch layers
Cookie dough	dough for about 50 cookies (2 pounds)
Thin liquids (such as custard for quiche or cheesecake batter)	2¾ cups
Thick liquids	6 cups
Puréed cooked fruits and vegetables	7 cups cooked, yielding approximately 4 cups thick purée
Puréed soft fresh fruits (berries, kiwis, peaches, etc.)	7 cups fresh, yielding approximately 4 cups thick purée

# IMPORTANT UNPACKING INSTRUCTIONS

This package contains a Cuisinart® Premier Series 9-Cup Food Processor, and the standard parts for it: Work bowl, work bowl cover, large and small pushers, dough blade, metal chopping/mixing blade, slicing disc, shredding disc, detachable disc stem for discs, spatula, How-to DVD and recipe/instruction book.

**CAUTION: THE CUTTING TOOLS HAVE VERY SHARP EDGES.** To avoid injury when unpacking the parts, please follow these instructions.

1. Place the box on a low table or on the floor next to the kitchen counter or table where you intend to keep the food processor. Be sure the box is right side up.
2. Remove the cardboard insert. You will see a rectangular block of plastic foam that holds the processor parts, each fitted into a cavity in the foam.
3. The detachable disc stem for the discs (A) sits in a cavity in one corner of the foam block. Remove this first.
4. The pusher assembly, with large and small pushers, (B) sits in the adjacent cavity. Remove this next.
5. The dough blade (C) rests in a cavity on the opposite side of the foam block. Remove it from the foam.
6. The plastic spatula (D) is on one long side of the foam block. Remove it next.
7. The slicing disc (E) is on the edge of one of the long sides of the foam block; the shredding disc (F) is on the other side. Slide them out **WITH GREAT CARE; THE BLADES ARE VERY SHARP.**
8. Lift out the DVD from its space on one side of the foam block.
9. Lift out the foam block.
10. Remove the instruction/recipe book.
11. The housing base with work bowl, metal blade and cover are at the bottom of the

box. The metal blade is loose in the work bowl beneath a foam insert. Do not reach into feed tube. Do not turn over work bowl without first removing metal blade. Remove work bowl cover by turning it clockwise and lifting.

12. Remove the base and bowl together by grasping the plastic bowl at the top with both hands and lifting the bowl straight up. Do not rotate the bowl clockwise on the base. This will cause the bowl to separate from the base.
13. Place the food processor on the counter or table. Remove foam cylinder insert from top of metal chopping blade. Read the instructions thoroughly before using the machine.
14. Save the shipping cartons and plastic foam blocks. You will find them very useful if you need to repack the processor for moving or other shipment.

**Please watch the enclosed How-to DVD before using the food processor.**

**NOTE: Remember to return your completed product registration card with all information carefully filled out.**

**WHEN REMOVING BLADE: CAREFULLY REMOVE THE METAL BLADE BY GRASPING THE CENTER WHITE HUB AND LIFTING IT STRAIGHT UP. NEVER TOUCH THE BLADES, AS THEY ARE RAZOR SHARP.**

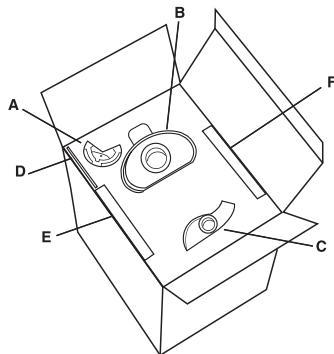

# CONTENTS

Recommended Work Bowl Capacities . . .	2	Cabbage and Iceberg Lettuce . . . . .	12
Unpacking Instructions . . . . .	3	Packing Feed Tube for Desired Results . . . . .	12
Important Safeguards . . . . .	5	Practicing Slicing and Shredding . . . . .	13
Introduction . . . . .	6	Removing Sliced or Shredded Foods . .	13
Machine Includes . . . . .	7	Slicing and Shredding Techniques . . . .	13
Assembly Instructions . . . . .	7	Small, Round Fruits and Vegetables . . .	13
Machine Functions . . . . .	8	Long Fruits and Vegetables . . . . .	13
Operating Instructions . . . . .	8	Small Amounts of Food . . . . .	13
Chopping, Puréeing & Mixing with Metal Blade . . . . .	9	French-Cut Green Beans . . . . .	13
Chop Raw Fruits and Vegetables . . . . .	9	Matchsticks or Julienne Strips . . . . .	13
Purée Fruits and Cooked Vegetables . . .	9	Cooked Meat and Poultry . . . . .	14
To Dislodge Food . . . . .	9	Uncooked Meat and Poultry . . . . .	14
Chop Hard Food . . . . .	9	Salami and Other Sausages . . . . .	14
Chop Fresh Herbs . . . . .	9	Slicing and Shredding Cheese . . . . .	14
Chop Peel from Citrus Fruit and Sticky Fruit Like Dates . . . . .	10	Kneading Yeast Dough with Dough Blade . . . . .	15
Chop Meat, Poultry and Seafood . . . . .	10	Machine Capacity . . . . .	15
Purée Meat, Poultry and Seafood . . . . .	10	Using the Right Blade . . . . .	15
Chop Nuts . . . . .	10	Measuring the Flour . . . . .	15
Make Peanut Butter, Nut Butters . . . . .	10	Proofing the Yeast . . . . .	15
Make Flavored Butters, Spreads and Dips . . . . .	10	Processing Dry Ingredients . . . . .	15
Make Mayonnaise . . . . .	10	Adding Liquids . . . . .	15
Beat Egg Whites . . . . .	11	Kneading Bread Dough . . . . .	16
Whip Cream . . . . .	11	Kneading Sweet Dough . . . . .	16
Make Crumbs and Crumb Crusts . . . . .	11	Rising . . . . .	16
Make Pastry . . . . .	11	Shaping, Finishing and Baking . . . . .	16
Make Quick Breads and Cakes . . . . .	11	Making Consecutive Batches . . . . .	16
Preparing Food For Slicing and Shredding . . . . .	12	Bread Dough Problems and Solutions . .	16
Round Fruits and Vegetables . . . . .	12	Sweet Dough Problems and Solutions . .	17
Whole Peppers . . . . .	12	Cleaning and Storage . . . . .	18
Large Fruits Like Pineapple . . . . .	12	For Your Safety . . . . .	19
		Technical Data . . . . .	19
		Warranty . . . . .	19
		Recipes . . . . .	21

Carefully read all instructions before using this appliance.

# IMPORTANT SAFEGUARDS

Always follow these safety precautions when using this appliance.

## Getting Ready

1. Read all instructions.
2. **Blades are sharp.** Handle them carefully.
3. Always unplug from outlet when not in use, before putting on or taking off parts, before removing food and before cleaning. To unplug, grasp plug and pull from electrical outlet. Never pull cord.
4. Do not use outdoors.
5. Do not let cord hang over edge of table or counter, or touch hot surfaces.
6. Do not operate any appliance with damaged cord or plug, or after appliance has been dropped or damaged in any way. Return appliance to the nearest authorized service facility for examination, repair, or electrical or mechanical adjustment.

## Operation

1. Keep hands as well as spatulas and other utensils away from moving blades or discs while processing food, to prevent the possibility of severe personal injury or damage to food processor. A plastic scraper may be used, but only when the food processor motor is stopped.
2. Avoid contact with moving parts. Never push food down into feed tube by hand when slicing or shredding. Always use pusher.
3. Make sure motor has completely stopped before removing cover. (If machine does not stop within 4 seconds after you remove the pusher assembly, unplug and call 1-800-762-0190 for assistance. Do not use the machine.)
4. Never store any blade or disc on motor shaft. To reduce the risk of injury, no blade or disc should be placed on the shaft except when the bowl is properly locked in place and the processor is in

use. Store blades and discs as you would sharp knives, out of reach of children.

5. Be sure cover and feed tube are securely locked in place before operating food processor.
6. Never try to override or tamper with cover interlock mechanism.

## Cleaning

To protect against risk of electrical shock, do not put base in water or other liquid.

## General

1. This appliance should not be used by or near children, or individuals with certain disabilities.
2. Do not operate this, or any other motor-driven appliance, while under the influence of alcohol or other substances that affect your reaction time or perception.
3. This food processor is UL listed for household use. Use it only for food preparation as described in the accompanying recipe and instruction book.
4. The use of attachments not recommended or sold by Cuisinart may cause fire, electrical shock or personal injury, or damage to your food processor.
5. To avoid possible malfunction of work bowl switch, never store processor with pusher assembly in locked position.
6. Maximum rating of 5.0 amperes is based on attachment that draws greatest current. Other recommended attachments may draw significantly less current.

**NOTICE:** This appliance has a polarized plug (one blade is wider than the other).

As a safety feature, this plug will fit in a polarized outlet only one way. If the plug does not fit fully in the outlet, reverse the plug. If it still does not fit, contact a qualified electrician. Do not attempt to defeat this safety feature.

# SAVE THESE INSTRUCTIONS FOR HOUSEHOLD USE ONLY

# INTRODUCTION

Congratulations on your purchase of a Cuisinart® Premier Series 9-Cup Food Processor. This product is the ultimate food preparation tool, and it comes from the originator of the American food processor, Cuisinart.

The Cuisinart® Premier Series 9-Cup Food Processor has all the elements of quality that Cuisinart is known for, including a powerful motor, the Supreme® Wide Mouth Feed Tube, and the longest warranty in the industry.

- **The Cuisinart® Supreme® Wide Mouth Feed Tube** is perfect for slicing whole fruits and vegetables without precutting.

This feature, plus the ability to use all of your existing Cuisinart specialty blades and discs, makes the Premier Series 9-Cup the select choice in food processors.



# THE MACHINE INCLUDES:

1. Housing base with a vertically projecting shaft and convenient touchpad control panel
2. 9-cup work bowl
3. Cover with Cuisinart® Supreme Wide Mouth Feed Tube
4. Pusher assembly that slides inside the feed tube
5. Dough blade
6. Sharp metal chopping/mixing blade
7. Serrated slicing disc
8. Shredding disc
9. Detachable stem for discs (not shown)
10. Plastic spatula (not shown)

The metal chopping blade chops raw and cooked fruits, vegetables, meat, fish and cheese to the exact consistency you want, from coarse to fine, even to a purée. It chops nuts, makes nut butters, mayonnaise and sauces, and mixes tender, flaky pastry. The metal chopping blade also mixes cakes, frostings, cookies, quick breads, muffins, and biscuits.

The slicing disc makes beautiful whole slices without torn edges. It slices whole fruits and vegetables, cooked meat, semi-frozen raw meat and loaves of bread.

The shredding disc processes most firm and hard cheeses into long, attractive shreds. It also shreds vegetables like potatoes, carrots and zucchini, and processes nuts and chocolate to a grated texture.

The detachable stem fits both discs, making disc storage compact in limited space.

The pusher assembly has two parts.

1. A small, removable, clear pusher that fits into a small center-located feed tube. This tube is for narrow food like carrots, for adding liquid, and for continuous feeding of small food like garlic.

2. A large pusher that fits into the Cuisinart® Supreme® feed tube opening and moves freely within it.

Upon contact, the large pusher meets an activating rod in the center of the work bowl handle, permitting the motor to start.

## ASSEMBLY INSTRUCTIONS

### Blade Operation

1. Plug in the housing base and place the work bowl on top, with the work bowl handle just to the left of center. Turn the work bowl counterclockwise to lock it onto the housing base.
2. **Carefully** lift and place the chosen blade over the work bowl center shaft. Line up the markings on the blade hub with the motor shaft. Blade should fit snugly and rest on the bottom of the work bowl.
3. Add desired ingredients to work bowl.
4. Place work bowl cover on work bowl, with the handle area just to the left of center. Turn counterclockwise to lock onto work bowl.
5. Align pusher assembly and activating rod with the feed tube opening on the work bowl cover and slide the activating rod down to the bottom.
6. You are now ready to operate the machine.

### Disc Operation

1. Plug in the housing base and place the work bowl on top, with the work bowl handle just to the left of center. Turn the work bowl counterclockwise to lock it onto the housing base.
2. Choose desired disc and place underside-up on tabletop. Pick up detachable disc stem and align it with the raised plastic crescent on the disc underside. The raised 'lock' indicator on the left corner of the stem should be to the left of the mounting plate on disc.
3. Turn the stem to the right, so the locking tabs are covered by the metal supports and a 'click' locks the stem in place.

4. With the stem facing down, place the assembly over the center hub. It should fit snugly and rest on the bottom of the work bowl.
  5. Place work bowl cover onto work bowl, with the handle area just to the left of center. Turn counterclockwise to lock onto work bowl.
  6. Align pusher with the feed tube opening on the work bowl cover and slide the activating rod down to the bottom.
  7. Use the cord wrap on the housing base underside to add or remove cord.
  8. You are now ready to operate the machine.
- Place the work bowl over the center stem, with the handle area just to the left of center. Turn counterclockwise to lock in place.
  - Insert the metal chopping blade and put ingredient pieces in the work bowl. Put on the cover and turn counterclockwise to lock onto work bowl. Align the pusher and the pusher's activating rod with the corresponding openings on the feed tube, and push all the way down.
  - Press and release the PULSE button two or three times. Each time the blade stops, let the pieces drop to the bottom of the bowl before you pulse again. This puts them in the path of the blade each time the motor starts.
  - Using the pulse/chopping technique, you get an even chop without overprocessing. Check the texture frequently by looking through the cover. If you want a finer chop, press and release the PULSE button until you achieve the desired texture.

## MACHINE FUNCTIONS

### PULSE

1. With the machine properly assembled and engaged, and ingredients in the work bowl, press the PULSE button repeatedly as needed.

### ON (Continuous)

1. Properly assemble and engage the machine.
2. To add ingredients through the feed tube, remove the pusher and fill the feed tube as directed (see Preparing Food for Slicing or Shredding, page 12).
3. Engage the pusher and press the ON button. The button light will turn on and the motor will start.
4. Press the pusher firmly down until all ingredients have passed into the work bowl. Remove the pusher and refill ingredients as needed.

When you engage the pusher again, the unit will automatically turn on.

5. Press the OFF button when finished.

## OPERATING INSTRUCTIONS

Try chopping some practice foods, such as a zucchini or potato, before you process food to eat. First, cut the ingredients into 1-inch pieces.

Onions and other food with a high water content will quickly end up as a purée, unless examined through the work bowl after each pulse to make sure they are not overprocessed.

Try chopping other food like meat for hamburger or sausage. Then make mayonnaise, pastry or bread, as described in the following sections.

To obtain consistent results:

Be sure all the pieces you add to the bowl are about the same size.

Be sure the amount you process is no larger than recommended on the inside cover of this booklet.

Before you do anything, wait for the blade to stop spinning. Once it does, turn the cover clockwise to unlock, and remove by lifting it off.

Remove the bowl from the base of the machine before removing the blade. This creates a seal to prevent food from leaking. Turn the bowl clockwise to unlock from the base, and lift straight up to remove.

To prevent the blade from falling from the work bowl onto your hand when emptying the work bowl, use one of the following methods:

Be sure your hands are dry. Grab the blade hub, and remove the metal blade before tilting the bowl, using a spatula to scrape off any food. Then carefully lift the blade out of the work bowl. **Or** insert your finger through the hole in the bottom of the work bowl, gripping the blade from the bottom, and grip the outside of the work bowl with your thumb. **Or** hold the blade in place with your finger or spatula while pouring out food.

## TECHNIQUES FOR CHOPPING AND PURÉEING WITH THE METAL BLADE

### To chop raw fruits and vegetables

First cut the food into 1-inch (2.5cm) pieces. You get a more even chop when all pieces are about the same size. Put no more than the recommended amount of food into the work bowl (see table inside front cover). Lock the cover in place. Press the PULSE button at the rate of 1 second on, 1 second off, until the food is coarsely chopped. For more finely chopped results, hold the PULSE button, letting the machine run continuously until the desired consistency has been reached. Check frequently to avoid overprocessing. Use the spatula to scrape down the sides of the work bowl if necessary.

### To purée fruits and cooked vegetables

First, cut the food into 1-inch (2.5cm) pieces. You get a smoother purée faster when all pieces are about equal in size.

Put no more than the recommended amount of food in the work bowl (see table inside front cover). Lock the cover in place. PULSE to chop coarsely, then press the ON button and process continuously until food is puréed. (**NOTE:** Cooked potatoes are an exception to this procedure. They develop a gluey texture when processed with the metal blade.)

When making soup, you will want to purée vegetables that have been cooked in liquid. Don't add the liquid to the work bowl, just the cooked vegetables; remove vegetables with a slotted spoon. They will purée faster and smoother without liquid. Then add just enough liquid to make the purée pourable, return to the soup liquid and stir to combine.

### To dislodge food

Occasionally, a piece of food may become wedged between the blade and the work bowl. If this happens, unplug the machine, remove the cover, lift the blade out carefully and remove the wedged piece. Empty the bowl, reinsert the blade and lock the cover and pusher into place. Press the ON button and drop the food pieces through the small feed tube opening while the machine is running. After adding a cupful this way, add the remaining food to the bowl and process in the usual manner.

### To chop hard foods

To chop hard food like garlic and hard cheese, assemble the unit, remove the small pusher, press the ON button and drop the food through the small feed tube while the machine is running. Small foods like garlic can be dropped in whole. Large foods like hard cheese should be cut into 1-inch (2.5cm) pieces. This method of processing minces garlic, shallots and onions. Hard cheese and coconut will have the same texture as if they had been hand grated.

**IMPORTANT:** Never try to process cheese that is too hard to cut with a knife. You may damage the blade or the machine.

### To chop parsley and other fresh herbs

The herbs, the work bowl and the metal chopping blade must all be thoroughly clean and dry. Remove stems from herbs. Add leaves to bowl and process, using the PULSE button until chopped as fine as desired. The more herbs you chop at a time, the finer chop you can obtain. If completely dry when chopped, parsley and other herbs will keep for at least 4-5 days, stored in an airtight bag in the refrigerator. They may be frozen for months, stored in an airtight container or bag.

**To chop peel from citrus fruit or to chop sticky fruit like dates or raisins**

For citrus, remove only the peel with a vegetable peeler, not the white pith, which is bitter tasting. Cut the peel into lengths of 2 inches (5cm) or less and process with ½ cup (125 ml) of granulated sugar until finely chopped. This may take 2 minutes or longer.

For sticky fruit like dates, raisins, prunes and candied fruit, first freeze the fruit for about 10 minutes. Add some of the flour called for in the recipe to the fruit. Use no more than 1 cup (250 ml) of flour for each cup of fruit.

**To chop meat, poultry and seafood**

The food should be very cold, but not frozen. Cut it into 1-inch (2.5cm) pieces to ensure an even chop. Using the ON button, process no more than the recommended amount at one time (see table inside front cover). Press the PULSE button 3 or 4 times at a rate of 1 second on, 1 second off. If the food is not chopped fine enough, let the processor run continuously for a few seconds. Check the texture often to avoid overprocessing. Use a spatula to scrape food from the sides of the bowl as necessary.

**To purée meat, poultry and seafood**

Prepare the food as described above. Press the PULSE button until evenly chopped, then process continuously to the desired texture. Scrape the bowl with a spatula as needed. Leave the purée in the work bowl and add eggs, cream and seasonings as called for by the recipe. Process to combine thoroughly.

Remember, you control texture by the length of time you process. By varying the processing time, you can get a range of textures suitable for hamburgers, hash, stuffed peppers, or smooth mousses.

**To chop nuts**

Chop no more than the recommended amount at one time. Press and release the PULSE button and check frequently to avoid nuts clumping together in a nut butter. When a recipe calls for flour or sugar, add some to the nuts before you chop, about ½ cup for each cup of nuts. This allows you to chop the nuts as fine as you want without turning them into a nut butter. You can also chop nuts with a shredding or slicing disc. The optional fine shredding disc is particularly good.

**To make peanut butter and other nut butters**

Process up to the recommended amount of nuts. Using the ON button, let the machine run continuously.

After 1½ to 2 minutes, the ground nuts will form a ball that will gradually smooth out. Scrape the sides of the bowl and continue processing until drops of oil are visible. Taste for consistency. The longer you process, the softer the butter. For chunk style, add a handful of nuts just after the ball of nut butter begins to smooth out. To make cashew butter, add a little bland vegetable oil. Processor nut butters contain no preservatives. Store in refrigerator to keep from separating.

**To make flavored butters, spreads and dips**

Cut room temperature butter into tablespoon size pieces. Finely chop flavoring ingredients first, such as anchovies, cheese, herbs, etc. Be sure work bowl is clean and dry. Add small hard ingredients like garlic and hard cheese through the feed tube while machine is running. Next, add the butter and process using the ON button, until smooth.

Add any liquid ingredients last, while the processor is running, and process just long enough to blend. Process ingredients for spreads and dips the same way. They should be at room temperature and cut into 1-inch (2.5cm) cubes, or added by tablespoonfuls.

**To make mayonnaise**

You can make foolproof homemade mayonnaise with your Premier Series 9-Cup Food Processor. The work bowl and metal blade must be clean and dry.

Foods prepared with raw eggs may contain salmonella or other potentially harmful bacteria. Because egg yolks are a fine growth medium for bacteria, we recommend that you cook them for use in mayonnaise, Hollandaise sauce, Caesar salad dressing, chilled soufflés, chilled chiffons, mousses and other recipes calling for raw egg yolks. For mayonnaise, we recommend using either the “cooked egg” mayonnaise on page 31, or using the following method with pasteurized liquid eggs.

For a “one egg” batch of basic mayonnaise made with pasteurized liquid eggs, place ¼ cup pasteurized liquid eggs, 2 tablespoons wine vinegar or lemon juice, 1 teaspoon dry mustard, ½ teaspoon kosher salt and a pinch of ground white pepper in the work bowl. With the machine running, add ½ cup of vegetable oil to the small pusher and allow to slowly drip into the mixture while processing. After all the oil has dripped through, add another ½ cup of vegetable oil to the small pusher and allow to drip through. The mixture will form a thick emulsion. For variation, you may experiment with using flavored vinegars, adding chopped fresh herbs, dry herbs, or roasted garlic to taste. To make your mayonnaise a little lighter, add some well-drained plain fat-free yogurt to taste.

### **To beat egg whites**

The work bowl must be absolutely clean. Add 3 or more egg whites (up to 6 large egg whites) and press the ON button. Add about 1 teaspoon of lemon juice or vinegar for every egg white. Vinegar makes stiffer whites; its flavor is hardly detectable in cakes or soufflés. Continue processing until the egg whites hold their shape, about 1½ to 2½ minutes.

### **To whip cream**

Processor whipped cream holds its shape very well. It is good for decoration or as a topping; however, it will not whip to the light, fluffy consistency obtained by methods that beat in more air. Chill the cream well before starting. Process continuously using the ON button, until it begins to thicken. Then add sugar as desired and continue processing, watching carefully for the desired consistency.

For consistently reliable results, add 2 tablespoons (30 ml) of nonfat dry milk for every cup of cream before whipping.

### **To make crumbs and crumb crusts**

Cut or break bread, crackers or cookies into 1-inch pieces and place in work bowl. Press the ON button and process continuously until pieces reach the desired texture.

For seasoned crumbs, chop parsley or other fresh herbs with the crumbs. For buttered crumbs, process until the dry crumbs are of the desired texture, then drizzle melted butter through the small feed tube opening while the machine is running. For crumb crusts, process crackers or cookies as described above. Add sugar, spices and butter, and cut into pieces as specified by your recipe. Process until well combined.

### **To make pastry**

Combine unbleached all-purpose flour, salt and pieces of very cold butter in the work bowl. Process to the consistency of cornmeal. Sprinkle evenly with the minimum amount of cold liquid in the recipe. PULSE 5 or 6 times. The dough should begin to hold together when pressed. If it is still dry and crumbly, add more water – 1 teaspoon at a time – until the dough holds together easily. Do not let the dough form a ball in the processor or it will be overworked and tough. Form into a round disc, one inch thick, and wrap in plastic wrap. Refrigerate for 1 hour before using, or double wrap and freeze for later use.

### **To make quick breads and cakes that use baking powder and/or soda**

The most important rule for success is not to overmix after adding the flour. The ingredients for these soft doughs should be cold, except butter. If the recipe calls for chopped ingredients like lemon peel or nuts, chop them first while the work bowl is clean and dry, then set aside until needed.

Put dry ingredients like flour, salt and leavening in the work bowl and process with the metal blade for 5 seconds to mix. Remove and reserve the dry ingredients.

Add the eggs and sugar to the work bowl and, using the ON button, process to mix, letting the machine run about 1 minute. Next, add butter. Cut into 1-inch pieces at room temperature. Run machine continuously for a minute, until the butter is thoroughly mixed with the sugar and eggs. Then add flavoring and liquid – vanilla, spices, cocoa, etc. Process until mixed. Add the dry ingredients to the work bowl.

Process by pulsing, inspecting after each pulse. Stop pulsing as soon as the dry ingredients have almost disappeared into the batter. Overprocessing will cause quick breads and cakes to be tough. (If your recipe calls for ingredients that are to be coarsely chopped – like raisins or nuts – add them last with the mixed dry ingredients.)

### **To make cake mix**

Your food processor work bowl is large enough for the preparation of an 18.5-ounce packaged cake mix. Insert the metal blade and add the cake mix to the work bowl. Press the ON button and while the machine is running, add the eggs and liquid through the small feed tube and process for 5 seconds. Scrape down the sides of the work bowl and process 1 minute more for maximum volume. Do not remove the metal blade. Insert a finger into the underside of the blade from the bottom of the work bowl to hold the blade in place while emptying the batter.

**Tip:** After emptying cake batter or puréed soup from the work bowl, replace the bowl on the motor base and PULSE once. Centrifugal force will spin the batter off the blade onto the sides of the work bowl. Remove the blade, and use the spatula to scrape any remaining batter from the bowl.

## **PREPARING FOOD FOR SLICING AND SHREDDING**

For disc assembly instructions, refer to Assembly Instructions.

### **Round fruits and vegetables**

Before processing onions, apples and other large, round fruits and vegetables, cut the bottom ends flat to make the food lie stable on the disc.

Place the food in the feed tube, flat side down, as far left as possible, to prevent it from tilting when being processed. Choose fruits that are firm and not too ripe.

Remove large hard pits and seeds from fruits before processing. Seeds from citrus fruits need not be removed. Remove the rind before slicing or shredding, if desired.

### **Whole peppers are an exception**

Remove the stem and cut the stem end flat. Remove the core and scoop out the seeds. Leave the end opposite the stem whole, to keep the structure stiff. This ensures round, even slices.

### **Large fruits like pineapple**

Cut the ends flat, cut in half, and either core or remove the seeds. If necessary, cut the halves into smaller pieces to fit the feed tube.

### **Cabbage and iceberg lettuce**

Turn the head on its side and slice off the top and bottom, leaving a center section about 3 inches (8cm) deep. Remove the core, then cut in wedges to fit the feed tube. Remove the core from the bottom and top pieces and cut into wedges to fit into the feed tube.

The optional 2mm and 1mm slicing discs are excellent for slicing cabbage for coleslaw.

If the fruit or vegetable doesn't fit, try inserting it from the bottom of the feed tube, where the opening is slightly larger.

### **Pack the feed tube for desired results.**

For long slices or shreds, cut the food into feed-tube widths and pack the pieces horizontally.

For small, round slices or short shreds from carrots, zucchini and other long vegetables, cut in feed tube heights and pack tightly upright.

Food should fit snugly, but not so tightly that it prevents the pusher from moving.

When slicing or shredding, always use the pusher.

### **Never put your fingers or a spatula into the feed tube.**

Never push down hard on the pusher. Use light pressure for soft fruits and vegetables like bananas, mushrooms, strawberries and tomatoes, and for all cheese. Use medium pressure for most food: apples, celery, citrus fruit, potatoes and zucchini. Use firm pressure for hard vegetables like carrots and yams.

# PRACTICING SLICING AND SHREDDING

1. Insert a slicing or shredding disc, put the cover on the work bowl and insert the food in the feed tube.
2. Slide the pusher into place, and apply pressure to the pusher while pressing down the PULSE button. Release the button as soon as the food is sliced or shredded.
3. You can load the feed tube repeatedly without removing work bowl cover. Simply grasp the pusher and lift up. The pusher assembly will come off easily, leaving the cover and feed tube in place. Your other hand is free to reload the feed tube, and you do not need to press the ON button if it was previously selected.

## REMOVING SLICED OR SHREDDED FOOD

Before you do anything, wait for the disc to stop spinning. When it does, unplug the unit, then hold the work bowl handle and turn it clockwise. Then lift; the work bowl and cover will come off together. Turn cover clockwise to unlock from work bowl. Lift, remove, invert and place on counter space.

### Remove the slicing or shredding disc.

Place two fingers under each side of the disc and lift it straight up. Place the disc on top of the inverted work bowl cover to minimize drips and spills.

## TECHNIQUES FOR SLICING AND SHREDDING

### Small, round fruits and vegetables

For large berries, radishes and mushrooms, trim the bottom ends flat with a knife. Insert the food through the feed tube, standing each piece on a flat end. You can fill the tube to about 1 inch (2.5cm) from the top.

The bottom layer gives you perfect slices for garnish. If you want all the slices to be perfect, it's best to process one layer at a time.

### Long fruits and vegetables

Trim foods like bananas, celery and zucchini by cutting them into pieces slightly shorter than the feed tube. Cut both ends flat. (Use a ruler as a guide, or the pusher assembly.) Fill the feed tube with the pieces, standing them vertically and adding enough pieces so they are solidly packed and cannot tilt sideways as they are sliced or shredded.

### Small amounts of food

Use the small feed tube and the small pusher. Remove the small pusher from the pusher assembly. Place the pusher assembly onto the feed tube and press the sleeve all the way down.

Cut the food in lengths slightly shorter than the feed tube. If slicing one or two long, thin vegetables like carrots, push them to the far left. If you are slicing a few vegetables that are wide at one end and narrow at the other (carrots, celery or scallions) cut them in half and pack in pairs, alternating one wide end up, one narrow end up.

### French-cut green beans

Trim fresh green beans to feed-tube widths. Stack in the feed tube horizontally to about one inch from the top. Use the slicing disc, apply light pressure to the pusher and press the PULSE button until beans are sliced.

To make long, horizontal slices of raw zucchini or carrots, use the same procedure.

### Matchsticks or julienne strips

Process the food twice – 'double slice' it. Insert large fruits or vegetables (potatoes, turnips, zucchini, apples) in the feed tube.

Cut pieces to fit the feed tube horizontally from end to end. Apply pressure to the pusher while pressing the PULSE button until the food is sliced. You will get long slices.

Remove the slices from the work bowl and reassemble. The slices should be assembled horizontally with cut edges facing front and back. Reinsert them in the feed tube, wedging them in tightly. Slice them again. You will obtain long julienne strips.

With the optional square julienne disc, you can make square julienne strips in one operation.

### **Cooked meat and poultry**

The food must be very cold. If possible, use a piece of food just large enough to fit in the feed tube. To make julienne strips of ham, bologna or luncheon meat, stack slices, then roll or fold them double and stand upright in the feed tube, wedging in as many rolls as possible. This technique works better with square or rectangular pieces than with round ones.

### **Uncooked meat and poultry**

Cut the food into pieces to fit the feed tube. Boneless, skinned chicken breasts will usually fit when cut in half crosswise. Wrap the pieces in plastic wrap and put them in the freezer. They are ready to slice when they are easily pierced with the tip of a sharp knife, although semi-frozen and hard to the touch. Remove plastic wrap. Stand them in the feed tube, cut side down, and slice them against the grain, using firm pressure on the pusher. Or lay them flat in the feed tube, as many as will fit, and slice with the grain, using firm pressure.

### **Salami and other sausages**

If the sausage is soft, freeze it until hard to the touch but easily pierced with the tip of a sharp knife. Hard sausages need not be frozen. Use the small feed tube if the sausage is thin enough to fit. Otherwise, cut the sausage into pieces to fill the large feed tube completely. Stand the pieces vertically, packing them tightly so they cannot tilt sideways.

### **Firm cheese like Swiss and Cheddar**

Cut the cheese into pieces to fit the feed tube. Put it in the freezer until semi-frozen, hard to the touch but easily pierced with the tip of a sharp knife. Stand the pieces in the feed tube and apply light pressure to the pusher.

**IMPORTANT:** Never try to slice soft cheese like mozzarella or hard cheese like Parmesan. You may damage the slicing disc or the food processor itself. You can successfully shred most cheeses except soft ones. The exception is mozzarella, which shreds well if thoroughly chilled.

Hard cheeses like Parmesan shred well only at room temperature. Therefore, only attempt to slice or shred mozzarella when well chilled, and Parmesan when at room temperature.

---

## **SLICING AND SHREDDING CHEESE**

TYPE OF CHEESE	CHOP/PUREÉ	SHRED	SLICE
<b>Soft</b>			
Brie, Camembert, room temperature	yes	no	no
Mozzarella chilled 15-20 min in freezer	no	yes	no
Ricotta, room temperature	yes	no	no
Cottage, Cream	yes	no	no
<b>Semi-Soft</b>			
Blue, chilled	yes	yes	no
Fontina, chilled	yes	yes	no
Bel Paese, chilled	yes	yes	no
<b>Semi-Hard</b>			
Cheddar, chilled	yes	yes	yes
Monterey Jack, Longhorn, chilled	yes	yes	yes
Swiss, Jarlsberg, chilled	yes	yes	yes
Edam, Gouda, chilled	yes	yes	yes
Provolone, chilled	yes	yes	yes
<b>Hard, at room temperature</b>			
Parmesan, Romano, Locatelli	yes	yes	no
Pecorino, Asiago	yes	yes	no

\*Soft and semi-soft cheeses will pureé; semi-hard and hard cheeses will chop.

# TECHNIQUES FOR KNEADING YEAST DOUGH WITH THE DOUGH BLADE

The Premier Series 9-Cup Food Processor is designed to mix and knead dough in a fraction of the time it takes to do it by hand. You will get perfect results every time if you follow these directions.

## **NEVER TRY TO PROCESS DOUGH THAT IS TOO STIFF TO KNEAD COMFORTABLY BY HAND.**

There are two general types of yeast dough. Typical bread dough is made with a flour mix that contains at least 50% white flour. It is uniformly soft, pliable and slightly sticky when properly kneaded.

It always cleans the inside of the work bowl completely when properly kneaded.

Typical sweet dough contains a higher proportion of sugar, butter and/or eggs than typical bread dough. It is rich and sticky and it does not clean the inside of the work bowl.

It requires less kneading after the ingredients are mixed. Although 30 seconds are usually sufficient, 60 to 90 seconds give better results if the machine does not slow down. Except for kneading, the processing procedures are the same for both types of dough.

### **Machine capacity**

Recommended maximum amount of flour is 4 cups of all-purpose flour or 2½ cups of whole-grain flour. If a bread dough calls for more than the recommended amounts of flour, mix and knead it in equal batches. Do the same for sweet doughs that call for more than 3½ cups of flour.

### **Using the right blade**

Use the dough blade when the recipe calls for more than 3½ cups (17½ ounces/875 ml) of flour. Use the metal chopping blade when a recipe calls for less than 3½ (875 ml) cups of flour.

Because the dough blade does not extend to the outside rim of the work bowl, it cannot pick up all the flour when small amounts are processed.

### **Measuring the flour**

It's best to weigh it. If you don't have a scale, or the recipe does not specify weight, measure by the stir, scoop and sweep method. Use a standard, graduated dry measure, not a liquid measuring cup.

With a spoon or fork, stir the flour in its container. Do not measure flour directly out of the bag; it is too packed to get an accurate measure. With the dry measure, scoop up the flour so it overflows. With a spatula or knife, sweep excess flour back into the container so the top of the measure is level.

Do not pack flour into the dry measure.

### **Proofing the yeast**

The expiration date is marked on the package. To be sure your yeast is active, dissolve it in a small amount of warm liquid (about ⅓ cup [75 ml] for one package of dry yeast). The temperature of liquid used to dissolve and activate yeast must be between 105° and 115°F (40° and 46°C). Yeast cells are not activated at temperatures lower than this and they die when exposed to temperatures higher than 130°F (54°C).

If the recipe includes a sweetener like sugar or honey, add a teaspoon with the yeast. If no sweetener is called for, add a pinch, or add a pinch of flour. The yeast won't foam without it. Let the mixture stand until it foams, up to 10 minutes. If it does not foam, discard and begin again with fresh yeast.

### **Processing dry ingredients**

Put the flour in the work bowl with all the other dry ingredients. If the recipe calls for herbs, oil or solid fats like butter, add them with the flour. Turn the machine on and let it run for about 20 seconds. (Cheese, nuts and raisins may be added with the dry ingredients or during the final kneading. To leave them almost whole, add them 5 seconds before you stop kneading. For a finer texture, add them sooner.)

### **Adding liquids**

All liquid should be added through the small feed tube while the machine is running. Add liquid in a slow, steady stream, only as fast as dry ingredients absorb it. If liquid sloshes

or splatters, stop adding it but do not turn off the machine. Wait until ingredients in bowl have mixed, then add remaining liquid slowly. Pour liquid onto dough as it passes under feed tube opening. Do not pour liquid directly onto bottom of bowl.

Follow the recipe carefully. It is important to add enough liquid to make the dough soft enough to knead. Kneading dough that is too stiff can strain the machine.

All liquid except that used to activate yeast should be cold, to minimize the possibility of overheating the dough. You must never knead a yeast dough to a temperature higher than 100°F (37°C). Doing so will slow or even prevent the action of the yeast.

### **Kneading bread dough**

Do not try to use the machine to knead dough that is too stiff to knead comfortably by hand. Doing so can strain the machine.

After the dough starts to clean the inside of the work bowl completely and forms a ball, process it for 60 seconds to knead it. Stop the machine and test the dough to be sure it's properly kneaded. Typical bread dough should have a soft, pliable texture and it should feel slightly sticky. Stretch the dough with your hands to test it. If it feels hard, lumpy or uneven, continue processing until it feels uniformly soft and pliable. Make sure that the blade is firmly pressed back into place after removing the dough to test it.

### **Kneading sweet dough**

Process dough for at least 30 seconds after all the ingredients have been incorporated. It will not clean the inside of the work bowl. If necessary, scrape the bowl and process for 5 more seconds.

### **Rising**

Put the dough in a large, resealable lightly floured plastic bag. Squeeze out all the air and seal, allowing space for the dough to rise.

Or put the ball of dough in a large bowl coated with soft butter or vegetable oil. Roll the dough around to coat its entire surface. Cover it with a damp towel or a piece of oiled plastic wrap.

Let it rise in a warm, draft-free place, about 80°F (26°C). The rising time is usually about

1½ hours but will vary from 45 minutes to several hours, depending on the type of flour and the humidity in the air. To test whether the dough has risen enough, stick a finger in it. An indentation should remain. If it doesn't, let the dough rise more and test again.

When it has risen enough, punch the dough down.

### **Shaping, finishing and baking**

If you shape the dough in loaf pans, fill pans only half full. Let rise until dough is just slightly above the top of the pan. If shaping free-form loaves, let them rise on an oiled baking sheet until at least doubled in bulk.

### **Making consecutive batches**

You can make several batches of bread dough in a row. The motor in the Premier Series 9-Cup Food Processor is extremely efficient.

## **TYPICAL BREAD DOUGH PROBLEMS AND SOLUTIONS**

### **If dough blade doesn't incorporate ingredients**

Always start processor before adding liquid. Add liquid in slow, steady stream, only as fast as dry ingredients absorb it. If you hear liquid sloshing, stop adding it but do not turn off machine. Instead, wait until ingredients in work bowl have mixed, then add remaining liquid slowly. Pour liquid onto dough as it passes under feed tube; do not pour liquid directly onto bottom of work bowl.

### **If blade rises in work bowl**

Blade may not have been pushed down as far as possible before processing started.

Excessively sticky dough can cause blade to rise even though it cleans inside of work bowl.

If dough feels very sticky, reinsert blade and immediately add 2 tablespoons (30 ml) flour through small feed tube while machine is running.

### **If dough doesn't clean inside of work bowl**

- Amount of dough may exceed maximum capacity of your food processor. Remove half and process in 2 batches.
- Dough may be too dry. If it feels crumbly, add water, 1 tablespoon (15 ml) at a time, while machine is running, until dough becomes moist and cleans inside of work bowl. Wait 10 seconds between additions of liquid.
- Dough may be too wet. While machine is running, add 1 tablespoon (9 gm) of flour. If necessary, add more, 1 tablespoon (9 gm) at a time, until dough cleans inside of work bowl and forms a ball.
- Dough blade is intended only for recipes calling for at least 3½ cups of flour (17½ ounces/496 gm). If your recipe calls for less flour, remove metal dough blade and insert metal chopping blade. Always use metal chopping blade for recipes calling for less than 3½ cups (496 gm) of flour, such as pizza dough.

### **If nub of dough forms on top of blade and does not become uniformly kneaded**

Stop machine, carefully remove dough, divide into 3 pieces and redistribute evenly in work bowl. Continue processing until dough is uniformly soft and pliable.

### **If dough feels tough after kneading**

Divide dough into 2 or 3 pieces and redistribute evenly in bowl. Process 10 seconds or until uniformly soft and pliable.

### **If soft dough or liquid leaks onto base of food processor**

Always start processor before adding liquid and add liquid only as fast as dry ingredients absorb it.

### **If motor stops**

- Cover may have become unlocked.
- Power cord may have become unplugged.
- Excessive strain may have caused motor to overheat and stop. Wait for the motor to cool, 5 to 10 minutes. A safety protector in the motor prevents excessive overheating. If the motor stops, turn machine off. After 5-10 minutes, divide

dough into 2 batches and complete processing. Pinch dough to make sure that it is not too stiff to knead comfortably by hand. If it is, add liquid, 1 teaspoon (5 ml) at a time, until dough is sufficiently moist to clean inside of bowl.

### **If dough doesn't rise**

We recommend you always test activity of yeast before using, by stirring it and at least ½ teaspoon (2 ml) sugar into about ⅓ cup (75 ml) warm liquid (105-120°F) (40-48°C). Within 10 minutes foam should develop, indicating yeast is active. Do not use dry yeast after expiration date on package.

Do not use warmer water, or overheat dough with excessive kneading, as it may kill the yeast cells. All other liquid should be cold.

Don't knead so long that dough becomes overheated. The ideal temperature for kneaded dough is 80°F (26°C); it should never exceed 100°F (37°C).

Let dough rise in draft-free environment of about 80-90°F (26-32°C).

Dough containing whole grain flour will take longer to rise than dough made of white flour only.

### **If baked bread is too heavy**

Next time, feel dough to be sure it is uniformly soft, pliable and slightly sticky, before setting aside to rise. Let dough fully double in bulk in bowl or bag, punch it down, then let it double again after it is shaped.

## **PROBLEMS AND SOLUTIONS WITH TYPICAL SWEET DOUGHS**

### **If motor slows down**

- Amount of dough may exceed maximum capacity. Remove half, and process in 2 batches.
- Don't process too long after all ingredients are incorporated.

Rich doughs will give you good results after only 30 seconds of kneading.

**If blade doesn't incorporate ingredients**

Butter or margarine, if not melted, must be cut into tablespoon-size pieces before being added to work bowl.

**If dough blade rises in work bowl**

Blade may not have been pushed down as far as possible before processing started. Machine may be overloaded. Remove half of dough and process in 2 batches.

**If motor stops**

See comments under 'Typical Bread Dough' Problems and Solutions, page 16.

**If dough doesn't rise**

See comments under 'Typical Bread Dough' Problems and Solutions, page 16.

## CLEANING AND STORAGE

Keep your food processor ready to use on a kitchen counter. When not in use, leave it unplugged.

Store the blades and discs as you would sharp knives, out of the reach of children.

The disc and blade holders are optional accessories which offer safe and convenient storage.

All parts except the housing base are dishwasher safe, and we recommend washing them in the dishwasher on the top rack. Due to intense water heat, washing the work bowl and work bowl cover on the bottom rack of your dishwasher may cause damage over time. Insert the work bowl upside down. Remember to unload the dishwasher carefully wherever you place sharp blades and discs.

To simplify cleaning, rinse the work bowl, cover, pusher assembly and blade or disc immediately after use so food won't dry on them. Openings at the bottom of the large pusher provide drainage and make cleaning easy. If food lodges in the pusher, remove it by running water through it, or use a bottle brush.

If you wash blades and discs by hand, do it carefully. Avoid leaving them in soapy water where they may disappear from sight. To clean the metal blade, fill the work bowl with soapy water, hold the blade by its plastic center and move it rapidly up and down on the center shaft of the bowl.

Use of a spray attachment is also effective. If necessary, use a brush.

The work bowl is made of Lexan® (plastic), which is shatter resistant and heat resistant. It should not be placed in a microwave oven, as the aperture at the front of the pusher houses the metal rod that activates the motor.

**TIP:** When preparing a meal, make the dishes with the smallest amount of wet ingredients first.

For example, make the bread first; then you don't need to wash the bowl before making the salad.

In many cases, wiping the bowl with a paper towel between recipes is sufficient.

Chopping certain foods may scratch or cloud the work bowl. These foods include ice, whole spices, coffee beans and oils like wintergreen. If you like to prepare your own spice blends, you may want to keep a second bowl just for that purpose.

The housing base is made of a tough plastic with high impact resistance. Its smooth surface will look new for years. Keep a sponge handy as you work, and wipe spills from the base.

Four rubber feet on the underside keep the base from moving on most work surfaces when the machine is processing heavy loads. If the feet leave spots on the counter, spray them with a spot remover and wipe with a damp sponge. If any trace of the spot remains, repeat the procedure and wipe the area with a damp sponge and nonabrasive cleaning powder.

To clean the inside of the detachable stem, slide the stem release button on the side up as far as it will go and hold it there as you run water through the stem.

**IMPORTANT:** Never store any blade or disc on the motor shaft. No blade or disc should be placed on the shaft except when the processor is about to be used.

## FOR YOUR SAFETY

Like all powerful electrical appliances, a Premier Series Food Processor should be handled with care. Follow these guidelines to protect yourself and your family from misuse that could cause injury.

Handle and store metal blades and discs carefully. Their cutting edges are very sharp.

Always place discs on flat stable surface before connecting detachable stem.

Never put blades or discs on the motor shaft until the work bowl is locked in place.

Always be sure that the blade or disc is down on motor shaft as far as it will go.

Always insert chopping blade and dough blade in the work bowl before putting ingredients in bowl.

When slicing or shredding food, always use the pusher.

Never put your fingers or spatula into feed tube.

Always wait for the blade or disc to stop spinning before you remove the pusher assembly or cover from the work bowl.

Always unplug the unit before removing food, cleaning, or putting on or taking off parts.

Always remove work bowl from base of machine before you remove chopping blade or dough blade.

Be careful to prevent the chopping blade from falling out of the work bowl when emptying the bowl. Remove it before tilting bowl, or hold it in place with your finger, a spatula or a spoon.

## TECHNICAL DATA

The motor in your food processor operates on standard line operating current. The appropriate voltage and frequency for your machine are shown on the lower housing under the base.

An automatic, temperature-controlled circuit breaker in the motor ensures complete protection against motor burnout. If the processor runs for an exceptionally long time when chopping, mixing or kneading a thick or heavy mixture in successive batches, the motor may overheat. If this happens, the processor will stop. Turn it off and wait for the motor to cool before proceeding. It will usually cool within 10 minutes. In extreme cases, cooling could take an hour.

Safety switches prevent the machine from operating when the work bowl or the cover is not locked into position. The motor stops within seconds when it has been turned off, and a fast-stop circuit stops it instantly when the pusher assembly is removed.

## LIMITED THREE-YEAR WARRANTY ON THE ENTIRE MACHINE

## FULL TEN-YEAR WARRANTY ON MOTOR

This warranty is available to consumers only. You are a consumer if you own a Cuisinart® Premier Series 9-Cup Food Processor that was purchased at retail for personal, family or household use. Except as otherwise required under applicable law, this warranty is not available to retailers or other commercial purchasers or owners.

We warrant that your Cuisinart® Premier Series 9-Cup Food Processor will be free of defects in materials and workmanship under normal home use for 3 years from the date of original purchase.

We suggest you complete and return the enclosed product registration card promptly to facilitate verification of the date of original purchase. However, return of the product registration card does not eliminate the need for the consumer to maintain the original proof of purchase in order to obtain the warranty benefits. In the event that you do not have proof of purchase date, the purchase date for purposes of this warranty will be the date of manufacture.

If your Cuisinart® Premier Series 9-Cup Food Processor should prove to be defective within the warranty period, we will repair it, or if we think necessary, replace it. To obtain warranty service, simply call our toll-free number 1-800-726-0190 for additional information from our Customer Service Representatives, or send the defective product to Customer Service at Cuisinart, 150 Milford Road, East Windsor, NJ 08520.

To facilitate the speed and accuracy of your return, please enclose \$10.00 for shipping and handling of the product.

Please pay by check or money order (California residents need only supply proof of purchase and should call 1-800-726-0190 for shipping instructions).

**NOTE:** For added protection and secure handling of any Cuisinart® product that is being returned, we recommend you use a traceable, insured delivery service. Cuisinart cannot be held responsible for in-transit damage or for packages that are not delivered to us. Lost and/or damaged products are not covered under warranty. Please be sure to include your return address, daytime phone number, description of the product defect, product model number (located on bottom of product), original date of purchase, and any other information pertinent to the product's return.

Your Cuisinart® Premier Series 9-Cup Food Processor has been manufactured to the strictest specifications and has been designed for use with the authorized accessories and replacement parts.

This warranty expressly excludes any defects or damages caused by accessories, replacement parts, or repair service other than those that have been authorized by Cuisinart.

This warranty does not cover any damage caused by accident, misuse, shipment or other ordinary household use.

This warranty excludes all incidental or consequential damages. Some states do not allow the exclusion or limitation of these damages, so they may not apply to you.

#### CALIFORNIA RESIDENTS ONLY:

California law provides that for In-Warranty Service, California residents have the option of returning a nonconforming product (A) to the store where it was purchased or (B) to another retail store which sells Cuisinart products of the same type.

The retail store shall then, at its discretion, either repair the product, refer the consumer to an independent repair facility, replace the product, or refund the purchase price less the amount directly attributable to the consumer's prior usage of the product. If the above two options do not

result in the appropriate relief to the consumer, the consumer may then take the product to an independent repair facility if service or repair can be economically accomplished. Cuisinart and not the consumer will be responsible for the reasonable cost of such service, repair, replacement, or refund for nonconforming products under warranty.

California residents may also, according to their preference, return nonconforming products directly to Cuisinart for repair, or if necessary, replacement, by calling our Consumer Service Center toll-free at 1-800-726-0190.

Cuisinart will be responsible for the cost of the repair, replacement, and shipping and handling for such products under warranty.

#### **BEFORE RETURNING YOUR CUISINART® PRODUCT**

If you are experiencing problems with your Cuisinart® product, we suggest that you call our Cuisinart® Service Center at

1-800-726-0190 before returning the product serviced. If servicing is needed, a Representative can confirm whether the product is under warranty and direct you to the nearest service location.

**Important:** If the nonconforming product is to be serviced by someone other than Cuisinart's Authorized Service Center, please remind the servicer to call our Consumer Service Center at 1-800-726-0190 to ensure that the problem is properly diagnosed, the product is serviced with the correct parts, and the product is still under warranty.

# Recipes

**Appetizers** ..... 22



**Soups** ..... 27



**Sauces and Dressings** ..... 31



**Breads** ..... 41



**Sides** ..... 54



**Entrées** ..... 57



**Pizza** ..... 61



**Desserts** ..... 62



## Recipe Notes

Preparation times are estimates and are based on the time it takes to prepare, assemble, and cook the ingredients once they have been gathered from the refrigerator and cupboard and placed on the counter.

Nutritional information is based on number of servings indicated. For recipes that produce a range of servings, they are based on the highest serving yield for that particular recipe.



# Appetizers

## Fresh Tomato and Corn Salsa

Try this salsa on grilled chicken or seafood.

Makes 2 cups

- 1 small onion, cut into 1-inch pieces (about ½ cup)**
- ¼ cup fresh cilantro**
- 1 medium jalapeño pepper, seeded, cut into 1-inch pieces**
- 3 medium vine-ripened tomatoes, cut into 1-inch pieces**
- 1 teaspoon fresh lime juice**
- ½ cup fresh or frozen corn kernels  
(frozen kernels do not need to be thawed)**
- ½ teaspoon kosher salt**

Place onion, cilantro and jalapeño in work bowl fitted with the metal blade. Process until finely chopped, about 5 seconds. Scrape work bowl. Add tomatoes and lime juice. Pulse until tomatoes are coarsely chopped, about 5 to 7 times. Add corn and salt; pulse once to just combine. Let sit for 1 hour before serving to allow flavors to develop. Serve with chips.

*Nutritional information per tablespoon:*

*Calories 5 (8% from fat) • carb. 2g • pro. 0g • fat 0g • sat. fat 0g  
• chol. 0mg • sod. 37mg • calc. 2mg • fiber 0g*

## Greek Spread

Use this spread to make a fresh vegetable sandwich on pita bread.

Makes about 2 cups

- 6 ounces lowfat cream cheese, cut into 1-inch pieces**
- 6 ounces feta cheese**
- ¼ cup red onion, cut into 1-inch pieces**
- ¼ cup green pepper, cored, cut into 1-inch pieces**
- ¼ teaspoon dried oregano**
- 2 tablespoons black olives, pitted**

In a food processor fitted with the metal blade, process cheeses until smooth, about 10 to 15 seconds. Scrape work bowl. Add remaining ingredients and process for 10 seconds. Scrape work bowl and process until well combined, about 10 to 15 seconds. Let sit, in refrigerator, for 1 hour to let flavor develop. Serve with crackers, mini pita rounds or vegetable sticks.

*Nutritional information per tablespoon:*

*Calories 28 (69% from fat) • carb. 1g • pro. 1g • fat 2g • sat. fat 1g  
• chol. 8mg • sod. 81mg • calc. 33mg • fiber 0g*

# Roasted Garlic and Red Pepper Spread

There is no such thing as too much garlic when it is roasted.

Makes 2 cups

- 1 large head of garlic (entire bulb), cloves peeled**
- ½ teaspoon extra virgin olive oil**
- 1 cup lowfat sour cream**
- 1 medium scallion, trimmed, cut into 1-inch pieces**
- 1 large roasted red pepper (from a jar)**
- ¼ teaspoon kosher salt**
- ¼ teaspoon freshly ground black pepper**

Preheat oven to 375°F. Toss the garlic cloves in the olive oil and wrap in foil. Set on middle oven rack and roast for 1 hour. Remove from oven and cool.

Insert the metal blade. Purée the cooled garlic, 20 seconds. Scrape work bowl. Add remaining ingredients and process for 10 to 15 seconds. Scrape work bowl and process until smooth, about 10 seconds longer. Let sit in refrigerator to develop flavor, about 1 hour. Serve with crudités or breadsticks.

*Nutritional information per tablespoon:*

*Calories 12 (45% from fat) • carb. 1mg • pro. 0g • fat 1g • sat. fat 0g  
• chol. 1mg • sod. 53mg • calc. 18mg • fiber 0g*

# Creamy Guacamole

Fresh flavors make this a great dip, sauce, topping, or side dish.

Makes 2 cups

- 1 small garlic clove**
- 3 ripe avocados, about 3 cups pulp**
- 2 teaspoons fresh lemon juice**
- ½ teaspoon kosher salt**
- ¼ teaspoon freshly ground black pepper**

Insert metal blade in food processor. With machine on, drop garlic clove through feed tube and chop. Scrape work bowl and add the avocado, lemon juice, salt and pepper. Pulse 15 times to achieve a chunky guacamole, or if a creamy consistency is desired process until ingredients are well blended. Serve with chips.

*Nutritional information per tablespoon:*

*Calories 27 (76% from fat) • carb. 1g • pro. 0g • fat 3g • sat. fat 0g  
• chol. 0mg • sod. 38mg • calc. 2mg • fiber 1g*

# Spinach, Feta and Artichoke Stuffed Mushrooms

For a savory side dish, use this stuffing in portobellos.

Makes 20 to 24 1½-inch stuffed mushrooms

- 1     ¾-inch slice French bread, cut into 4 pieces**
- ½     ounce Romano**
- 2     tablespoons lightly toasted pine nuts or walnuts**
- 1     can (15 ounces) artichokes, well drained,  
gently squeezed in paper toweling to remove excess moisture**
- 1     small garlic clove**
- 1     shallot, about ½ ounce**
- 5     ounces fresh spinach, tough stems removed**
- ½     teaspoon herbes de Provence**
- 2     ounces feta cheese, slightly crumbled**
- 2     ounces cream cheese (regular, not low or nonfat),  
cut into 1-inch pieces**
- 20    to 24 1½-inch white button or cremini mushrooms\***

Insert the metal blade. Place the bread in the work bowl and process for 45 seconds to make crumbs. With the machine running, drop the Romano down the feed tube, and process for 30 seconds until ground. Stop the machine, add the pine nuts, and pulse 5 times to chop coarsely. Transfer and reserve to a separate bowl. Add the artichokes to the work bowl; pulse 10 to 15 times to chop. Add to the breadcrumb mixture and set aside.

With the machine running, drop the garlic and shallot through the feed tube; process for 5 seconds to chop. Scrape down the sides of the bowl. Add the spinach, about 2 ounces at a time, and pulse 12 to 15 times to chop after each addition. Add the herbes de Provence, feta and cream cheese, processing for 20 seconds to incorporate. Add the reserved bread crumb mixture, pulsing 15 to 20 times to incorporate. Transfer to a bowl. The stuffing may be made up to 2 days ahead.

Rinse and dry the mushrooms thoroughly. Remove the stems and discard or reserve for another use.

Preheat oven to 425°F. Stuff each mushroom with a tablespoon of the spinach mixture. Arrange the stuffed mushrooms in a shallow baking dish that has been lightly coated with olive oil; do not crowd. The mushrooms may be stuffed up to 8 hours ahead. If making ahead, cover and refrigerate. Do not freeze. Bake the mushrooms in the preheated oven for 20 to 25 minutes. Allow to rest for 5 minutes before serving.

*Nutritional information per serving (1 mushroom, based on 24 mushrooms):*

*Calories 34 (53% from fat) • carb. 3g • pro. 2g • fat 2g • sat. fat 1g  
• chol. 5mg • sod. 113mg • calc. 28mg • fiber 1g*

\*Cremini mushrooms are a darker version of the white button mushroom and have a more intense flavor. When grown to large size (4 to 5 inches in diameter), they become the popular portobello mushrooms. In some markets, cremini mushrooms may be labeled Baby Bellas.

# Turkey Sausage and Sun-Dried Tomato Puff Pastry Pinwheels

Do-ahead prep makes these perfect for entertaining.

Makes 28 pinwheels

- ¼ cup toasted walnuts**
- ¾ ounce Asiago, cut into ½-inch pieces**
- 4 sun-dried tomato halves, reconstituted in ½ cup boiling water until softened, squeezed dry**
- 1 shallot (1 ounce)**
- ¼ pound Italian turkey sausage, roasted and cooled, cut into ¾-inch slices\***
- 8 ounces cream cheese, regular or lowfat, not nonfat, cut into cubes**
- 1 teaspoon basil**
- ¼ teaspoon freshly ground black pepper**
- 1 sheet frozen puff pastry, thawed for 1 hour in the refrigerator**  
**egg wash: 1 egg + 2 tablespoons water, beaten together**

Insert the metal blade. Place the walnuts in the work bowl, pulse 5 times to chop. Remove and reserve. With the machine running, drop the cheese cubes down the feed tube. Process for 30 seconds until finely chopped, remove and reserve. Put the sun-dried tomatoes in the work bowl, pulse 5 times to chop, remove and reserve.

With the machine running, drop the shallot down the feed tube and process until finely chopped, about 5 seconds. Scrape down the sides of the work bowl. Add the sausage and pulse about 3 times to roughly chop. Add the cream cheese, basil and ground pepper to the work bowl. Use the pulse to incorporate. Scrape down the sides of the work bowl. Add the reserved chopped walnuts, Asiago cheese and sun-dried tomatoes. Use the pulse to incorporate. Transfer the mixture to a small bowl.

On a lightly floured surface, roll out the sheet of puff pastry to 10 x 14 inches. Arrange the pastry on the work surface so that the long side is in front of you. Brush the top 1-inch edge of the pastry with the egg wash. Using an offset or palette spatula, spread the cream cheese mixture evenly on the puff pastry. Roll the pastry evenly, jelly-roll style, so that you roll into the egg-washed edge. Wrap in plastic wrap and refrigerate for at least 1 hour and up to 24. (The entire roll may be frozen; thaw in the refrigerator for 2 to 3 hours before continuing.) Cover and refrigerate the egg wash.

Preheat the oven to 400° F. Slice the puff pastry into 28 slices, each ½-inch thick. (If the puff pastry has not already been frozen once, you may freeze it now for baking later. Freeze the slices on a plastic wrap-lined baking sheet in a single layer. When frozen solid, transfer to a freezer bag. Double-wrap the bag to keep out freezer odors. May be frozen up to 3 weeks.) Arrange the puff pastry slices on a baking sheet about 1 inch apart. Lightly brush with the egg wash. Bake for 23 to 28 minutes, until puffed and golden. Serve hot/warm. If desired, they may be baked ahead. Bake until light golden, cool, then refrigerate until ready to serve. Reheat in a 300°F oven for about 5 minutes.

\*To roast the turkey sausage, prick the sausage several times with a fork, rub lightly with about ½ teaspoon of olive oil, then roast on a foil-lined pan at 350°F for 25 to 30 minutes, turning after 15 minutes.

*Nutritional information per pinwheel:*

*Calories 90 (64% from fat) • carb. 5g • pro. 3g • fat 6g • sat. fat 2g  
• chol. 15mg • sod. 114mg • calc. 22mg • fiber 0g*

# Hummus

This popular Middle Eastern sauce may be served with the traditional pita wedges or may be used as a dip for fresh vegetable crudités. For something a little different, make the original recipe, and then use half to make one of the variations.

Makes 2½ cups

- ¼ cup fresh flat parsley leaves
- 2 strips lemon zest, ½ x 2 inches, bitter white scraped off
- ½ teaspoon kosher salt
- 2 small garlic cloves
- 2 cans (15.5 ounces each) chickpeas, drained, rinsed and drained again
- 3 tablespoons tahini paste
- 2 tablespoons fresh lemon juice
- 5 tablespoons water
- 1½ teaspoons ground cumin
- 1½ tablespoons extra virgin olive oil

Insert the metal blade. Use the pulse to chop the parsley, 10 to 15 times. Remove and reserve. Chop the lemon zest with the kosher salt using the pulse, 10 times. With the machine running, drop the garlic down the feed tube, and process 10 seconds to chop. Add the drained chickpeas, tahini, lemon juice, water, and cumin to the work bowl, processing 60 seconds to combine. Scrape down the sides and bottom of the work bowl. With the machine running, add the olive oil in a slow steady stream, and process until the hummus is smooth and creamy, about 3 minutes. Add half the chopped parsley; pulse to incorporate, 5 to 10 times. Allow the hummus to rest for 30 minutes before serving to allow the flavors to blend. Serve in a shallow bowl, sprinkled with the remaining chopped parsley. If desired, drizzle with extra virgin olive oil.

*Nutritional information per tablespoon:*

*Calories 37 (29% from fat) • pro. 1g • carb. 5g • fat 1g • sat. fat 0g  
• chol. 0mg • sod. 36mg • calc. 17mg • fiber 1g*

**Roasted Shallot and Herb Hummus:** Toss 6 ounces of peeled and trimmed shallots in ½ teaspoon extra virgin olive oil and wrap in heavy-duty foil; roast in a 400°F oven for 60 minutes. Allow to cool. Make hummus according to the above recipe, adding the cooled roasted shallots along with 2 teaspoons herbes de Provence when processing the chickpeas. Makes about 2¼ cups.

**Roasted Red Pepper Hummus:** Make hummus according to the above recipe; add 3 roasted red peppers when adding the chickpeas. Makes about 2½ cups.

**Roasted Garlic Hummus:** Toss 12 to 15 cloves of garlic in ½ teaspoon of extra virgin olive oil and wrap in heavy-duty foil; roast in a 400°F oven for 60 minutes. Allow to cool. Make hummus according to the above recipe; add the cooled roasted garlic when adding the chickpeas. Makes about 2 cups.

# Soups



## Gazpacho

Always served well chilled, this summertime favorite has its origins in the Andalusian region of Spain.

Makes 4 servings, 8 ounces each

- 1 garlic clove**
- 1 small jalapeño pepper, seeded, cut into 1-inch pieces**
- 3 small scallions, trimmed, cut into 1-inch pieces**
- 1 small green bell pepper, about 6 ounces, cored, seeded, cut into 1-inch pieces**
- 1 small cucumber, about 6 ounces, peeled, cut in half lengthwise, seeds removed**
- ¼ cup fresh parsley**
- 2 medium tomatoes, about 10 ounces, cored, cut into 1-inch pieces**
- 2 teaspoons fresh lime juice**
- ¾ teaspoon kosher salt**
- ¼ teaspoon freshly ground black pepper**
- ¼ teaspoon hot sauce**
- 1¼ cups low sodium tomato or vegetable juice**

Insert metal blade and turn machine on. Drop garlic and jalapeño down feed tube and process until finely chopped. Scrape bowl. Add scallions to the work bowl and pulse to chop roughly. Add peppers, cucumber and parsley and pulse again to chop roughly, about 6 pulses. Add tomatoes, lime juice, salt, pepper, and hot sauce and pulse 8 to 10 times so that vegetables are evenly chopped. Transfer vegetables to a large mixing bowl and mix in tomato juice. Taste and adjust seasoning accordingly.

*Nutritional information per serving:*

*Calories 39 (7% from fat) • carb. 8g • pro. 2g • fat 0g • sat. fat 0g  
• chol. 0mg • sod. 503mg • calc. 31mg • fiber 2g*

# Butternut Squash Soup with Leeks

Makes 5 servings, eight ounces each

- 2 garlic cloves**
- 1 medium or 2 small leeks, about 5 ounces, rinsed well and cut into 1-inch pieces**
- 1 teaspoon extra virgin olive oil**
- 2 pounds butternut squash**
- ½ teaspoon kosher salt**
- ¼ teaspoon freshly ground pepper**
- ½ cup dry white wine**
- 3 cups low sodium chicken broth**
- ¼ teaspoon ground nutmeg**
- ½ teaspoon fresh lemon juice**
- ½ cup heavy cream (optional)**

Insert the metal blade. With the machine running, drop the garlic through the feed tube and process to finely chop. Scrape the work bowl. Add the leeks and pulse to chop, about 10 pulses.

Place 6-quart stockpot over medium heat and add the olive oil. When the olive oil is hot, stir in the chopped leeks and garlic. Sweat the vegetables over medium low heat so that they become soft. Stir occasionally so that they do not pick up any color.

While the leeks are cooking, replace the chopping blade with the slicing disc assembly. Peel and seed the squash; cut to fit the feed tube. Slice the squash.

Add the sliced squash into the stockpot with the leeks and garlic; stir well. Add the salt and pepper. Cook for an additional 5 minutes.

Add the wine to the pot. Bring to a simmer and let the wine reduce by half. Add the chicken broth and nutmeg. Bring soup to a low boil. Reduce heat and let simmer until squash is very soft and is easily pierced with a knife, about 20 minutes.

Strain the solids from the cooking liquid, reserving the cooking liquid. Transfer half of the cooking liquid to a clean pot and reserve. Insert the metal blade. In two batches, add the solids to the food processor and process to purée, 2 to 3 minutes. Scrape the work bowl to insure the mixture is homogenous. Return the puréed solids to the cooking liquid and stir to incorporate. Add the lemon juice. Stir in reserved cooking liquid to obtain desired consistency. Taste and adjust seasoning. If using the heavy cream, stir in last and bring to a simmer.

*Nutritional information per serving:*

*Calories 157 (11% from fat) • carb. 29g • pro. 5g • fat 2g • sat. fat 0g  
• chol. 0mg • sod. 292mg • calc. 119mg • fiber 4g*

# Caramelized Five Onion Soup

A twist on traditional French onion soup.

Makes 6 servings, eight ounces each

- 1 **garlic clove**
- 2 **shallots (2 ounces total)**
- 3 **Spanish onions (1½ pounds total), cut in half vertically**
- 2 **red onions (1 pound total), cut in half vertically**
- 2 **leeks, about 1 inch in diameter, trimmed and well cleaned\*, cut into 2-inch lengths**
- 2 **tablespoons unsalted butter**
- 2 **tablespoons extra virgin olive oil**
- 1½ **teaspoons granulated sugar**
- 1 **teaspoon kosher or sea salt**
- 3 **tablespoons unbleached, all-purpose flour**
- 5 **cups vegetable stock or broth (chicken or beef may also be used)**
- ½ **teaspoon freshly ground black pepper**
- 2 **ounces Asiago, cut into ½-inch cubes**
- 2 **ounces imported Gruyère**
- 2 **ounces Jarlsberg (reduced-fat may be used)**
- 6 **green onions, washed, dried and trimmed, cut into 1-inch pieces**
- 6 **slices French bread, about ½-inch thick, brushed with extra virgin olive oil and rubbed with a clove of garlic, toasted in a 400°F oven on a baking sheet until golden and crispy**

Insert the metal blade, and with the machine running, drop the garlic and shallot through the feed tube, and process for 5 seconds to chop. Insert the slicing disc. Using medium pressure, slice the onions. Remove and reserve. Place the leeks in the feed tube, snugly but not too tightly. Use medium pressure to slice. Transfer to the bowl with all the other onions.

Heat the butter and olive oil in a 5-quart stockpot over medium-high heat. Add the garlic and onions; stir to coat with the butter and olive oil. Lower the heat, cover loosely, and allow the onions to cook over low heat for 10 to 12 minutes to soften. Add the sugar and the salt, stir to combine, and cook the onion mixture over low heat for 25 to 35 minutes to caramelize, stirring every 4 or 5 minutes. The onions should become the color of toffee. Sprinkle with the flour. Cook for 4 minutes, stirring. While stirring, add the stock, and bring to a boil. Reduce the heat and simmer, loosely covered, for 30 minutes. Add the pepper. Taste and adjust seasonings.

While the soup is cooking, insert the metal blade in the clean, dry work bowl. With the machine running drop the Asiago through the feed tube to chop, about 20 seconds; leave in the work bowl. Insert the shredding disc. Use medium pressure to shred the Jarlsberg and Gruyère. Remove and reserve. Insert the metal blade, pulse to chop the green onions, about 10 times.

Serve the soup in warmed bowls topped with a slice of the toasted French bread, a

sprinkling of the cheeses, and topped with the chopped green onion. If desired, the bowls may be placed under a broiler or in a hot oven to melt the cheeses; if you do this, be sure to use ovenproof bowls.

\*Leeks are grown in very sandy soil, and must be well cleaned, or the grit will ruin your soup. Trim the roots from the leeks, and then trim and discard the leaves, about 1 inch above the white. Wash well and dry. The leeks used in this recipe yielded about a 4-inch piece of leek. Not all leeks have the same amount of usable white, so you will have to adjust the number of leeks accordingly. The leek tops are too tough to use in cooking, but can be washed well and used to flavor stocks.

*Nutritional information per serving:*

*Calories 400 (39% from fat) • carb. 46g • pro. 14g • fat 18g • sat. fat 8g  
• chol. 35mg • sod. 1297mg • calc. 389mg • fiber 3g*

## **Vegetarian Potato and Split Pea Soup**

This hearty soup has only three fat grams per serving.

Makes 6 servings, nine ounces each

- 1 carrot, peeled, cut to fit feed tube vertically**
- 1 celery rib, peeled, cut to fit feed tube vertically**
- 1 onion, cut in half**
- 1½ tablespoons unsalted butter**
- 1 garlic clove**
- 5 cups vegetable broth**
- 1 small potato (about 6 to 7 ounces)**
- ¾ pound split green peas, rinsed and sorted**
- ¼ teaspoon kosher salt**
- ¼ teaspoon freshly ground black pepper**

Insert the 4mm slicing disc. Slice the carrot, celery and onion using medium pressure; reserve.

Melt butter in a 3¾-quart saucepan over medium heat. Add carrot, celery, onion and garlic. Cook until soft, about 10 to 15 minutes. Add broth; cover and bring to a boil over medium-high heat. Peel potato and cut into 1-inch pieces. Add potato and split peas to saucepan. Reduce heat to low and simmer, partially covered, until peas and potatoes are tender, about 30 minutes. Remove from heat and cool for 10 minutes. Drain liquid from vegetables, being sure to reserve liquid in a large saucepan.

Insert metal blade. Process half of vegetables until smooth, about 15 to 20 seconds. Return to saucepan with liquid and repeat with remaining vegetables. Warm over low heat. Season with salt and pepper. Taste and adjust accordingly.

*Nutritional information per serving:*

*Calories 116 (23% from fat) • carb. 19g • pro. 4g • fat 3g • sat. fat 2g  
• chol. 8mg • sod. 260mg • calc. 29mg • fiber 4g*

# Sauces and Dressings



## Basic Mayonnaise

(The American Egg Board recommends using the freshest eggs and then heating them to kill salmonella bacteria. This recipe uses a procedure suggested by cookbook author and food sleuth Shirley Corriher for heating the eggs to sanitize them. The results are definitely worth the effort. Proper refrigeration and storage is necessary.)

Makes 1 cup

- 1 large egg**
- 1 large egg yolk**
- 1½ teaspoons fresh lemon juice**
- 1½ teaspoons wine vinegar**
- 1 tablespoon water**
- ¼ teaspoon granulated sugar**
- ¼ teaspoon unbleached, all-purpose flour**
- 2 teaspoons dry mustard**
- ½ teaspoon kosher salt**
- pinch cayenne**
- 2 tablespoons extra virgin olive oil**
- ¾ cup vegetable oil (canola, soya, etc.)**

Insert the metal blade. Process the egg, egg yolk, lemon juice, vinegar, water, sugar and flour until smooth, about 20 seconds. Transfer the egg mixture to a small (7- or 8-inch) nonstick skillet, and heat over very low heat while gently stirring and scraping the bottom of the pan with a spatula. When the mixture begins to thicken and resemble a custard sauce, remove from the heat while still stirring and set in a pan of ice and water to stop the cooking. Stir until the egg mixture is cooled, let rest for 5 minutes. Wash the work bowl, metal blade and lid in hot soapy water and dry thoroughly.

Insert the metal blade. Process the cooled egg mixture with the dry mustard, salt, and cayenne until blended, about 1 minute. Scrape the work bowl. With the machine running, add the olive oil very, very slowly, taking about 1 minute to add the entire 2 tablespoons. Scrape the work bowl. With the machine running, add the vegetable oil to the small pusher, one-quarter cup at a time, and allow the oil to drip slowly into the emulsion. The mayonnaise will thicken as the oil is added. Taste and adjust seasonings as necessary. Remove to a container, cover and keep refrigerated. Keeps 3 to 4 days refrigerated.

*Nutritional information per tablespoon:*

*Calories 115 (97% from fat) • carb. 0g • pro. 1g • fat 13g • sat. fat 2g  
• chol. 26mg • sod. 78mg • calc. 3mg • fiber 0g*

# Tartar Sauce

A little lower in fat than most, this tartar sauce is good not only with fish and shellfish, but also with steamed fresh vegetables.

Makes 1½ cups / 24 tablespoons

- 1½ ounces shallots or green onions, trimmed and cut into 1-inch pieces**
- 2 ounces drained sweet gherkin pickles**
- 3 tablespoons fresh flat parsley leaves**
- 1½ tablespoons fresh dill weed**
- 2¼ teaspoons Dijon-style mustard**
- ¾ teaspoon fresh thyme leaves**
- 2½ tablespoons drained capers**
- ¾ cup Basic Mayonnaise (see previous recipe)**
- 1 cup nonfat plain yogurt, drained overnight to remove the whey (yield=½ cup)**
- ¼ teaspoon freshly ground black pepper**

Insert the metal blade. Use the pulse to chop the shallots, gherkins and parsley, 15 quick pulses. Add the dill, mustard, thyme, and capers; pulse 5 times to chop. Add the mayonnaise, drained yogurt and black pepper; pulse to combine, 5 times; do not overprocess.

Refrigerate until ready to use.

*Nutritional information per tablespoon:*

*Calories 68 (83% from fat) • carb. 2g • pro. 1g • fat 6g • sat. fat 1g  
• chol. 13mg • sod. 101mg • calc. 16mg • fiber 0g*

# Pesto

Our Pesto is lower in fat than traditional pestos, and just as flavorful.

Makes ¾ cup

- 1 small garlic clove**
- 1 ounce Reggiano Parmigiano, cut into ½-inch pieces**
- 4 cups packed fresh basil leaves, washed and dried**
- 3 tablespoons lightly toasted pine nuts or walnuts**
- ¼ teaspoon plus pinch salt**
- 5 tablespoons extra virgin olive oil**

Insert the metal blade. With the machine running, drop the cheese down the feed tube and process to finely chop. Chop the garlic clove in the same fashion. Scrape down the sides of the work bowl. Add the basil, pine nuts, and salt to the work bowl. Pulse to chop, 20 to 30 times. Scrape down the sides of the work bowl.

With the machine running, add the olive oil in a slow drizzle. Let rest for about 30 minutes before using to allow the flavors to blend. Refrigerate to store, with a layer of olive oil poured over the top to prevent discoloration. Keeps 5 days in the refrigerator, or may be frozen.

*Nutritional information per tablespoon:*

*Calories 78 (87% from fat) • carb. 1g • pro. 2g • fat 8g • sat. fat 1g  
• chol. 2mg • sod. 98mg • calc. 49mg • fiber 1g*

## Sun-Dried Tomato Tapenade

For a quick hors d'oeuvre, split a wheel of chilled Brie, spread the bottom half with a ¼-inch thick layer of Sun-Dried Tomato Tapenade, replace the top and allow to sit at room temperature for 45 minutes to soften, then serve with your favorite crackers or French bread.

Makes 1 cup / 16 tablespoons

- 2 ounces sun-dried tomato halves**
- ½ cup water**
- ¾ ounce Reggiano Parmigiano, cut into ½-inch pieces**
- 1 garlic clove**
- ½ ounce shallot**
- 1½ tablespoons fresh flat parsley leaves**
- 3 tablespoons toasted walnuts**
- 2 teaspoons white wine vinegar**
- ½ tablespoon dried basil**
- ½ teaspoon rosemary**
- ¼ teaspoon freshly ground black pepper**
- 2 tablespoons extra virgin olive oil**

Combine the sun-dried tomatoes and water in a small saucepan. Bring to a boil, then turn off the heat. Let sit until cool, drain well, pressing gently on the plumped tomatoes to remove as much of the excess liquid as possible. Reserve.

Insert the metal blade. With the machine running, drop the cheese down the feed tube. Process to chop, 10 seconds. Remove and reserve. With the machine running, drop the garlic and shallot down the feed tube, process 5 seconds to chop. Add the reserved tomatoes, parsley, and walnuts, pulse to chop, 10 times. Add the vinegar, basil, rosemary, and black pepper, pulse to combine, 5 times. With the machine running, add the olive oil in a steady stream, about 30 seconds. Add the reserved cheese and pulse to combine, 5 times. Allow to rest for 30 minutes before using for the flavors to blend. Transfer to a glass jar with a plastic lid and refrigerate until ready to use. Keeps 2 weeks in the refrigerator.

*Nutritional information per tablespoon:*

*Calories 33 (60% from fat) • carb. 2g • pro. 1g • fat 2g • sat. fat 1g  
• chol. 1mg • sod. 95mg • calc. 23mg • fiber 1g*

# Simple Tomato Sauce

A simple marinara sauce for pasta, or when reduced, a tasty topping for homemade pizzas.

Makes 3 cups tomato sauce for pasta / 1¾ cups tomato sauce for pizza

- 1 small onion (4 ounces), cut into 1-inch pieces**
- 4 garlic cloves**
- ¾ teaspoon dried oregano**
- 1 teaspoon extra virgin olive oil**
- 1 can (28 ounces) plum tomatoes, with juices**
- 2 sprigs fresh basil (10-12 large leaves)**
- 3 tablespoons dry white wine or vermouth**
- ½ teaspoon kosher salt**
- ¼ teaspoon freshly ground black pepper**
- ¼ to ¾ teaspoon crushed red pepper flakes (optional, to taste, for a spicier sauce)**

Insert the metal blade. Pulse to chop the onion and garlic with the oregano, about 10 times. Heat the oil over medium heat in a 2¾-quart saucepan; add the onion, garlic, and oregano. Cook, stirring for 2 to 3 minutes, until the onions begin to soften and the oregano becomes fragrant. Add the canned tomatoes with their juices, basil sprigs, wine and salt. Bring to the boil, then reduce the heat to low, cover loosely and simmer for 50 to 60 minutes. Turn off the heat and let cool in the pan for 10 minutes. Stir in the black pepper and red pepper flakes if using.

Using the metal blade, pulse the sauce 15 times for a rustic, chunky sauce, or process for 2 minutes for a smooth sauce. The sauce is now ready to use for pasta. If you want a sauce for pizza, return the sauce to the pan. Simmer, uncovered, for 40 to 50 minutes to reduce, stirring now and then. Transfer the reduced sauce to a bowl to cool before using as a pizza topping. The sauce freezes well.

*Nutritional information per half-cup, tomato sauce:*

*Calories 50 (15 % from fat) • carb. 8g • pro. 1g • fat 1g • sat. fat 0g  
• chol. 0mg • sod. 482mg • calc. 31mg • fiber 1g*

*Nutritional information per quarter-cup, reduced for pizza sauce:*

*Calories 25 (15% from fat) • carb. 4g • pro. 1g • fat 0g • sat. fat 0g  
• chol. 0mg • sod. 241mg • calc. 16mg • fiber 1g*

# Roasted Red Pepper Sauce

A simple, flavorful, and healthy sauce to complement chicken, seafood, and vegetables.

Makes 1¾ cup

- cooking spray**
- 4 large red peppers, about 2-2½ pounds**
- 3 garlic cloves**
- 1 medium onion, cut evenly into eight pieces**

- 1      teaspoon extra virgin olive oil**
- ¼      cup dry white wine**
- ½      cup low-sodium chicken broth**
- ¼      teaspoon kosher salt**
- ¼      teaspoon freshly ground black pepper**
- ¼      teaspoon fresh lemon juice**

Preheat oven to 400°F.

Coat a baking sheet lightly with cooking spray and place red peppers on sheet.

Roast peppers in the oven for about 1 hour, turning the peppers halfway through the roasting time. The skins of the peppers should be evenly browned.

Place peppers in a bowl and cover the bowl tightly with plastic wrap. Reserve to cool, at least one hour.

Once peppers are completely cool, remove and discard all skins and seeds. Roughly chop the peppers.

Once peppers are chopped, insert the metal blade to the food processor. With the machine running, drop the garlic through the feed tube to finely chop. Add the onions to the work bowl and pulse to evenly chop, about 10 pulses.

Place a sauté pan over medium heat and add the olive oil. When the olive oil is hot, add the chopped onions and garlic. Sweat vegetables until they are soft, about 5 minutes. Stir in the chopped peppers until heated through. Add the wine and bring to a simmer and reduce by half. Add the chicken broth, salt and pepper. Allow sauce to simmer for about 5 minutes. Transfer contents of pan to work bowl. Process until sauce is homogenous.

Remove sauce from work bowl and add the lemon juice. Taste and adjust seasoning if necessary.

*Nutritional information per tablespoon:*

*Calories 12 (17% from fat) • carb. 2g • pro. 0g • fat 0g • sat. fat 0g  
• chol. 0mg • sod. 35mg • calc. 3mg • fiber 1g*

## **Chocolate Sauce with Variations**

This Cuisinart version replaces cream with skim milk, cutting the fat nearly in half.

Makes 1½ cups

- 6      ounces good quality bittersweet or semisweet chocolate (Lindt, Callebaut, Ghirardelli), broken into 1-inch pieces**
- 4      ounces good quality milk chocolate (Lindt, Callebaut, Ghirardelli), broken into 1-inch pieces**
- 2      tablespoons superfine or bar sugar (optional)**
- ½      cup skim milk, heated until it is just bubbling around the edges**
- 1      teaspoon pure vanilla extract**

Insert the metal blade. Add the chocolates to the work bowl. Using long pulses, pulse about 15 to 20 times. If using sugar, add and process for 10 seconds. With the machine

running, pour the hot milk slowly and carefully down the feed tube, process until the chocolate is melted and smooth, 1 minute. Add the vanilla, process to combine, 10 seconds.

*Nutritional information per tablespoon:*

*Calories 62 (57% from fat) • carb. 7g • pro. 1g • fat 5g • sat. fat 2g  
• chol. 1mg • sod. 6mg • calc. 15mg • fiber 1g*

**Amaretto Almond Chocolate Sauce:** Before making the chocolate sauce, use the pulse to chop  $\frac{1}{4}$  cup of toasted slivered almonds, remove and reserve. Make the sauce as per instructions, but omit the vanilla, and add 1 tablespoon amaretto and the chopped toasted almonds.

**Mocha Latte Sauce:** Make the chocolate sauce as per instructions, adding  $\frac{1}{2}$  tablespoons instant espresso and increasing the superfine sugar by  $\frac{1}{2}$  tablespoon. Along with the vanilla, add 1 tablespoon Kahlúa and 1 tablespoon heavy cream.

**Chocolate Mint Sauce:** Make the chocolate sauce as per instructions, omitting the vanilla and adding 1 tablespoons peppermint schnapps or 2 teaspoons peppermint extract.

## Asian Slaw with Peanut Dressing

Add cooked pasta and turn this salad into a meal.

Makes 8 servings, one cup each

### Dressing:

- $\frac{1}{2}$  cup toasted unsalted peanuts
- 2 garlic cloves
- 6 slices of fresh ginger, peeled, each about the size of a quarter
- 4 tablespoons natural style peanut butter
- $\frac{1}{3}$  cup plus 1 tablespoon rice vinegar
- 1 tablespoon granulated sugar
- 2 tablespoons + 1 teaspoon hoisin sauce
- 2 teaspoons sesame oil
- 2 teaspoons low-sodium tamari or soy sauce
- $2\frac{1}{2}$  tablespoons vegetable oil

### Salad:

- 4 ounces red radishes, washed, ends cut flat
- 4 ounces carrots, peeled and trimmed to fit the feed tube horizontally
- 1 broccoli spear, washed, flowerets trimmed and reserved, stem peeled
- 3 green onions, trimmed, cut into 4-inch lengths, including tasty green tops
- 1 red bell pepper, stemmed, seeded and cut into  $1\frac{1}{2}$  x 3-inch pieces

- 1 yellow bell pepper, stemmed, seeded and cut into 1½ x 3-inch pieces**
- 8 ounces Napa cabbage, washed and cut into 3-inch lengths**
- 6 ounces bok choy, washed and cut into 3-inch lengths (include leaves if pretty and tender)**
- 4 ounces snow peas, trimmed**

Insert the metal blade. Pulse to chop the peanuts, about 10 times. Remove and reserve. With the machine running, drop the garlic and ginger down the feed tube to chop. Scrape the work bowl; process 5 seconds longer. Add the peanut butter, rice vinegar, sugar, hoisin sauce, sesame oil, and tamari. Process until smooth, about 10 seconds. Scrape the work bowl. With the machine running, add the oil in a steady stream through the small feed tube. Process until emulsified, about 10 to 15 seconds. Remove and reserve. The dressing may be made up to several days ahead. Cover well and refrigerate. Allow to sit for 30 minutes at room temperature before using.

Clean the work bowl. Insert the shredding disc. Arrange the radishes in the large feed tube, cut side down, and shred. Arrange the carrots horizontally in the large feed tube and shred. Insert the trimmed and broccoli stem in the small feed tube and shred. Transfer the shredded vegetables to a large bowl.

Insert the slicing disc. Arrange the green onions in the small feed tube and slice. Arrange the peppers in the large feed tube, cut side down and slice. Arrange the Napa cabbage in the feed tube, cut side down and slice. Arrange the bok choy in the feed tube and slice. Transfer the sliced vegetables to the bowl with the other vegetables. Add the snow peas and toss the vegetables to combine. Pour the dressing over the vegetables and toss to coat well. Transfer to a serving bowl and garnish with the reserved chopped peanuts.

Note: You may turn this into an Asian pasta salad by doubling the dressing ingredients and adding cooked pasta (8 ounces dry, cooked according to package directions).

*Nutritional information per serving:*

*Calories 201 (59% from fat) • carb. 16g • pro. 7g • fat 14g • sat. fat 2g  
• chol. 0mg • sod. 172mg • calc. 76mg • fiber 4g*

## **Shredded Carrot Salad with Honey-Ginger Dressing**

Healthy, nutritious and delicious.

Makes 12 one-half-cup servings, ½ cup each

- ⅔ cup walnut halves, shells removed**
- 1½ pounds carrots, peeled, cut into 2-inch pieces**
- ¾ ounce fresh gingerroot, peeled, cut into ½-inch pieces**
- 1 cup plain nonfat yogurt, drained\***
- ⅓ cup fresh mint leaves**
- 1½ tablespoons honey**
- ⅔ cup golden raisins**

Preheat oven to 350°F. Place walnut halves in a baking pan and toast until golden brown and fragrant, about 8 to 10 minutes. Allow to cool slightly. Insert metal blade in food processor and pulse to chop nuts coarsely, about 5 to 6 times. Reserve.

Insert shredding disc. Place carrots in large feed tube horizontally and shred. Transfer to a large mixing bowl. Insert metal blade. Process gingerroot until finely chopped, about 5 to 10 seconds. Scrape bowl. Add yogurt, mint and honey. Process to combine, about 10 seconds. Scrape work bowl and process an additional 5 seconds. Add to shredded carrots and combine. Add raisins and gently mix. Serve chilled on a bed of lettuce.

\*To drain yogurt: Line a sieve with a double layer of cheesecloth or a paper coffee filter and set over a bowl. Place yogurt in sieve, cover and refrigerate at least 8 hours or overnight. You may need to drain water from bowl occasionally. Refrigerate thickened yogurt in an airtight container for up to one week.

*Nutritional information per serving:*

*Calories 76 (13% from fat) • carb. 16g • pro. 2g • fat 1g • sat. fat 0g  
• chol. 0mg • sod. 51mg • calc. 56mg • fiber 2g*

## Capered Tuna Spread

Use for sandwiches, or as an hors d'oeuvre spread served with crusty bread, chopped imported olives and sun-dried tomatoes.

Makes 1 cup / 2 to 4 servings

- 2      tablespoons loosely packed fresh flat parsley leaves**
- 1      4-inch rib of celery, cut into ½-inch pieces**
- 1      ounce shallots**
- ½     tablespoon drained capers, rinsed and drained again**
- 2      teaspoons Dijon-style mustard (regular or grainy)**
- 1      can (6 ounces) water-packed white albacore tuna, well drained**
- 3      tablespoons mayonnaise**
- ¼     teaspoon freshly ground black pepper**

Insert the metal blade, put the parsley in the work bowl and pulse to chop, about 5 times. Add the celery to the work bowl, rough chop using the pulse, about 5 times. With the machine running, drop the shallots through the feed tube, process 5 seconds to chop. Add the capers and mustard, pulsing to chop finely, about 10 times. Add the tuna; pulse to chop, about 10 times. Add the mayonnaise and black pepper. Use the pulse to combine, about 5 times, do not over process. Transfer to a bowl, cover and chill for 30 minutes before serving to allow the flavors to develop. Taste and adjust seasonings as necessary. (Note: capers can be quite salty, so there is no additional salt in this recipe. If your palate dictates more salt, add kosher or sea salt to taste.)

*Nutritional information per serving (based on 4 servings):*

*Calories 130 (62% from fat) • carb. 2g • pro. 10g • fat 9g • sat. fat 2g  
• chol. 26mg • sod. 349mg • calc. 11mg • fiber 0g*

# Lemony Honey Dijon Vinaigrette

Try this dressing on a salad with sliced grilled chicken.

Makes 1½ cups

- 2 strips lemon peel, each 2 inches x ½ inch**
- ¾ teaspoon kosher or sea salt**
- 2 shallots, ½ ounce each**
- 3 tablespoons fresh lemon juice**
- 2 tablespoons white wine vinegar**
- 2 tablespoons honey**
- 2 teaspoons Dijon-style mustard**
- ½ teaspoon freshly ground black pepper**
- 3 tablespoons vegetable oil**
- ½ cup plus 2 tablespoons extra virgin olive oil**

Insert the metal blade. Chop the lemon zest with the salt using the pulse, 20 to 30 times. With the machine running, drop the shallots down the small feed tube; process for 5 seconds to chop. Add the lemon juice, wine vinegar, honey, mustard, and black pepper to the work bowl; process for 5 seconds to blend. Combine the oils. With the machine running, pour the oils into the small pusher and allow to drip through the hole in a small steady stream. Transfer to a jar and allow to sit for at least 30 minutes before using, to allow the flavors to blend. May be kept up to 2 weeks in the refrigerator. Allow the dressing to come to room temperature before using. Process again, using the metal blade, if the dressing has separated.

\*Remove the peel from the lemon with a vegetable peeler, then take a sharp paring knife and carefully scrape away the bitter white pith from the underside of the peel.

*Nutritional information per tablespoon:*

*Calories 72 (89% from fat) • carb. 2g • pro. 0g • fat 7g • sat. fat 1g  
• chol. 0mg • sod. 83mg • calc. 1mg • fiber 0g*

# Creamy Chèvre and Peppercorn Dressing

Creamy and tangy, perfect for crispy romaine.

Makes 1¾ cups (28 tablespoons)

- 1½ ounces shallots**
- 1 tablespoon plus 1 teaspoon drained green peppercorns, rinsed and drained again**
- 6 ounces chèvre**
- ⅓ cup lowfat sour cream**
- 1½ tablespoons fresh lemon juice**
- 1½ tablespoons white wine vinegar**
- 1½ tablespoons water**
- ⅓ cup extra virgin olive oil**

Insert the metal blade. With the machine running, drop the shallots down the small feed tube; process 5 seconds to chop. Add the drained green peppercorns, chop 10 seconds. Remove and reserve. Process the chèvre, sour cream, lemon juice, white wine vinegar and water, until smooth, 30 seconds. Scrape the work bowl. Return the shallot and peppercorn mixture to the work bowl, add the salt. With the machine running, add the olive oil through the hole in the small pusher, processing until completely incorporated and emulsified. Let sit for 30 minutes before using, to allow the flavors to blend. The dressing will keep for a week in the refrigerator.

*Nutritional information per tablespoon:*

*Calories 48 (76% from fat) • carb. 2g • pro. 1g • fat 4g • sat. fat 1g  
• chol. 4mg • sod. 37mg • calc. 15mg • fiber 0g*

## Herbed Balsamic Vinaigrette

Drizzle over sliced summer tomatoes for a quick and easy salad.

Makes about 1 cup

- 1 large garlic clove**
- ¼ cup fresh flat parsley leaves**
- 1 tablespoons dried basil**
- 1 teaspoon dried oregano**
- ½ teaspoon kosher or sea salt**
- ½ teaspoon freshly ground black pepper**
- 2 teaspoons Dijon-style mustard**
- 6 tablespoons balsamic vinegar**
- ⅔ cup extra virgin olive oil**

Insert the metal blade. With the machine running, drop the garlic down the small feed tube, process 5 seconds to chop. Add the fresh parsley, dried basil and oregano, salt, pepper, mustard and vinegar, processing 10 seconds to blend. With the machine running, add the olive oil one third cup at a time through the hole in the small feed tube pusher. Process 1 minute longer until totally emulsified.

Adjust seasonings to taste. Allow the dressing to rest for 30 minutes before using to allow the flavors to blend. Refrigerate unused portions, bring to room temperature (30 minutes) before using and reprocess to emulsify using the metal blade if necessary.

*Nutritional information per tablespoon:*

*Calories 86 (94% from fat) • carb. 1g • pro. 0g • fat 9g • sat. fat 1g  
• chol. 0mg • sod. 89mg • calc. 8mg • fiber 0g*

# Breads

## Challah Braid

If you have leftovers, our Challah Braid slices make the best French toast.

Makes 18 servings (1½-pound loaf)

- 3      tablespoons granulated sugar, divided**
- 1      package active dry yeast**
- ¼     cup warm water (105-115°F)**
- ¾     cups unbleached, all-purpose flour**
- 1½    teaspoons table salt**
- ½     cup cold water**
- ⅓     cup unsalted butter, melted**
- 1      large egg**
- egg glaze (1 large egg and 1 tablespoon water)**
- vegetable oil cooking spray**

In a 2-cup liquid measure, dissolve 2 teaspoons sugar and yeast in warm water. Let stand until foamy, about 5 minutes.

Insert the dough blade in the work bowl and add flour, remaining sugar and salt. Pulse to combine, about 2 to 3 times.

Add cold water, melted butter and egg to yeast mixture. With machine running, add liquid through small feed tube in a steady stream as fast as the flour absorbs it. Once dough forms a ball continue processing for 45 seconds to knead dough. Place dough in a floured plastic food storage bag and seal. Let rise in a warm place until doubled in size, about 1 to 1½ hours.

Place dough on a lightly floured surface and punch down. Divide dough into 3 equal pieces. Use your hands to roll each piece into a cylinder about 1½ x 14 inches. Place the cylinders side by side on a baking sheet coated with vegetable oil cooking spray. Braid loosely from one end. Gently pull and taper each end to a point, then pinch and tuck under loaf. Cover with plastic wrap coated with vegetable oil cooking spray and let rise until doubled in size, about 45 minutes. Preheat oven to 375°F for 15 minutes before baking.

Prepare egg glaze by combining egg with water; brush over braid. Bake in lower third of preheated oven for 20 minutes. Lower temperature to 350°F and bake until loaf is browned and sounds hollow when tapped, about 10 minutes. Cool on wire rack.

*Nutritional information serving:*

*Calories 119 (29% from fat) • carb. 18g • pro. 3g • fat 4g • sat. fat 2g  
• chol. 32mg • sod. 202mg • calc. 4mg • fiber 0g*

# Pecan Sticky Buns

Our Pecan Sticky Buns are so good it's hard to eat just one.

Makes 9 servings

## Sweet Dough:

- 1 package active dry yeast
- ¼ cup granulated sugar, divided
- ¼ cup warm water (105-115°F)
- 2½ cups unbleached, all-purpose flour
- ¼ cup unsalted butter, in 1-inch pieces
- ½ teaspoon table salt
- ⅓ cup nonfat milk
- 1 large egg

## Topping:

- ½ cup pecans
- ¼ cup granulated sugar
- ½ teaspoon ground cinnamon
- 1 tablespoon unsalted butter, softened
- ⅓ cup raisins
- ¼ cup unsalted butter, melted
- ⅓ cup firmly packed light brown sugar
- vegetable oil cooking spray

## To make dough:

In a 2-cup liquid measure dissolve yeast and 1 teaspoon sugar in warm water. Let sit until foamy, about 5 minutes. Place flour, butter, remaining sugar, and salt in the work bowl fitted with the dough blade. Process to combine, about 20 seconds. Stir milk and egg into yeast mixture. With motor running, pour liquid mixture through the small feed tube as fast as the flour absorbs it. Process until dough cleans the sides of the work bowl, then process for 45 seconds to knead dough. Transfer to a plastic food storage bag and seal top. Let rise in a warm place until doubled in size, about 1½ hours.

## To make topping / assemble buns:

Insert metal blade in work bowl and pulse to coarsely chop pecans, about 5 to 6 times. Reserve. Combine sugar and cinnamon; reserve. Transfer dough to a lightly floured surface and punch dough down. Roll each half into a 9 x 9-inch square. Spread with softened butter, sprinkle with cinnamon/sugar mixture and top with raisins. Roll dough up tightly and pinch seam to seal. Using a sharp knife cut into 9 slices (about 1-inch thick).

Pour melted butter into a 9 x 9-inch baking pan. Sprinkle brown sugar and reserved pecans over butter. Place buns, cut side up, in pan. Cover with plastic wrap coated with vegetable oil cooking spray and let rise in a warm place for 40 minutes. Preheat oven to 375°F for 15 minutes before baking.

Bake in preheated oven until tops are well browned, about 30 minutes. Remove from oven and invert pan immediately onto serving plate, allowing sugar mixture to drip onto buns. Scrape any remaining sugar/nut mixture onto buns and serve warm.

*Nutritional information per sticky bun:*

*Calories 553 (39% from fat) • carb. 49g • pro. 5g • fat 16g • sat. fat 8g  
• chol. 54mg • sod. 143mg • calc. 23mg • fiber 2g*

## Sesame Dinner Rolls

Fresh from the oven, warm rolls make any dinner extra special.

Makes 16 rolls

- ½ cup plus 2 tablespoons evaporated nonfat milk**
- 1 package active dry yeast**
- 1½ tablespoons sugar**
- 1 large egg, beaten**
- 2¾ cups unbleached, all-purpose flour**
- 6 tablespoons unsalted butter, in 1-inch pieces**
- 1 teaspoon table salt**
- vegetable oil cooking spray**
- 1 large egg**
- 1 teaspoon water**
- 1 teaspoon sesame seeds**

In a small saucepan over medium heat, warm milk to 110-115°F. Remove from heat. Add yeast and sugar; stir to dissolve and let sit until foamy, about 5 minutes. Add beaten egg; stir gently to combine. Transfer to a 2-cup liquid measure and reserve.

Use dough blade to process flour, butter and salt until combined, about 15 to 20 seconds. With machine running, add yeast mixture through the small feed tube in a steady stream as fast as the flour absorbs it. After the dough forms a ball, process 45 to 50 seconds to knead. Place in a large plastic food storage bag and seal top. Let rise until doubled in size, about 1 to 1½ hours.

Lightly coat an 8-inch round baking pan with vegetable oil cooking spray. Place dough on a lightly floured surface and punch down. Divide dough into 16 equal pieces and shape each piece into a ball. Place balls in the pan so they are just touching each other. Cover with plastic wrap coated with vegetable oil cooking spray and let rise 1 hour. Preheat oven to 350°F for 15 minutes before baking.

Combine egg and water. Brush over rolls and sprinkle with sesame seeds. Bake in preheated oven until golden, about 35 to 40 minutes. Cool on wire rack.

*Nutritional information per roll:*

*Calories 130 (33% from fat) • carb. 18g • pro. 4g • fat 5g • sat. fat 3g  
• chol. 38mg • sod. 166mg • calc. 33mg • fiber 0g*

# Cheese Bread

This bread is excellent to serve with a hearty soup or for making sandwiches.

Makes 12 servings (one 1½-pound loaf)

- 1 package active dry yeast**
- 1 teaspoon granulated sugar**
- ¼ cup warm water (105-115°F.)**
- 3 ounces extra-sharp Cheddar**
- 3 cups unbleached, all-purpose flour**
- 2 tablespoons unsalted butter, in 1-inch pieces**
- 1 teaspoon table salt**
- ¾ cup nonfat milk**
- vegetable oil cooking spray**

In a 2-cup liquid measure dissolve yeast and sugar in warm water. Let stand until foamy, about 5 minutes.

Insert medium shredding disc and shred cheese using light pressure. Leave in work bowl. Remove shredding disc and insert dough blade. Add flour, butter and salt; process to combine, about 20 seconds. Add milk to yeast mixture. With machine running, pour milk mixture through small feed tube as fast as the flour absorbs it and process until dough cleans the sides of the work bowl. Then process for 45 seconds to knead dough. Place dough in a lightly floured plastic food storage bag and seal top. Let rise in a warm place until doubled in size, about 1 to 1½ hours.

Spray one 8 x 4-inch loaf pan with vegetable oil cooking spray. Place dough on a lightly floured surface and punch down. Roll dough into an 8 x 4-inch rectangle. Beginning with a short end, roll up the dough jelly-roll fashion. Pinch the seam and ends tightly to seal. Place in greased loaf pans and cover with plastic wrap coated with vegetable oil cooking spray. Let rise for 45 minutes. Preheat oven to 375°F for 15 minutes before baking.

Bake until top is well browned and loaf sounds hollow when tapped, about 35 to 40 minutes. Remove from pan and cool on wire rack.

*Nutritional information per serving:*

*Calories 155 (26% from fat) • carb. 23g • pro. 5g • fat 4g • sat. fat 3g  
• chol. 13mg • sod. 248mg • calc. 69mg • fiber 1g*

# Stollen

Our version of this traditional German Christmas bread is full of raisins and almonds, but low in fat.

Makes 12 servings (one loaf, about 1¼ pounds)

## **Dough:**

- 1 package active dry yeast**
- 3 tablespoons granulated sugar, divided**
- 3 tablespoons warm water (105-115°F.)**
- 1 strip lemon zest**

- 2 cups unbleached, all-purpose flour**
- 3 tablespoons unsalted butter, in 1-inch pieces**
- ½ teaspoon ground nutmeg**
- ½ teaspoon table salt**
- ⅓ cup raisins**
- ⅓ cup slivered almonds, divided (also used in filling)**
- ⅓ cup plus 1 tablespoon nonfat milk**
- 1 large egg**

**Filling:**

- 1⅓ tablespoons granulated sugar**
- ¼ teaspoon ground cinnamon**
- 1⅓ tablespoons unsalted butter, melted**
- vegetable oil cooking spray**

**Glaze:**

- ⅔ cup powdered sugar**
- 1 tablespoon water**

In a 2-cup liquid measure dissolve yeast and 1 teaspoon of sugar in warm water. Let sit until foamy, about 5 minutes.

Using metal blade, process zest and remaining sugar, about 45 seconds. Scrape work bowl and insert dough blade. Add flour, butter, nutmeg and salt to work bowl. Process for 20 seconds to combine. Add raisins and 3 tablespoons almonds; pulse to combine, about 3 to 4 times.

Add milk and egg to yeast mixture. With motor running, add liquid through small feed tube as fast as flour will absorb it, then process for 40 seconds to knead dough. Dough will be sticky and will not clean the sides of the work bowl or form a ball. Transfer dough to a large plastic food storage bag and seal the top. Let rise in a warm place until doubled in size, about 1 hour. Meanwhile, use metal blade to process remaining almonds, sugar and cinnamon until coarsely chopped, about 5 times. Reserve.

Place dough on a lightly floured surface and punch dough down. Roll dough into a 10 x 13-inch rectangle. Brush dough with half of melted butter and sprinkle with reserved almond/sugar mixture. Fold the two long sides of dough in towards the middle, overlapping slightly. Place on baking sheet coated with vegetable oil cooking spray and brush with remaining melted butter. Cover and let rise 45 minutes. Preheat oven to 375°F for 15 minutes before baking.

Bake until browned, about 20 to 25 minutes. Cool on wire rack. Meanwhile, use the metal blade to combine powdered sugar and water until smooth, about 15 to 20 seconds. Drizzle over stollen and serve warm.

*Nutritional information per serving:*

*Calories 142 (31% from fat) • carb. 29g • pro. 4g • fat 7g • sat. fat 3g  
• chol. 29mg • sod. 109mg • calc. 26mg • fiber 1g*

# Classic Cuisinart White Bread

Spoil your family with homemade bread.

Makes 16 servings (2 loaves, 1 pound each)

- 1 package active dry yeast**
- 2 teaspoons granulated sugar**
- 1/3 cup warm water (105-115°F)**
- 4 cups unbleached, all-purpose flour**
- 3 tablespoons unsalted butter, in 1-inch pieces**
- 1 1/2 teaspoons table salt**
- 1 cup cold water**
- vegetable oil cooking spray**

In a 2-cup liquid measure dissolve yeast and sugar in warm water. Let sit until foamy, about 5 minutes.

Insert dough blade. Process flour, butter and salt until combined, about 10 to 15 seconds. Add cold water to yeast mixture. With machine running, add liquid through small feed tube as fast as flour absorbs it. Once dough cleans the sides of the work bowl and forms a ball, process for 45 seconds to knead dough. Place dough in a lightly floured plastic food storage bag and seal the top. Allow to sit in a warm place until doubled in size, about 1 to 1 1/2 hours.

Spray two 8 x 4-inch loaf pans with vegetable oil cooking spray. Place dough on a lightly floured surface and punch down. Divide dough in half and roll each half into a 8 x 4-inch rectangle. Beginning with a short end, roll up the dough jelly-roll fashion. Pinch the seam and ends tightly to seal. Place in greased loaf pans and cover with plastic wrap coated with vegetable oil cooking spray. Let rise until dough is just above the tops of the pans, about 45 minutes to 1 hour. Preheat oven to 400°F for 15 minutes before baking.

Bake until tops are browned and loaf sounds hollow when tapped, about 30 to 35 minutes. Remove from pans and cool on wire rack.

*Nutritional information per serving:*

*Calories 136 (16% from fat) • carb. 25g • pro. 3g • fat 2g • sat. fat 1g  
• chol. 6mg • sod. 219mg • calc. 80mg • fiber 1g*

# Classic Cuisinart Wheat Bread

The nutty flavor of whole wheat makes this bread a favorite.

Makes 16 servings (2 loaves, 1 pound each)

- 1 package active dry yeast**
- 1 tablespoon granulated sugar**
- 1/3 cup warm water (105-115°F)**
- 2 cups unbleached, all-purpose flour**
- 2 cups whole-wheat flour**

- 3      tablespoons unsalted butter, in 1-inch pieces**
- 1½    teaspoons table salt**
- 1      cup cold water**
- vegetable oil cooking spray**

In a 2-cup liquid measure dissolve yeast and sugar in warm water. Let sit until foamy, about 5 minutes.

Insert dough blade. Process flours, butter and salt until combined, about 10 to 15 seconds. Add cold water to yeast mixture. With machine running, add liquid through small feed tube as fast as flour absorbs it. Once dough cleans the sides of the work bowl and forms a ball, process for 45 seconds to knead dough. Place dough in a lightly floured plastic food storage bag and seal the top. Allow to sit in a warm place until doubled in size, about 1 to 1½ hours.

Spray two 8 x 4-inch loaf pans with vegetable oil cooking spray. Place dough on a lightly floured surface and punch down. Divide dough in half and roll each half into a 8 x 4-inch rectangle. Beginning with a short end, roll up the dough jelly-roll fashion. Pinch the seam and ends tightly to seal. Place in greased loaf pans and cover with plastic wrap coated with vegetable oil cooking spray. Let rise until dough is just above the tops of the pans, about 45 minutes to 1 hour. Preheat oven to 400°F for 15 minutes before baking.

Bake until tops are browned and loaf sounds hollow when tapped, about 30 to 35 minutes. Remove from pans and cool on wire rack.

*Nutritional information per serving:*

*Calories 134 (17% from fat) • carb. 25g • pro. 4g • fat 3g • sat. fat 1g  
• chol. 6mg • sod. 220mg • calc. 45mg • fiber 2g*

## Pizza Dough

Once you see how simple Cuisinart pizzas are to make, you will never order one to be delivered again.

Makes ¾ pound dough (enough for two 9-inch crusts or one 14-inch crust)

- 1      package active dry yeast**
- 1      teaspoon granulated sugar**
- ⅔     cup warm water (105-115°F)**
- 1⅓    cups unbleached, all-purpose flour**
- ¾     teaspoon table salt**
- ¾     teaspoon extra virgin olive oil**

In a 2-cup liquid measure, dissolve yeast and sugar in warm water. Let stand until foamy, about 3 to 5 minutes. Insert metal blade in work bowl and add flour and salt. Add cold water to yeast mixture.

With machine running, pour liquid through small feed tube as fast as flour absorbs it. Process until dough cleans sides of work bowl and forms a ball. Then process for 30 seconds to knead dough. Dough may be slightly sticky. Coat dough evenly with olive oil; transfer to a plastic food storage bag and seal the top. Let rise in a warm place for about 45 minutes.

Place dough on a lightly floured surface and punch down. Roll into desired crust sizes and place on baking pans lightly sprayed with vegetable oil cooking spray. Follow pizza recipe.

*Nutritional information per serving (12 servings):*  
Calories 69 (6% from fat) • carb. 14g • pro. 2g • fat 0g • sat. fat 0g  
• chol. 0mg • sod. 202mg • calc. 44mg • fiber 1g

## Cranberry–Orange Bread

Apples make this bread very moist – for a breakfast treat, slice and toast.

Makes 1 loaf (14 servings)

**nonstick oil cooking spray**

**1¼ cups unbleached, all-purpose flour**

**1½ teaspoons baking powder**

**¼ teaspoon table salt**

**¾ cup pecan halves, shelled**

**3 strips orange zest**

**⅔ cup granulated sugar**

**1 small apple (about 5 ounces total), peeled, cored, cut into 1-inch pieces**

**1 large egg**

**½ teaspoon pure vanilla extract**

**¼ cup unsalted butter, melted**

**3 tablespoons buttermilk**

**⅓ cup plus 1 tablespoon dried cranberries**

Preheat oven to 350°F. Lightly spray an 8 x 4-inch loaf pan with vegetable oil cooking spray. In a small bowl combine flour, baking powder and salt. Reserve. Insert metal blade and pulse to chop pecans coarsely, about 6 times. Reserve.

Process orange zest and sugar until zest is finely chopped, about 45 seconds. Add apple, egg and vanilla; process until combined, about 15 to 20 seconds. With machine running add butter and buttermilk through the small feed tube. Process until combined, about 10 to 15 seconds. Add cranberries, pecans and dry ingredients. Pulse until flour is just mixed in, about 5 to 6 times. Do not overprocess.

Transfer batter to prepared pan. Bake until golden brown and a toothpick inserted in the center comes out clean, about 55 to 60 minutes. Cool in pan on a wire rack. Remove from pan and cool completely. For best results, wrap in plastic wrap and allow to rest for 24 hours before slicing.

*Nutritional information per serving:*  
Calories 169 (42% from fat) • carb. 23g • pro. 2g • fat 8g • sat. fat 3g  
• chol. 24mg • sod. 81mg • calc. 13mg • fiber 1g

# Lowfat Banana Nut Bread

Wrap and freeze individual slices for a healthy lunchbox snack.

Makes 1 loaf (12 servings)

- nonstick cooking spray**
- 1 cup unbleached, all-purpose flour**
- 3 tablespoons walnut halves, shelled**
- ½ teaspoon baking powder**
- ½ teaspoon baking soda**
- ¼ teaspoon table salt**
- 1 ripe banana (about 5½ ounces), peeled, cut into 1-inch pieces**
- 1 large egg**
- 1 large egg white**
- ½ cup granulated sugar**
- ¼ cup plain nonfat yogurt**
- 2 tablespoons unsalted butter, in 1-inch pieces**
- 1 teaspoon pure vanilla extract**

Preheat oven to 350°F. Lightly coat an 8 x 4-inch loaf pan with nonstick cooking spray. Insert metal blade. Pulse to combine flour, nuts, baking powder, baking soda and salt, about 5 times. Reserve.

Process banana until puréed, about 30 seconds. Scrape work bowl and process an additional 10 seconds. Add egg, egg white, sugar, yogurt, butter and vanilla extract. Process until well combined, about 10 to 15 seconds. Add dry ingredients. Pulse until flour is just mixed in, about 5 to 6 times.

Pour into prepared pan. Bake until golden brown and a toothpick inserted in the center comes out clean, about 50 minutes. Cool in pan on a wire rack for 20 minutes. Remove from pan and cool completely on wire rack.

*Nutritional information per serving:*

*Calories 109 (22% from fat) • carb. 19g • pro. 2g • fat 3g • sat. fat 1g  
• chol. 23mg • sod. 135mg • calc. 39mg • fiber 1g*

**Variation:** For muffins, lightly spray 12 standard (½-cup) muffin cups with nonstick cooking spray. Divide the batter evenly among the 12 cups. Bake at 350°F for 16 to 20 minutes. For variety, add ¼ cup chocolate chips when pulsing in the flour mixture.

## Carrot-Raisin Muffins

Moist and tasty breakfast treats, these muffins freeze well.

Makes 12 muffins

- 1½ cups unbleached, all-purpose flour**
- 1 cup bran flakes cereal**
- 1 tablespoon baking powder**
- ½ teaspoon ground cinnamon**

- ¼ teaspoon table salt**
- 1 medium carrot (about 3 ounces), peeled, cut to fit feed tube vertically**
- ⅓ cup walnut halves, shells removed**
- 3 strips orange zest**
- ⅔ cup firmly packed dark brown sugar**
- ¾ cup fat-free milk**
- 1 large egg**
- ¼ cup vegetable oil**
- ½ cup raisins**

Line 12 standard muffin cups with paper liners. Preheat oven to 375°F. In a small bowl combine flour, bran flakes, baking powder, cinnamon and salt; reserve.

Insert the medium shredding disc. Stand carrots upright in the feed tube and shred using medium pressure; reserve. Insert metal blade and pulse to coarsely chop walnuts, about 7 to 8 times. Reserve. Add orange zest and brown sugar; process until combined, about 20 to 30 seconds. Scrape bowl. Add milk, egg and oil. Process until combined, about 5 to 10 seconds. Add raisins, walnuts, carrots and dry ingredients. Pulse until flour is just mixed in, about 5 times.

Fill muffin cups ¾ full with batter. Bake until light golden brown on top and a toothpick inserted in the center comes out clean, about 20 to 25 minutes. Remove from pan and cool on wire rack.

*Nutritional information per muffin:*

*Calories 205 (32% from fat) • carb. 32g • pro. 4g • fat 7g • sat. fat 1g  
• chol. 18mg • sod. 213mg • calc. 92mg • fiber 2g*

## Mocha-Pecan Coffee Cake

This do-ahead coffee cake will be a favorite for brunch.

Makes 16 servings

- nonstick cooking spray**
- ½ cup pecan halves**
- ⅓ cup semisweet chocolate chips**
- 3 tablespoons firmly packed light brown sugar**
- ¾ teaspoon instant coffee granules**
- 1½ cups unbleached, all-purpose flour**
- 1½ teaspoons baking powder**
- ¼ teaspoon table salt**
- 1⅓ cups granulated sugar**
- ¾ cup unsalted butter, in 1-inch pieces**
- 1 large egg**
- ¾ teaspoon pure vanilla extract**
- ¾ cup plus 2 tablespoons lowfat sour cream**

Preheat oven to 350°F. Lightly coat an 8-inch square baking pan with vegetable oil cooking spray. Insert metal blade in work bowl. Process pecans, chocolate chips, brown sugar and coffee granules until coarsely chopped, about 10 seconds. Reserve and wipe work bowl clean.

Combine flour, baking powder and salt in a small bowl; reserve. Process sugar and butter until creamy, about 20 seconds. Scrape work bowl and process an additional 15 to 20 seconds. Add egg and vanilla; process until smooth, about 30 seconds. Add sour cream; process until well combined, about 10 seconds. Scrape work bowl. Add reserved dry ingredients. Pulse until just incorporated, about 10 times.

Layer half of the batter, two-thirds of the topping, the remaining batter and remaining topping in prepared pan. Gently swirl with a knife to combine batter and topping. Bake until golden brown and a toothpick inserted in the center comes out clean, about 55 to 65 minutes. Cool in pan on a wire rack for 20 to 30 minutes. Remove from pan and cool completely. For best results, wrap in plastic wrap and allow to rest for 24 hours before slicing.

*Nutritional information per serving:*

*Calories 256 (45% from fat) • carb. 33g • pro. 2g • fat 13g • sat. fat 7g  
• chol. 38mg • sod. 77mg • calc. 60mg • fiber 1g*

## Jalapeño Cornbread

Serve warm from the oven with Cilantro Lime Butter (recipe follows)

Makes 9 servings

**nonstick cooking spray**

**1 cup yellow cornmeal**

**¾ cup unbleached, all-purpose flour**

**2½ teaspoons baking powder**

**½ teaspoon granulated sugar**

**¼ teaspoon table salt**

**1 small jalapeño pepper, seeded, cut into ½-inch pieces**

**1 cup nonfat milk**

**1 large egg**

**1 tablespoon unsalted butter, melted**

Preheat oven to 400°F. Lightly coat an 8 x 8-inch baking pan with nonstick cooking spray. In a small bowl combine cornmeal, flour, baking powder, sugar and salt. Reserve.

Insert metal blade. Process jalapeño until finely chopped, about 5 seconds. Scrape bowl. Add milk, egg and butter; process to combine, about 5 to 10 seconds. Add dry ingredients. Pulse until flour and cornmeal are just combined, about 6 to 7 times. Pour into prepared pan and bake until golden and top springs back when touched, about 20 minutes. Cut into squares and serve warm with Cilantro-Lime Butter (recipe follows).

*Nutritional information per serving:*

*Calories 112 (19% from fat) • carb. 19g • pro. 4g • fat 2g • sat. fat 1g  
• chol. 27mg • sod. 220mg • calc. 85mg • fiber 2g*

# Cilantro-Lime Butter

This compound butter is delicious on fresh corn on the cob.

Makes ½ cup

- ¼ **cup fresh cilantro, washed and dried**
- 1 **strip lime zest**
- 1 **stick (½ cup) unsalted butter, softened**

Insert metal blade. Process cilantro and zest until finely chopped, about 20 seconds. Scrape bowl and process an additional 20 seconds. Add butter; process until smooth and well blended, about 15 seconds. Scrape bowl and process an additional 10 to 15 seconds.

*Nutritional information per teaspoon:*

*Calories 67 (100% from fat) • carb. 0g • pro. 0g • fat 7g • sat. fat 5g  
• chol. 20mg • sod. 0mg • calc. 0mg • fiber 0g*

# Almond-Pear Bread

Almonds and pears combine to make this rich, moist tea bread.

Makes 12 servings

## **Paste:**

- ½ **cup blanched almonds**
- ⅓ **cup granulated sugar**
- 1 **tablespoon plus 1 teaspoon water**
- ⅛ **teaspoon almond extract**

## **Bread:**

- nonstick cooking spray**
- ⅓ **cup sliced almonds**
- ¾ **cup plus 2 tablespoons unbleached, all-purpose flour**
- 1½ **teaspoons baking powder**
- ¼ **teaspoon table salt**
- ⅛ **teaspoon baking soda**
- ½ **pound ripe pears, peeled, cored, cut into 1-inch pieces**
- 1 **large egg**
- ½ **cup almond paste**
- ¼ **cup unsalted butter, softened, cut into 1-inch pieces**

## **To make paste:**

Use metal blade to process blanched almonds and sugar until finely ground, about 60 seconds. With machine running, add water and extract; process until combined, about 45 to 60 seconds longer. Paste can be made ahead and stored in the refrigerator in an airtight container for up to two weeks.

## **To make bread:**

Preheat oven to 350°F. Lightly coat one 8 x 4-inch loaf pan with the nonstick cooking spray. Toast sliced almonds on a baking sheet until lightly browned, about 8 to 10 minutes. In a small bowl combine flour, baking powder, salt and baking soda; reserve.

Insert metal blade and process pears, egg, almond paste and butter until combined, about 30 seconds. Scrape bowl and process an additional 30 to 45 seconds. Add toasted almonds and reserved dry ingredients. Pulse to combine, about 6 to 7 times. Pour into prepared pan and bake until golden brown on top and a toothpick inserted in the center comes out clean, about 1 hour. Cool on wire rack for 30 to 40 minutes. Remove from pan and cool completely on wire rack. For best results wrap bread in plastic wrap and allow to rest for 24 hours before slicing.

*Nutritional information per serving:*

*Calories 165 (40% from fat) • carb. 22g • pro. 4g • fat 8g • sat. fat 1g  
• chol. 18mg • sod. 62mg • calc. 62mg • fiber 2g*

## Popovers with Variations

As this batter bakes, it “pops over” the sides of the baking cups.

Makes 6 popovers

- ¾ cup unbleached, all-purpose flour**
- ¾ cup lowfat milk**
- 2 large eggs**
- 1 tablespoon unsalted butter, melted**
- ½ teaspoon sea or table salt**
- ¼ teaspoon freshly ground black pepper**
- nonstick cooking spray**

Insert the metal blade. Process the flour, milk, eggs, butter, salt and pepper until smooth, 25 to 30 seconds. Remove to a large measuring cup and allow to rest at room temperature for 30 to 45 minutes.

Preheat the oven to 450° F. Spray 6 muffin cups (½-cup size) with nonstick cooking spray. Set aside.

Divide the batter among the prepared muffin tins, filling each one about three-quarters full. Bake in the preheated hot oven (450° F) for 20 minutes. Do not peek or disturb, or the popovers might fall. Lower the heat to 375° F, and bake for 20 minutes. Remove from the pans and serve immediately.

*Nutritional information per popover:*

*Calories 107 (36% from fat) • carb. 13g • pro. 5g • fat 4g • sat. fat 2g  
• chol. 79mg • sod. 236mg • calc. 53mg • fiber 0g*

### Variations:

**Pesto:** Add 3 tablespoons Pesto, page 32, to the batter with the other ingredients. The baking time and temperature will remain the same.

**Roasted Shallot and Rosemary:** Before making the batter, insert the metal blade and chop 2 tablespoons fresh rosemary leaves using a short, quick pulse, 20 times. Add 2½ ounces of shallots that have been roasted, and process until smooth, 25 to 30 seconds. Continue with the recipe; the baking time and temperature will remain the same.



## French Cut Green Beans with Shallots

The time-consuming French cut takes just seconds with a Cuisinart food processor.

Makes 6 servings

- 1½ pounds fresh green beans, trimmed, cut to fit feed tube horizontally**
- 3 large shallots, cut into 1-inch pieces**
- 1½ tablespoons olive oil**
- 6 tablespoons water**
- 2¼ teaspoons balsamic vinegar**
- ¼ teaspoon white pepper**
- ¼ teaspoon kosher salt**

Insert the slicing disc. Place beans horizontally in large feed tube and process using light pressure. Remove and reserve.

Insert metal blade. Process shallot until finely chopped, about 5 seconds.

Warm oil in a 3½-quart sauté pan over medium heat. Add chopped shallots and sauté until soft but not browned, about 2 minutes. Add green beans and sauté for 3 to 4 minutes. Add water and reduce heat to low. Cover pan and cook until crisp tender, about 8 to 10 minutes. Remove from heat and add vinegar. Season with pepper and salt. Serve warm.

*Nutritional information per serving:*

*Calories 80 (45% from fat) • carb. 9g • pro. 2g • fat 4g • sat. fat 0g  
• chol. 0mg • sod. 81mg • calc. 44mg • fiber 4g*

## Glazed Carrots

A traditional favorite, updated with the zesty flavor of balsamic vinegar.

Makes 6 servings

- 1½ pounds carrots, peeled, cut to fit feed tube vertically**
- ⅓ cup firmly packed light brown sugar**
- 1 ounce fresh gingerroot, peeled, cut into ½-inch pieces**
- 4 strips orange zest, bitter white pith removed**
- 1½ tablespoons unsalted butter**
- 1 cup orange juice**
- 1½ tablespoons balsamic vinegar**

Insert the slicing disc. Place carrots in feed tube vertically and slice, using medium pressure. Remove and reserve.

Insert metal blade. Process brown sugar, gingerroot and zest until finely chopped, about 15 seconds.

Melt butter in a 3¾-quart saucepan over medium heat. Add zest mixture, juice and vinegar. Bring to a boil and add carrots. Reduce heat to medium-low. Cover and simmer until carrots are tender and glazed, about 13 to 16 minutes.

*Nutritional information per serving:*

*Calories 144 (17% from fat) • carb. 2g • pro. 1g • fat 3g • sat. fat 2g  
• chol. 8mg • sod. 46mg • calc. 49mg • fiber 3g*

## Potato and Leek Gratin

Leeks grow in very sandy soil, so wash thoroughly to remove all grit before using.

Makes 12 servings

**nonstick cooking spray**

- 1 pound leeks, cleaned well, tough outer layer removed, trimmed to about an inch of green above the white bulb, cut into 1-inch lengths**
- 2 tablespoons unsalted butter**
- 3 ounces good quality white bread**
- 1½ ounces Reggiano Parmigiano, cut into ½-inch pieces**
- 6 ounces Gruyère (not processed)**
- 2¼ pounds russet or gold potatoes, peeled, cut flat at ends**
- 1 can (12 ounces) evaporated skimmed milk, not reconstituted**
- 1¼ cups lowfat milk**
- ½ cup heavy cream**
- ¾ teaspoon ground nutmeg**
- ¾ teaspoon freshly ground black pepper**
- 1 teaspoon kosher salt**

Preheat the oven to 375°F. Spray a shallow 2½-quart ovenproof casserole dish with cooking spray. Cut a sheet of aluminum foil large enough to cover the casserole, spray one side of the foil with cooking spray and set aside.

Insert the metal blade. Place leeks in work bowl and pulse to chop, about 10 pulses. In a medium skillet, melt 1 tablespoon of the butter. Add the leeks, and cook over low heat for 20 to 25 minutes until they are light caramel in color. Remove from the heat and allow to cool.

Wipe out work bowl to dry. Add the bread to the work bowl and pulse to achieve coarse crumbs, about 20 to 25 pulses. With the machine running, drop the remaining butter down the small feed tube and process until the crumbs are medium and the butter is evenly distributed, about 30 seconds. Remove and reserve. With the machine running, drop the Parmesan down the small feed tube and process to chop finely, 10 to 15 seconds; leave in work bowl.

Insert the shredding disc; shred the Gruyère using medium pressure. Add one half cup of the cheeses to the breadcrumb mixture, reserve. Remove and reserve the remaining cheeses.

Insert the slicing disc. Use medium pressure to slice the potatoes. Neatly layer ⅓ of the potato slices in the bottom of the casserole. Top with half of the grated cheeses and half

of the cooled caramelized leeks. Repeat, ending with a layer of the potatoes.

In a large saucepan, combine the milk, cream, nutmeg, pepper and salt. Stirring, bring this mixture to a boil. Carefully pour over the layered potatoes, leeks and cheeses. Top evenly with the buttered crumb and cheese mixture. Loosely cover with the foil and place in the preheated oven for 1½ hours. Test the potatoes for doneness. Depending on the type of potato, it may take up to 2 hours until tender. When the potatoes are tender, remove the foil and bake for 15 to 20 minutes longer, until the topping is light golden and crispy. Allow the gratin to rest for 15 to 20 minutes before serving.

*Nutritional information per serving:*

*Calories 248 (44% from fat) • carb. 24g • pro. 11g • fat 12g • sat. fat 7g  
• chol. 39mg • sod. 396mg • calc. 337mg • fiber 3g*

## Roasted Garlic and Parmesan Twice Baked Potatoes

Do these potatoes ahead to serve with grilled filets or London Broil.

Makes 4 servings

- 6 garlic cloves**
- extra virgin olive oil**
- 4 large baking potatoes (about 8 ounces each), washed, pierced with a knife**
- 2 ounces Parmesan, cut into 1-inch pieces**
- 2 scallions, trimmed, cut into 1-inch pieces**
- ½ cup evaporated skim milk**
- 2 tablespoons unsalted butter, cut into 1-inch pieces**
- ¼ teaspoon white pepper**
- ¼ teaspoon kosher salt**

Preheat oven to 400°F. Place garlic cloves in a small ovenproof ramekin and drizzle with olive oil. Cover with aluminum foil. Lightly brush potatoes with olive oil. Place garlic and potatoes in preheated oven; roast garlic for 30 to 40 minutes and bake potatoes until fork-tender, about 1 hour. When cool enough to handle, cut off part of top of potato and scoop out flesh, leaving a ¼-inch thick shell. Reserve flesh and skins.

Insert metal blade. With machine running drop cheese through small feed tube and process until finely grated, about 30 seconds; reserve. Place scallions in work bowl and process until finely chopped, about 5 to 10 seconds. Scrape work bowl. Add garlic, milk, butter, reserved cheese, pepper and salt. Process until combined, about 12 seconds. Add potato flesh; pulse in very short quick pulses until just combined, about 10 to 12 times. Scrape bowl and pulse in very short quick pulses about 10 more times. Generously fill skins with potato-garlic mixture. Potatoes may be made ahead to this point and refrigerated until ready to bake.

Preheat oven to 350°F. Place potatoes in a 9-inch square baking pan and bake, uncovered, until tops are golden brown and potatoes are hot, about 20 to 25 minutes.

*Nutritional information per serving:*

*Calories 322 (28% from fat) • carb. 46g • pro. 12g • fat 10g • sat. fat 6g  
• chol. 23mg • sod. 425mg • calc. 309mg • fiber 5g*



# Entrées

## Chili Lime Chicken with Grilled Pineapple and Zucchini

A wonderful summertime supper for the grill.

Makes 4 entrée servings

- 2 medium zucchini, about 6 ounces each, cleaned and trimmed to 4-inch lengths**
- ¼ fresh pineapple peeled and cored, cut to fit the feed tube**  
**zest of 2 limes, bitter white pith removed**
- 1 garlic clove**
- ¼ cup fresh cilantro, loosely packed**
- 2 teaspoons kosher salt**
- 1 jalapeño pepper, about 3 inches in length, stemmed, halved and seeded**
- ½ cup fresh lime juice**
- 2 tablespoons orange marmalade**
- 2 teaspoons chili powder**
- ¼ cup extra virgin olive oil**
- 4 boneless, skinless chicken breast halves, pounded to an even thickness, about ½ inch**

Insert the slicing disc. Place the zucchini in the feed tube horizontally; use medium pressure to slice. Remove and reserve. Place the pineapple wedges in the feed tube; use medium pressure to slice. Remove and reserve.

Insert the metal blade. Use the pulse to chop the lime zest, about 10 times. With the machine running, drop the garlic down the feed tube to chop, 5 seconds. Add the cilantro, salt and jalapeño, pulsing to chop, 5 times. Add the lime juice, marmalade, and chili powder, process to combine, and with the machine running, add the olive oil in a steady stream, processing until emulsified, about 30 seconds.

Place the chicken in a shallow dish or large sealable plastic bag. Add half the marinade, turning the chicken thoroughly to coat. Allow to marinate for at least 30 minutes, but no longer than an hour. Add half the remaining marinade to the zucchini, and the remaining marinade to the pineapple, toss each gently to coat.

Preheat an indoor or outdoor grill. When hot, grill the chicken, about 5 to 6 minutes per side. The chicken is done when the juices no longer run pink when tested; take care not to overcook. Remove to a warm platter, cover loosely and reserve.

Drain the zucchini and pineapple. Grill 2 to 3 minutes on each side until tender.

To serve, arrange a fan of zucchini and pineapple slices on each plate and top with a chicken breast. The remaining zucchini and pineapple may be combined and passed as a side dish.

*Nutritional information per serving:*  
Calories 448 (35% from fat) • carb. 17g • pro. 56g • fat 17g • sat. fat 3g  
• chol. 137mg • sod. 1249mg • calc. 59mg • fiber 2g

## Greek Burgers with Feta and Olive Tapenade

Makes 4 burgers

- 1 small garlic clove**
- 1 tablespoon fresh parsley, well packed**
- 1½ tablespoons capers, drained, rinsed and drained again**
- 2 ounces pitted imported green olives**
- ½ teaspoon fresh lemon juice**
- 1 tablespoon extra virgin olive oil**
- 1¼ pounds well-trimmed sirloin (include 1½ ounces of the hard fat), be sure all the gristle has been removed, cut into 1-inch cubes, frozen for 20 minutes**
- 2 teaspoons dried basil**
- 1 teaspoon dried oregano**
- ½ teaspoon freshly ground black pepper**
- 2 ounces feta, well drained and crumbled**
- 4 good quality rolls**
- mesclun or other lettuce**
- 1 roasted red bell pepper, drained and cut into ½-inch strips**

Insert the metal blade. With the machine running, drop the garlic down the feed tube; process 5 seconds to chop finely. Add the parsley, pulse to chop. Add the capers and olives, pulse to chop, 10 times. With the machine running, add the lemon juice and olive oil through the feed tube, process until the mixture has formed a rough paste, about 20 seconds. Remove and reserve. The tapenade may be made up to 2 days ahead.

Process the hard fat for 15 seconds to chop finely. Pulse the beef to rough chop, 15 to 20 times. Add the seasonings, pulsing to chop the beef further and incorporate the seasonings, another 15 times; do not overprocess. Add the feta, pulse to incorporate.

Divide the meat into 16 equal portions, and flatten to 4 inches in diameter. Top 8 of the rounds with a scant tablespoon of the olive tapenade, keeping a half-inch border all around. Place another burger patty on top of each one and press to seal. The burgers may be made ahead to this point, covered and refrigerated.

Preheat a grill pan or outdoor grill to very hot (a drop of water will dance when splattered on the grill pan). Cook the burgers over high heat, turning once, 4 to 6 minutes per side, depending on the desired degree of doneness.

Serve on rolls lined with lettuce, top with roasted red pepper strips and traditional tzatziki sauce.

*Nutritional information per burger:*  
Calories 504 (37% from fat) • carb. 22g • pro. 56g • fat 21g • sat. fat 7g  
• chol. 106mg • sod. 699mg • calc. 152mg • fiber 2g

# Roasted Pork Loin with Apple, Onion and Dried Plum Stuffing

The roast can be prepared ahead of time, making this a great dish for entertaining.

Makes 8 servings

- 24 dried pitted plums or prunes**
- ¾ cup Applejack or brandy, divided**
- 2 ounces shallots**
- 2 garlic cloves**
- 1½ tablespoons herbes de Provence**
- 2 teaspoons kosher salt**
- 1 teaspoon freshly ground black pepper**
- 1 three-pound boneless pork loin roast, whole, not cut and tied, well trimmed, with just a thin layer (1/8 inch or less) of fat remaining on top**
- 1½ pounds onions, halved vertically**
- 1½ pounds apples, peeled, cored and halved**
- 1 teaspoon extra virgin olive oil**
- 1 cup nonfat chicken stock**
- ½ cup heavy cream**
- nonstick cooking spray**

Place the dried plums in a heatproof bowl. Heat half of the applejack or brandy and pour it over the dried plums; cover and allow the plums to macerate for at least 30 minutes. Insert the metal blade. With the machine running, drop the shallots and garlic through the small feed tube to chop, 10 seconds. Scrape the work bowl. Add the herbes de Provence, salt and pepper; process until a paste is formed, 30 to 40 seconds. Remove and reserve. Do not wash work bowl.

Place the roast on a cutting surface, fat side down. With sharp boning knife, cut down the center of the roast to within ½ inch of the other side – the roast will open like a book. Carefully cut through the center of one side of the roast to within ½ inch of the edge; open this side flat like a book. Repeat on the other side. Cover the open roast with a sheet of plastic wrap and pound with a flat meat pounder to even out. Rub both sides of the roast with the shallot mixture. Cover and refrigerate.

Insert the slicing disc. Slice the onions; remove and reserve. Slice the apples; remove and reserve. Heat the olive oil in a 5½-quart sauté pan over medium high heat. When hot, add the onions and cook until wilted, about 3 minutes. Add the sliced apples. Cook, stirring now and then, until the apples and onions are just tender and beginning to turn light golden brown, about 12 to 15 minutes. Remove; spread out on a baking sheet and let cool completely before continuing.

When the onion/apple mixture is cool, spread a ½-inch layer on the cut side of the roast to within 1 inch of the edges. Drain the plums and arrange in a double row down the center of the roast. Roll the roast and tie with butcher's twine, with the twine looped at 1-inch intervals. Pass the string around the loin ends and secure it through the loops on the other side. The roast may be done ahead to this point and refrigerated. Refrigerate the remaining onion/apple mixture.

Preheat the oven to 400°F. Spray a roasting pan with nonstick vegetable oil spray. Spread the remaining onion/apple mixture in the bottom of the pan. Place the pork roast on top. Roast at 400°F for 15 minutes, then lower heat to 375°F. Continue to roast for another 45 to 60 minutes, until the internal temperature of the roast measures 150°F when tested with an instant-read thermometer. Remove from the oven, transfer to a warmed platter, and cover loosely with foil. Let the roast rest for 20 minutes.

Strain the pan juices into a fat separator. Discard fat and pour the pan juices into a 2-quart Windsor pan. Add the remaining applejack and the chicken stock to the saucepan and bring to a boil; reduce by half. Add the cream; simmer for 10 minutes. Strain the sauce and keep warm.

To serve, slice the pork roast into ½-inch slices after it has rested. Serve with the sauce. This roast is also very good when roasted a day ahead. Allow to cool, then wrap and refrigerate. Slice just before serving.

*Nutritional information per serving:*

*Calories 549 (37% from fat) • carb. 34g • pro. 46g • fat 21g • sat. fat 8g  
• chol. 139mg • sod. 554mg • calc. 69mg • fiber 5g*

## Salmon and Pesto Potatoes

Just add a simple green salad for a quick and easy dinner.

Makes 4 servings

- 1     tablespoon extra virgin olive oil**
- 4     Yukon Gold or other new potatoes, 4 ounces each, well scrubbed, opposite ends trimmed flat with a knife**
- 4     teaspoons Pesto, p. 32**
- 1¼   pounds boneless, skinless salmon fillet, cut into 5-ounce portions**
- ½     teaspoon kosher salt**
- ¼     teaspoon freshly ground pepper**
- 4     fresh basil leaves**

Preheat the oven to 400°F. Cut 4 pieces of aluminum foil, each 16 inches long.

Brush a 4 x 6-inch area in the center of each rectangle with olive oil. Set aside.

Insert the slicing disc. Slice the potatoes, one at a time; remove each potato, restack and reserve separately. Blanch potatoes in boiling water for 3 to 4 minutes. Drain and let cool.

Season each salmon fillet with salt and pepper. Fan out the slices of one potato on the oiled portion of a sheet of foil. Spread one teaspoon of the Pesto on the fanned slices. Top with a salmon fillet. Bring the two cut sides of the foil together over the center of the salmon, fold over 1 inch, then fold over 2 more times. Fold the ends in twice, in ½-inch folds, to complete the seal. Repeat until all the salmon and potatoes have been prepared and wrapped. Bake in the preheated oven for 18 minutes. While the salmon is in the oven, stack the basil leaves and roll. Slice in ⅛-inch intervals to create a chiffonade. The packets will be puffed; prick with the tip of a sharp knife to vent the steam, then carefully open. Serve immediately on warmed plates sprinkled with the basil chiffonade.

*Nutritional information per serving:*

*Calories 367 (31% from fat) • carb. 27g • pro. 34g • fat 12g  
sat. fat 2g • chol. 72mg • sod. 266mg • fiber 2g*



## Pesto, Cheese and Fresh Tomato Pizza

Homemade pesto and fresh, ripe tomatoes from the garden make this a great summertime pizza.

Makes 1 pizza (14-inch) or 2 pizzas (9-inch) to serve 4

**pizza dough, page 47**

- ½ pound firm but ripe plum tomatoes**
- ½ ounce Reggiano Parmesan, cut into ½-inch cubes**
- 2 ounces fresh mozzarella, well chilled**
- 1½ ounces Italian Fontina cheese**
- 3 tablespoons Pesto, page 32**
- 1 teaspoon extra virgin olive oil**
- cornmeal for dusting the peel or pan**

Prepare the pizza dough and let it rise. Position the top rack of the oven about 8 inches from the top. If using a baking stone, place it on the rack. Preheat the oven to 500°F while preparing the pizza.

Bring 6 cups of water to a boil in medium saucepan. Cut a shallow “x” in the bottom of each tomato. Blanch the tomatoes in the boiling water for 30 seconds, then immediately plunge them into a bowl of iced water. When cool enough to handle, slip the skins off. Slice the stem end off each tomato; set aside.

Insert the metal blade. With the machine running, drop the Parmesan cheese cubes down the small feed tube; process 15 seconds and leave in bowl. Insert the shredding disc and shred the mozzarella and Fontina. Remove the cheese to a bowl; toss to combine, and reserve. Insert the slicing disc. Place the tomatoes in the small feed tube one at a time, and slice, using light pressure. Place the sliced tomatoes on a triple thick layer of paper towels to drain.

When the dough has risen, punch down and divide into 2 or 4 equal balls. Let rest 10 minutes. Roll the dough out to size. Place on a baker’s peel that has been sprinkled with cornmeal. Brush the edges with the olive oil. Using an offset spatula, spread the pizza to ¾ inch of the edges with the pesto sauce, using 3 tablespoons on each 14-inch pizza or 1½ tablespoons on each 9-inch pizza. Divide the shredded cheeses evenly and sprinkle on the pizzas. Top with the drained sliced tomatoes.

Carefully slide the pizza onto the stone (position the peel over the back edge of the stone, and use a rocking motion to shake and slide the pizza off the peel onto the stone), or place the pan in the hot oven. Bake the pizza for 5 minutes, then rotate it front to back for even baking. Bake for another 3 to 6 minutes, until the pizza is bubbly, and the edges of the dough are golden brown, puffed and crispy. Remove from the oven and let rest on a rack for 2 to 3 minutes before slicing.

*Nutritional information per serving (four servings):*

*Calories 363 (35% from fat) • carb. 45g • pro. 14g • fat 14g • sat. fat 6g  
• chol. 27mg • sod. 721mg • calc. 336mg • fiber 3g*

# Desserts



## Hazelnut Butter Cookies

Melt-in-your-mouth delicious – keep this cookie dough on hand frozen and ready to bake when unexpected guests drop in.

Makes about 70 cookies

- 1¼ cups unbleached, all-purpose flour**
- ¾ cup (4 ounces) lightly toasted hazelnuts**
- ¼ teaspoon table salt**
- 12 ounces unsalted butter, at room temperature**
- ¾ cup powdered sugar**
- 1 tablespoon pure vanilla extract**

Insert the metal blade. Process the flour, hazelnuts, and salt, using the pulse, 15 to 20 times, to chop the hazelnuts and combine with the flour. Remove and reserve.

Process the butter, powdered sugar and vanilla until smooth and creamy. Add the reserved flour mixture and process until the dry ingredients are just incorporated. Turn out onto a lightly floured surface. Shape into 2 equal balls, wrap in plastic wrap. Refrigerate for about 30 minutes, until stiff enough to shape into logs. Shape into logs 10 inches long and 1¼ inches in diameter. Wrap well in plastic wrap, and refrigerate until firm, or double-wrap and freeze.

When ready to bake, preheat the oven to 350°F. Slice ¼-inch thick and place 2 inches apart on ungreased baking sheets. Bake in the preheated oven for 10 to 14 minutes, until the edges just begin to turn brown. Let cool on the baking sheets for 1 minute, then transfer to a rack to cool completely.

*Nutritional information per cookie:*

*Calories 56 (77% from fat) • carb. 3g • pro. 0g • fat 5g • sat. fat 0g  
• chol. 10mg • sod. 8mg • calc. 4mg • fiber 0g*

## Lemon Ginger Biscotti

Delicious with coffee or tea.

Makes about 50 biscotti

- 1½ ounces white chocolate, such as Lindt or Callebaut, broken up, chilled**
- 1 ounce crystallized ginger**
- 1¼ cups unbleached, all-purpose flour**
- 1 teaspoon baking powder**
- ⅛ teaspoon table salt**
- zest of 1½ lemons, removed with a vegetable peeler,  
bitter white pith removed**
- ¼ cup plus 2 tablespoons granulated sugar**

- ¼ cup unsalted butter, at room temperature**
- 1 large egg**
- ½ tablespoon brandy**
- ½ tablespoon pure vanilla extract**

Preheat the oven to 325°F.

Insert the metal blade. Use the pulse to chop the white chocolate, about 5 to 10 times; there should be no pieces larger than ½ inch. Remove and reserve. Use the pulse to chop the crystallized ginger, 10 to 15 times; there should be no pieces larger than ½ inch. Remove and reserve.

Pulse the flour, baking powder and salt to quick-sift. Remove and reserve. Process the zest with ¼ cup of the sugar until finely chopped, about 20 to 30 seconds. Add the remaining sugar and the butter, processing until smooth. The mixture may look curdled, but do not worry. With the machine running, add the egg with the brandy and vanilla. Scrape the work bowl. Add the flour mixture, chopped white chocolate and chopped ginger. Process to incorporate, about 10 seconds. Turn out onto a lightly floured surface and gather into a ball. Divide into 3 equal portions. Shape into flat logs, about 12 inches long and 1½ inches wide. Arrange on ungreased baking sheets and bake in a preheated 325°F oven for about 25 minutes.

Remove from the oven and let cool on the baking sheets for 10 minutes. Using a serrated knife, slice the logs at ½-inch intervals. Arrange on the baking sheet, so that the cut sides are exposed. Return to the oven and bake for another 20 to 25 minutes, until the biscotti are just beginning to turn golden and crispy. Allow to cool completely to finish the drying process. Store in an airtight container.

*Nutritional information per biscotti:*

*Calories 48 (46% from fat) • carb. 6g • pro. 1g • fat 2g • sat. fat 1g  
• chol. 11mg • sod. 21g • calc. 5mg • fiber 1g*

## Toffee Brownies

These sinfully delicious brownies just melt in your mouth.

Makes 16 brownies

**nonstick cooking spray**

- 2½ ounces unsweetened baking chocolate, broken into 1-inch pieces**
- 1⅓ cups granulated sugar**
- 10 tablespoons unsalted butter, melted and cooled until warm, not hot**
- 3 large eggs**
- 1½ teaspoons pure vanilla extract**
- ⅔ cup unbleached, all-purpose flour**
- 1 cup almond toffee bits (such as Heath® brand)**

Preheat oven to 350°F. Lightly coat a 9 x 9-inch baking pan with nonstick cooking spray. Cut and fold a sheet of aluminum foil so that it is 15 x 9 inches. Line pan with the foil, allowing two sides to overlap pan for easy removal from pan. Lightly coat foil lining with vegetable oil cooking spray.

Insert metal blade. Process chocolate until coarsely chopped, about 20 to 25 seconds. Add sugar and process until chocolate is as fine as the sugar, about 45 seconds. With

unit running, pour melted butter through the small feed tube and process until blended, about 20 to 25 seconds. Scrape work bowl. Add eggs and vanilla; process until fluffy and light, about 10 to 15 seconds. Add flour and toffee bits; pulse until just combined, about 5 to 6 times. Do not overprocess. Spread in prepared pan. Bake until top of brownies looks set and a toothpick inserted in the center comes out almost clean, about 30 to 35 minutes. (Due to the fudgy nature of the brownies, the toothpick will not be completely clean.) Cool in pan for 15 minutes. Use foil overhangs to remove from pan and allow to cool completely before slicing. Cut into 16 squares.

*Nutritional information per brownie:*

*Calories 236 (52% from fat) • carb. 26g • pro. 2g • fat 14g • sat. fat 1g  
• chol. 59mg • sod. 62mg • calc. 21mg • fiber 0g*

## Double Chocolate Chunk Cookies

Chocolate heaven!

Makes 36 cookies

- 5 ounces milk chocolate, chilled, broken into 1-inch pieces**
- 5 ounces white chocolate, chilled, broken into 1-inch pieces**
- 1 1/3 cups less 1 tablespoon unbleached, all-purpose flour**
- 1/2 cup pecan halves**
- 1/2 teaspoon baking soda**
- 1/4 teaspoon table salt**
- 1 large egg**
- 1/2 cup firmly packed light brown sugar**
- 1/2 cup granulated sugar**
- 2 tablespoons lowfat milk**
- 6 tablespoons unsalted butter, room temperature**
- 1 tablespoon pure vanilla extract**

Preheat oven to 375°F.

Insert metal blade and add chocolates. Use quick pulses to coarsely chop, about 10 to 12 times. Remove and reserve. Add flour, pecans, soda and salt; process to combine; about 5 seconds. Remove and reserve.

Process egg, sugars and milk for 1 minute. Scrape work bowl. Add butter and vanilla; process for 1 minute. Scrape work bowl. Add reserved dry ingredients and pulse until combined, about 5 pulses. Add chocolate and quickly pulse in, another 5 pulses.

Drop by rounded tablespoons, about 1 inch apart, onto ungreased baking sheets. Bake until golden brown, about 10 to 12 minutes. Allow to cool on baking sheet for 10 minutes; transfer to a wire rack to finish cooling.

*Nutritional information per cookie:*

*Calories 101 (53% from fat) • carb. 10g • pro. 1g • fat 6g • sat. fat 1g  
• chol. 12mg • sod. 38mg • calc. 19mg • fiber 0g*

# Peach Melba Crisp

When these two summertime fruits are out of season, try this crisp using apples or pears with dried cherries or cranberries.

Makes 6 servings

- nonstick cooking spray**
- 1½ pounds ripe but still firm peaches, peeled, halved and pitted\***
- 4 to 6 tablespoons granulated sugar, depending on sweetness of the fruit**
- 2 tablespoons instant tapioca**
- 1½ tablespoons granulated sugar**
- 1 cup fresh (or frozen, not in syrup) raspberries**
- ⅓ cup oatmeal (regular, not instant or quick)**
- ⅓ cup sliced almonds**
- 3 tablespoons unbleached, all-purpose flour**
- ¼ cup firmly packed brown sugar**
- ½ teaspoon powdered ginger**
- ½ teaspoon ground cinnamon**
- ¼ teaspoon table salt**
- 3 tablespoons unsalted butter**

Preheat the oven to 375°F. Spray a shallow 8-cup baking dish with nonstick cooking spray. Set aside.

Insert the slicing disk. Use medium pressure to slice the peaches. Transfer to a large bowl. Add the 4-6 tablespoons of granulated sugar to taste, and the tapioca; toss gently to combine thoroughly. Transfer to the prepared baking dish and sprinkle with the raspberries.

Insert the metal blade. Use the pulse to combine the 1½ tablespoons of granulated sugar, oats, nuts, flour, brown sugar, ginger, cinnamon, salt and unsalted butter. Pulse to chop the nuts and incorporate the butter, about 10 to 15 times. Sprinkle the crumb mixture evenly over the fruit. Bake in the preheated oven for 35 to 40 minutes, until the peaches are bubbly and the topping is golden and crispy. Remove and let cool on a rack for 30 minutes before serving. Serve with whipped cream and vanilla ice cream.

\*To peel peaches, cut a small “x” in the bottom of each peach. Blanch peaches in boiling water for 30 seconds, and then plunge immediately into ice cold water. The skins should slip off easily.

*Nutritional information per serving:*

*Calories 292 (30% from fat) • carb. 50g • pro. 4g • fat 10g • sat. fat 1g  
• chol. 15mg • sod. 118mg • calc. 81mg • fiber 4g*

# Apple Kuchen

This apple cake is also delightful when served for breakfast, brunch or coffee.

Makes 8 servings

- 6 ounces dried apricots**
- ½ cup plus 2 tablespoons water**  
**nonstick cooking spray**
- 2 large Granny Smith or Golden Delicious Apples,**  
**peeled, cored and halved**  
**juice of ½ lemon**
- 1 cup unbleached, all-purpose flour**
- ⅓ cup slivered almonds, lightly toasted**
- 1 teaspoon baking powder**
- ⅛ teaspoon salt**
- 2 tablespoons unsalted butter, at room temperature**
- ½ cup plus 2 tablespoons granulated sugar**
- 1 large egg**
- 1½ teaspoons pure vanilla extract**
- ¼ teaspoon almond extract**
- ⅓ cup lowfat sour cream**
- 1½ teaspoons ground cinnamon**
- 1½ tablespoons melted butter**

Bring the water to the boil in a saucepan or in the microwave. Add the apricots, return to the boil, then let sit until cool, about 20 to 30 minutes. Insert the metal blade. Purée the apricots and their cooking liquid until smooth, 4 to 5 minutes, stop the machine and scrape the work bowl 2 or 3 times. Remove and reserve.\*

Preheat the oven to 350° F. Spray a 7x10-inch baking pan with nonstick cooking spray.

Insert the slicing disc. Arrange the apples in the feed tube so that the bottom of the apple is sitting on the blade. Use medium pressure to slice. Toss the sliced apples gently with the lemon juice. Set aside.

Pulse the flour, almonds, baking powder and salt until the nuts are roughly chopped, 10 to 12 times. Remove and reserve. Cream the butter, sugar, 3 tablespoons of the apricot purée, the vanilla and almond extracts until smooth, 45 seconds. Add egg and sour cream, process 30 seconds. Scrape the work bowl, process 15 seconds longer. Add the reserved dry ingredients and pulse just to incorporate, 10 to 12 times. Do not overprocess. The batter will be thick. Spread the batter evenly in the two prepared baking pans. Arrange the apples over the batter, 3 rows of 12 overlapping apple slices in each pan (for a nice effect, arrange the middle row in the opposite direction). Combine the cinnamon and sugar, sprinkle evenly over the apples. Drizzle with the melted butter. Bake in the preheated 350° oven to 45 to 50 minutes, until a cake tester comes out clean when inserted in the middle of the pan, and the sides of the cake pull away from the pan. Cool on a rack for 30 minutes before serving. May be made a day ahead. Remove from the pans when completely cool and wrap well. May also be frozen.

\*This will yield 1 cup of apricot purée, enough to make this recipe 5 times. Leftover purée can be covered and refrigerated for 2 weeks, or frozen. Fruit purée may be substituted for part of the fat in many cake, brownie and cookie recipes. Do not remove all the fat or the product will be dry and tough.

*Nutritional information per serving:*

*Calories 312 (34% from fat) • carb. 46g • pro. 6g • fat 12g • sat. fat 4g  
• chol. 43mg • sod. 95mg • calc. 69mg • fiber 8g*

## Basic Cheesecake

*Creamy, smooth and simple to prepare.*

*Chocoholics will love the double chocolate variation.*

Makes 6 servings

- 3 lowfat honey graham crackers, broken into pieces**
- 1 tablespoon granulated sugar**
- 1 tablespoon unsalted butter**
- 1 pound lowfat cream cheese, at room temperature**
- ½ cup granulated sugar**
- 1 tablespoon pure vanilla extract**
- 2 large eggs, at room temperature**

Preheat the oven to 325°F.

Wrap the bottom and sides of a 7x3-inch springform pan in a sheet of oversized aluminum foil. There should be no seams in the foil, and it should come up to the top of the pan. Cut off any excess. Insert the metal blade. Process the graham crackers until they are fine crumbs, add the sugar and the butter through the feed tube, and process until the butter can no longer be seen. Press into the bottom of the prepared pan. Put in the freezer until ready to fill.

Wipe out the work bowl with a paper towel. Insert the metal blade. Process the cream cheese until smooth, about 20 to 30 seconds. Add the sugar and vanilla through the feed tube and process until smooth, about 30 seconds. Scrape down the sides of the work bowl. With the machine running, add one egg, process to incorporate, about 5 to 10 seconds, scrape down the sides of the work bowl. Add the second egg, process to incorporate, 5 to 10 seconds, scrape the work bowl, process for 5 seconds longer. Do not overprocess.

Carefully pour the cream cheese mixture into the prepared pan. Place in a roasting pan, and set on the rack of the oven. Carefully add hot water to the roasting pan until it reaches halfway up the sides of the springform pan. This is called a *bain marie* or water bath. Bake the cheesecake in the preheated oven for 60 minutes. The cheesecake will still look jiggly in the center. Do not worry.

Remove the cheesecake from the *bain marie*, remove the foil and place on a rack. Cool completely on a rack, then cover and refrigerate for at least 8 hours.

The cheesecake is best made a day ahead. If desired, garnish with fresh fruit.

*Nutritional information per serving:*

*Calories 287 (52% from fat) • carb. 25g • pro. 10g • fat 17g • sat. fat 9g  
• chol. 103mg • sod. 459mg • calc. 96 mg • fiber 0g*

## Double Chocolate Variation:

Before making the cheesecake, chop 5 ounces of good quality bittersweet or semisweet chocolate that has been broken up using the metal blade and pulse 20 to 30 times until roughly chopped and the chunks are not bigger than ½ inch. Melt 3 ounces in a double boiler set over barely simmering water.

Prepare the cheesecake batter, and pour 1⅓ cups into a bowl. Add the melted chocolate to the batter and process just to incorporate. Pour into the prepared pan and freeze until just firm, 2 to 3 hours. Stir the remaining chocolate chunks into the reserved batter. Pour over the frozen chocolate layer. Bake as instructed, but increase the baking time to 75 minutes.

## Basic Flaky Pastry Dough

This recipe makes ample crust for a 9- to 11-inch regular or deep-dish pie or tart. Leftover pastry may be rolled out and cut into shapes to garnish the pie, or brushed with milk, sprinkled with sugar or cinnamon and sugar, and baked until lightly browned.

### For a one-crust pie:

- 1½ cups unbleached, all-purpose flour**
- ¼ teaspoon table salt**
- ⅛ teaspoon baking powder**
- 8 tablespoons unsalted butter, cut into ½-inch pieces, well chilled**
- 2 tablespoons shortening (Crisco), cut into ½-inch pieces, well chilled**
- 2 to 4 tablespoons ice water**

### For a two-crust pie:

- 3 cups unbleached, all-purpose flour**
- ½ teaspoon table salt**
- ¼ teaspoon baking powder**
- 16 tablespoons unsalted butter, cut into ½-inch pieces, well chilled**
- 2 tablespoons shortening (Crisco), cut into ½-inch pieces, well chilled**
- 5 to 8 tablespoons ice water**

Insert the metal blade. Process the flour, salt and baking powder to sift, 10 seconds. Add the well-chilled butter and shortening. Use short rapid pulses until the mixture resembles coarse cornmeal and no pieces of butter larger than a pea remain visible, 15 to 20 pulses. Sprinkle half the maximum ice water on the flour and butter mixture, then pulse 5 or 6 times. The dough will be crumbly, but should begin to hold together when a small amount is picked up and pressed together. Sprinkle on more water, a teaspoon (two for the two-crust recipe) at a time, with 2 to 3 quick pulses after each addition, adding just enough water for the dough to hold together easily when pressed into a ball. Add the liquid sparingly so that the dough is not sticky. Do not overprocess or the pastry will be tough, not tender and flaky.

Turn the dough out onto a lightly floured surface. Press together into a ball, then flatten into a disk about 6 inches in diameter (two disks for the two-crust recipe). Wrap in plastic wrap and refrigerate for 1 hour before continuing to allow the glutes in the flour to rest. The dough will keep refrigerated for up to 3 days, or may be frozen (double-wrapped) for up to a month, thaw at room temperature for an hour before using.

\*To bake the pastry blind for a single-crust filled pie or tart, roll out pastry ⅛-inch thick to

fit pan, crimp and seal edges. Prick bottom all over with a fork. Chill for 30 minutes. Preheat the oven to 400°F. Line with a sheet of aluminum foil or parchment paper and fill with pie weights, dry rice or beans. Bake for 15 minutes.

*Nutritional information per serving (2-crust, 12 servings):*  
Calories 252 (60% from fat) • carb. 22g • pro. 3g • fat 17g • sat. fat 10g  
• chol. 40mg • sod. 107mg • calc. 2mg fiber 1g

## Deep Dish Pear and Apple Pie

Pears and apples combine to make a delightful taste combination. If you want, you may use use all pears or all apples.

Makes a 10-inch deep dish pie /12 servings

**pastry for a 2-crust pie, page 68**

- 3 ripe but firm pears, about 8 ounces each, peeled, cored and quartered**
- juice from 1 lemon**
- ¼ cup pure maple syrup (not pancake syrup)**
- 1½ teaspoons pure vanilla extract**
- 3 Granny Smith apples, about 8 ounces each, peeled, cored and quartered**
- 4 tablespoons unbleached, all-purpose flour, divided**
- ¾ cup dried cranberries**

Preheat the oven to 400°F.

Roll out half the pastry to fit a 10-inch deep dish pie plate, leaving a ½-inch overhang. Refrigerate until ready to use.

Insert the slicing disk. Arrange the pear quarters in the feed tube. Use medium pressure to slice. Repeat until all the pears are sliced. Transfer to a bowl and toss gently with half of the lemon juice. Reserve. Arrange the apple quarters in the feed tube. Use medium pressure to slice. Transfer to a bowl and toss with the remaining lemon juice. Insert the metal blade. Process the maple syrup and vanilla to combine.

Layer half of the apples in the prepared piecrust, sprinkle with 1 tablespoon of the flour and 3 tablespoons of the dried cranberries. Top this with a layer of the pears sprinkled with 1 tablespoon of the flour and 3 tablespoons of the dried cranberries. Repeat both layers. Drizzle the maple syrup mixture evenly over the top of the fruit. Roll out the remaining pie crust about ⅛-inch thick to fit the pie plate. Brush the edges of the bottom crust with a little water. Carefully lay the top crust on the pie. Press gently to seal. Trim to the edge of the pie plate, crimp or flute decoratively. Make about 10 to 12 slits in the top crust decoratively with the tip of a very sharp knife. If desired, roll out some of the leftover crust and cut with small decorative cookie cutters. For this pie, you could use pears, apples and leaves. Brush the bottoms of the shapes with a little water and lay atop the crust in a decorative fashion.

Bake the pie in the bottom third of the preheated oven for 60 to 70 minutes, covering the edges with foil if they begin to get too browned after about 35 to 40 minutes. Let the pie rest on a cooling rack at least an hour before serving.

*Nutritional information per serving:*  
Calories 351 (43% from fat) • carb. 47g • pro. 4g • fat 17g • sat. fat 10g  
• chol. 40mg • sod. 108mg • calc 13mg • fiber 3g





# Cuisinart®

SAVOR THE GOOD LIFE®



Coffeemakers



Stand Mixers



Food  
Processors



Griddler



Cookware



Brick Ovens

Cuisinart offers an extensive assortment of top quality products to make life in the kitchen easier than ever. Try some of our other countertop appliances and cookware, and Savor the Good Life®.

**[www.cuisinart.com](http://www.cuisinart.com)**

©2007 Cuisinart  
Cuisinart® is a registered  
trademark of Cuisinart

150 Milford Road  
East Windsor, NJ 08520  
Printed in China

Any other trademarks or service marks referred to herein are the trademarks or service marks of their respective owners.

07CU26668

U IB-8044

Version no: DLC2009CHB IB-8044

SIZE:140 mm(W) X 216 mm(H)  
Total Pages:72pp

Material:  
Cover:157gsm matt art paper  
Inside:120gsm art paper

Coating: Varnishing

Color:Cover page/4C+Inside page/1C(BLACK)  
Cover:  
Inside:

Die cut:

Bar Code:

Date:10/18/07 (00)

Coordinator: Alice Chong

 CHUNG TAI PRINTING HOLDINGS LTD.  
中大印刷集團有限公司

Tel: 2669 6173

Fax: 2677 6556

