

advantage

MIX'N MACHINE™ ADVANCE PROGRAMMABLE

The advance performance frozen treat mixer

The new Mix'n Machine Advance is the **first-ever programmable frozen treat mixer!** Designed for versatility, the robust Mix'n Machine Advance eliminates the guesswork for operators. With one-hand operation, 6 pre-set blending programs, end-of-cycle indicator and automatic shut off, this workhorse is the most consistent and efficient mixer on the market. From mix-in treats to thick, smooth malts and milkshakes, the Mix'n Machine Advance is perfect for high-volume ice cream shops, smoothie shops and Quick-Serve Restaurants. **Advantage: Vita-Mix.**



FOODSERVICE

MIX'N MACHINE™ ADVANCE

FEATURES

- 6 optimized programs with automatic shut-off
- Red LED end-of-cycle Indicator Light
- Fully programmable (software available)
- Cup-activated Actuator Lever with “smart” delay between cycles
- Versatile Pulse Control
- Easy-to-remove protective Splash Guard
- Enclosed stainless steel shell
- Variety of efficient agitator options

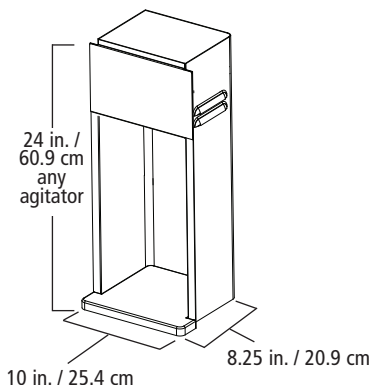
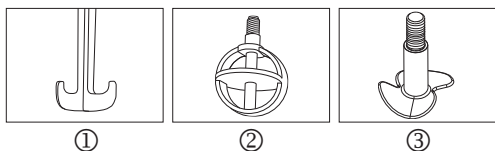

Motor: 500 RPMs to 3000 RPMs bare motor speed

Pack: 1 per standard pack

Weight: 20 lbs. / 9.1 kg

Case Dimensions: 27 in. / 68.6 cm High x

10.2 in. / 25.9 cm Wide x

12 in. / 30.5 cm Deep



Where Applicable
RoHS

For more information, contact your local foodservice dealer/distributor.



BENEFITS

- Combine the most difficult-to-blend ingredients reliably with ease and speed
- Keep customers coming back for your consistently smooth, delicious frozen treats
- Eliminate guesswork with programs designed for a variety of commonly made desserts
- Remove excess product from the agitator before cycle automatically ends
- Eliminate wasted ingredients
- Create consistent signature dessert treats every time at every location
- One-hand operation with gentle start for easy activation
- Quickly refresh treats or mix them manually for ultimate flexibility
- Reduce cleanup time
- Durable and NSF-accepted solid housing
- Removable/reusable non-metal agitator for fast clean up between servings and elimination of flavor, coloring and potential allergen transfers ①
- Non-metal permanent agitator for soft ice cream ②
- Permanent stainless steel agitator with rounded edges for efficient and aggressive hard ice cream mixing ③

MIX'N MACHINE ADVANCE PROGRAMMABLE MODELS

Pre-programmed with 6 blending programs.

Item # Description

120V, 50/60 Hz, 2 Amps

- 580 Mix'n Machine Advance with **Permanent Soft Ice Cream Agitator**, Countertop
- 581 Mix'n Machine Advance with **10 Removable/Reusable Agitators**, Countertop
- 582 Mix'n Machine Advance with **Aggressive/Permanent Hard Ice Cream Agitator**, Countertop

100V, 50/60 Hz, 100 Watts

- 25027 Mix'n Machine Advance with **Permanent Soft Ice Cream Agitator**, Countertop
- 25028 Mix'n Machine Advance with **10 Removable/Reusable Agitators**, Countertop
- 25029 Mix'n Machine Advance with **Aggressive/Permanent Hard Ice Cream Agitator**, Countertop

220V-240V, 50/60 Hz, 150-180 Watts

- 25021 Mix'n Machine Advance with **Permanent Soft Ice Cream Agitator**, Countertop
- 25022 Mix'n Machine Advance with **10 Removable/Reusable Agitators**, Countertop
- 25023 Mix'n Machine Advance with **Aggressive/Permanent Hard Ice Cream Agitator**, Countertop

WARRANTY

In the United States and Canada, the Vita-Mix Mix'n Machine Advance is backed by a three-year warranty against defects in parts and workmanship. Other warranties apply outside the United States and Canada. Contact your local Vita-Mix Distributor for details or telephone +1.440.782.2450 for a distributor near you.

www.vitamix.com/mixnmachine

800-4DRINK4



FOODSERVICE

For a Dealer near you, contact Vita-Mix:

US, Canada and Latin America: TEL: 440-235-0214;

FAX: 440-235-9670; EMAIL: foodservice@vitamix.com

For a Distributor in all other countries: TEL: +1.440.782.2450;

FAX: +1.440.782.2220; EMAIL: international@vitamix.com

mix-in frozen treats