

get started

INSTANT POT® **PRO**
MULTI-COOKER
USER MANUAL

Instant®

Welcome

to your new Instant Pot® Pro!

This Instant Pot Pro Multi-Cooker can help you cook healthy, delicious meals more easily and in less time. We hope you fall in love with Instant Pot cooking and enjoy it in your kitchen for years to come.

Get started with your new Pro!



CONTENTS

Important safeguards	2
What's in the box	7
Using your Pro	10
Initial setup	15
Using the lid	21
Pressure cook	23
Rice/Grain	26
Steam	28
Sauté	30
Slow cook	32
Sous Vide	34
Yogurt	36
Bake	39
Keep warm	41
Favorites	43
Cleaning	44
Troubleshooting	45
Error Codes	47
Replacement parts	48
Learn more	49
Warranty	50

IMPORTANT SAFEGUARDS

WARNING

Failure to follow safety instructions may result in personal injury and/or property damage and may void your warranty.

READ ALL INSTRUCTIONS

Before using your new appliance, please read all instructions, including the Safety Information below. Keep this manual for reference.

Placement

- **DO** place the appliance on a countertop only. Always operate the appliance on a stable, non-combustible, level surface.
- **DO** make sure all parts are dry and free of food debris before placing the inner cooking pot on the cooker base.
- **DO NOT** place the appliance on or close to a gas or electric burner, or oven. NEVER use the appliance on your stove.
- **DO NOT** use the appliance near water, an external heat source or flame.
- **DO NOT** use outdoors. Keep out of direct sunlight.
- **DO NOT** place on anything that may block the vents on the bottom of the appliance.

General Use

The removable inner cooking pot is extremely hot during use and can be extremely heavy when full of ingredients.

- **DO** use oven mitts when handling the inner cooking pot and removing accessories.
- **DO** place hot accessories on a heat-resistant surface or cooking plate.
- **DO** use care when lifting the cooking pot from the cooker base to avoid burn injury.
- **DO** use extreme caution when the cooking pot contains hot food, hot oil or other hot liquids.
- **DO** use only the Instant Pot lid that came with this cooker base. Using any other pressure cooker lids may cause personal injury and/or property damage.

⚠ WARNING

Failure to follow safety instructions may result in personal injury and/or property damage and may void your warranty.

- **DO NOT** use the appliance without the removable inner cooking pot installed.
- **DO NOT** touch the appliance's hot surfaces, or any accessories during or immediately after cooking because they will be hot. Only use the appliance's side handles for carrying or moving.
- **DO NOT** use this appliance for deep frying or pressure frying with oil.
- **DO NOT** move the appliance while it is in use and use extreme caution when disposing of hot grease.
- **DO NOT** allow children or persons with reduced physical, sensory or mental capabilities to operate this appliance. Close supervision is necessary when any appliance is used by or near children and persons with reduced physical, sensory or mental capabilities. Children should not play with this appliance.
- **DO NOT** use the appliance for anything other than household use. It is not intended for commercial use.
- **DO NOT** leave the appliance unattended while in use.

Pressure Cooking

This appliance cooks under pressure. Allow the appliance to depressurize naturally or release all excess pressure before opening.

Failure to follow these instructions may result in burns, personal injury and/or property damage.

- **DO** make sure the appliance is properly closed before operating.
- **DO** check that the steam release valve is installed properly.
- **DO** use the pressure cooking lid when pressure cooking.
- **DO** turn the appliance off if steam escapes from the steam release valve and/or float valve in a steady stream for longer than 3 minutes. If steam escapes from the sides of the lid, turn the appliance off. Once steam stops, pressure is released and the cooker has cooled, carefully make sure the sealing ring is properly installed.
- **DO** ensure the sealing ring is in good condition and installed properly.
- **DO** check the steam release valve, steam release pipe, anti-block shield and float valve for clogging before use.
- **DO NOT** remove the pressure cooking lid with unprotected hands.

⚠ WARNING

Failure to follow safety instructions may result in personal injury and/or property damage and may void your warranty.

- **DO NOT** attempt to force the lid off the Instant Pot cooker base.
- **DO NOT** move the appliance when it is pressurized.
- **DO NOT** cover or obstruct the steam release valve and/or float valve with cloth or other objects.
- **DO NOT** attempt to open the appliance until it has depressurized, and all internal pressure has been released. Attempting to open the appliance while it is still pressurized may lead to sudden release of hot contents and may cause burns, personal injury and/or property damage.
- **DO NOT** place your face, hands or exposed skin over the steam release valve or float valve when the appliance is in operation or has residual pressure, and do not lean over the appliance when removing the lid.

Overfill During Pressure Cooking

Overfilling may cause a risk of clogging the steam release pipe and valve, developing excess pressure.

- **DO NOT** fill the inner cooking pot over the line labeled 'PC MAX' or 'Max PC Fill'.
- **DO NOT** fill the inner cooking pot over the line labeled '1/2' when cooking foods that expand during cooking such as rice, dried beans or dried vegetables.
- **DO** be aware that certain foods, such as applesauce, cranberries, pearl barley, oatmeal or other cereals, split peas, noodles, macaroni, rhubarb, or spaghetti can foam, froth and sputter, and clog the steam release pipe and valve. **DO NOT** fill the inner cooking pot over the line labeled '1/2' when cooking these foods.
- **DO NOT** place oversized foods into the inner cooking pot as they may cause risk of fire, personal injury and/or property damage.
- **DO** check that sealing ring is properly installed.

Accessories

- **DO** use only accessories or attachments authorized by Instant Brands. The use of parts, accessories or attachments not recommended by the manufacturer may cause a risk of electric shock or other personal injury, fire and/or property damage.

⚠ WARNING

Failure to follow safety instructions may result in personal injury and/or property damage and may void your warranty.

- **DO** use only an authorized Instant Pot inner cooking pot to reduce the risk of pressure leakage.
- **DO** only replace the sealing ring with an authorized Instant Pot sealing ring to prevent personal injury, property damage, and/or damage to the appliance.
- **DO NOT** use the included accessories in a microwave, toaster oven, convection or conventional oven, or on a ceramic cooktop, electric coil, gas range or outdoor grill.

Care and Storage

- **DO** let the appliance cool to room temperature before cleaning or storage.
- **DO NOT** store any materials, other than the inner cooking pot, in the cooker base when not in use.
- **DO NOT** place any combustible materials in the cooker base, such as paper, cardboard, plastic, Styrofoam or wood.

Power Cord

A short power-supply cord is used to reduce the hazards resulting from grabbing, entanglement or tripping. **WARNING:** Hot spilled food can cause serious burns.

- **DO** keep appliance and power cord away from children.
- **DO NOT** let the power cord hang over edges of tables or counters.
- **DO NOT** let the power cord touch hot surfaces or open flame, including a stovetop.
- **DO NOT** use below-counter power outlets.

This appliance has a 3-prong grounding plug. To reduce the risk of electric shock:

- **ONLY** plug the power cord into a grounded electrical outlet.
- **DO NOT** remove the grounding prong on the electrical plug.
- **DO NOT** use with extension cords, power converters or adapters, timer switches or separate remote-control systems.

⚠ WARNING

If the unit includes a detachable power cord:

- To connect, always attach the power cord to the appliance first, then plug the power cord into the wall outlet.

Electrical Cautions

The cooker base contains electrical components that are an electrical shock hazard. **Failure to follow these instructions may result in electric shock and/or death.**

To protect against electrical shock:

- To disconnect, select Cancel, then remove plug from power source. Always unplug when not in use, as well as before adding or removing parts or accessories, and before cleaning. To unplug, grasp the plug and pull from the outlet. NEVER pull from the power cord.
- **DO** regularly inspect the appliance and power cord.
- **DO NOT** operate the appliance if the power cord or plug is damaged, or after the appliance malfunctions or is dropped or damaged in any manner. For assistance, contact Consumer Care by email at **support@instanthome.com**.
- **DO NOT** attempt to repair, replace or modify components of the appliance, as this may cause electric shock or other personal injury, fire and/or property damage, and will void the warranty. For assistance, contact Consumer Care by email at **support@instanthome.com**.
- **DO NOT** tamper with any of the safety mechanisms, as this may result in personal injury and/or property damage.
- **DO NOT** put liquid or food of any kind into cooker base. Always place food into the inner cooking pot and place the cooking pot into the cooker base.
- **DO NOT** immerse the power cord, plug or appliance in water or other liquid.
- **DO NOT** clean the appliance by rinsing it under a faucet.
- **DO NOT** use the appliance in electrical systems other than 120 V ~ 60 Hz for North America.

SAVE THESE INSTRUCTIONS

⚠ WARNING

Failure to adhere to safety instructions may result in personal injury and/or property damage and may void your warranty.

WHAT'S IN THE BOX

Lid

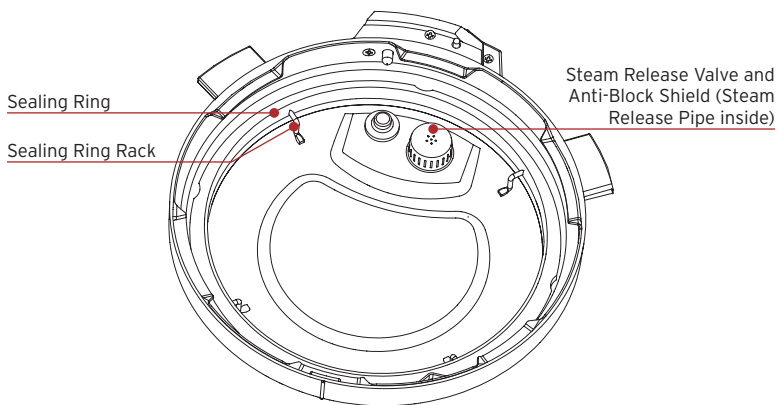
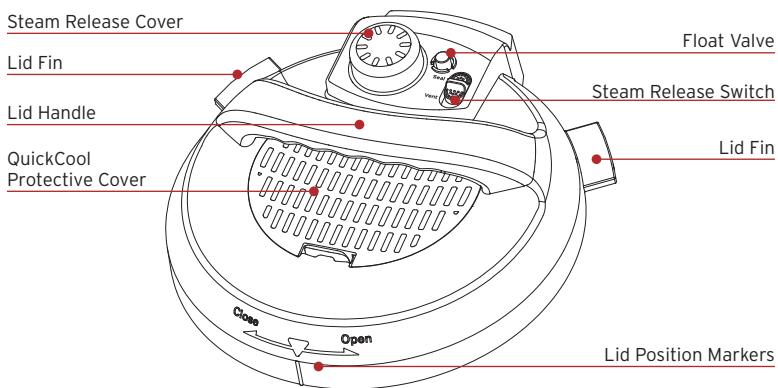

Illustrations are for reference only and may differ from the actual product.

Stainless Steel Inner Cooking Pot

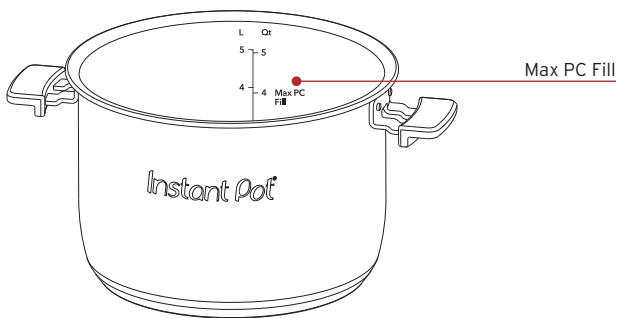

Cooker Base

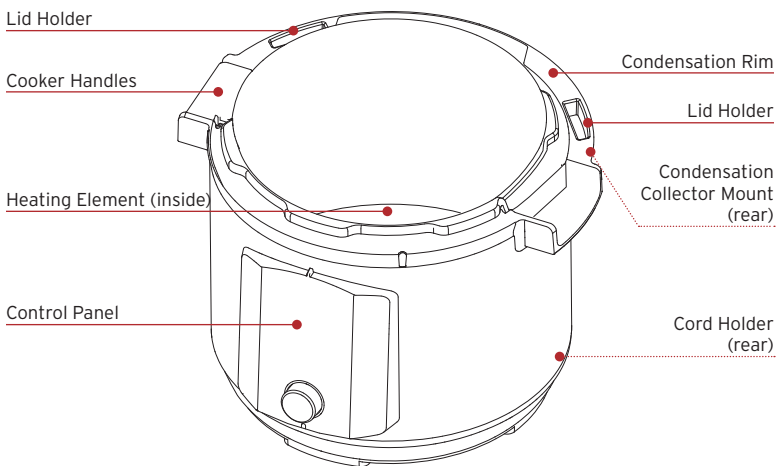

Illustrations are for reference only and may differ from the actual product.

Accessories

Steam Rack

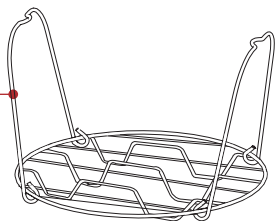

Extra Sealing Ring

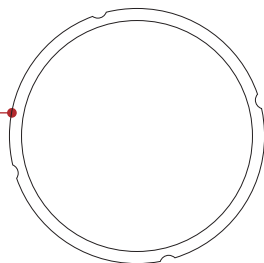

Condensation Collector

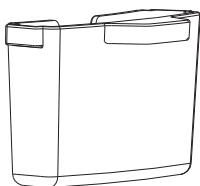

Remember to recycle!

We designed this packaging with sustainability in mind. Please recycle everything that can be recycled where you live.

USING YOUR PRO

Control panel

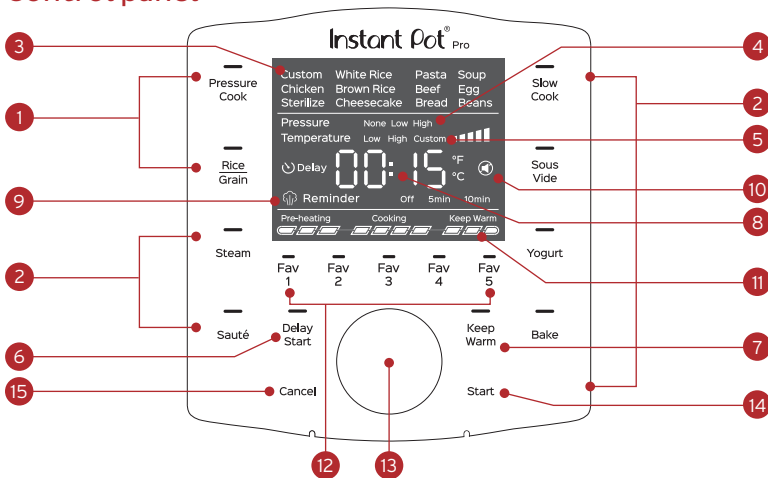

1. Pressure Cooking Smart Programs
Light shows the active Smart Program
2. Non-Pressure Cooking Smart Programs
Light shows the active Smart Program
3. Smart Program Preset Cooking Options
4. Pressure
Low or High or None
5. Temperature
Low or High or Custom
6. Delay Start
Can also serve as Kitchen Timer
7. Keep Warm
On or Off
8. Time Display
*Cook time countdown
Keep Warm count
Choose Fahrenheit or Celsius*
9. Vent Reminder
For pressure cooking
10. Sounds
On or Off
11. Cooking Progress Bar
See page 12
12. Favorites
One-touch access to saved programs
13. Control Dial
*Choose Smart Programs
Adjust time, temperature, pressure*
14. Start
15. Cancel
Stop cooking at any time

Cooking Progress Bar



Preheating: cooker is heating to the set temperature and pressure is building on pressure programs. Display shows **On**.

Cooking: cooker has started the Smart Program. Display counts down cooking time.

Keep Warm: turns on automatically after cooking stops. When done, display shows **End**.

Status messages

The control panel shows information you need to know when using your Instant Pot Pro.

OFF	Standby mode
On	Preheat mode
Hot	Sauté Smart Program is ready to add food
05:20	Time <ul style="list-style-type: none">• Smart Program: cooking time remaining• Delay Start: time until Smart Program starts• Keep Warm: time food has been warming
boil	Yogurt Smart Program is in pasteurizing cycle
SET2	You've selected a Favorites program
Not SET	You've pressed a Fav key that hasn't been saved
End	Smart Program ended (Keep Warm is off)

Turning the sound On/Off

You set the alert sounds to either ON or OFF.

1. When in Standby mode, press and hold the dial for 5 seconds.
2. Press the dial again to display the current sound settings.
3. Turn the dial until the display shows **S On** or **SOFF**.
4. Press **Start** to save the new setting.

Audible safety alerts (beeps) cannot be turned off.

Choosing the temperature scale

You can choose to show cooking temperature in either Fahrenheit or Celsius.

1. When in Standby mode, press and hold the dial for 5 seconds.
2. Turn the dial until the display shows **°F** or **°C**.
3. Press the dial twice to set the sound.
4. Press **Start** to save the new setting.

Cooking temperature will now show in the scale you chose.

Delay the start of cooking

You can set a Delay Start timer for a minimum of 10 minutes or a maximum of 24 hours.

1. Select a Smart Program and adjust the settings, then press **Delay Start**.
2. The hours and minutes fields will begin flashing. Use the **Control Dial** to adjust the delay time. Then press **Start**.
3. Delay Start begins and the timer starts counting down.
4. When Delay Start ends, the selected Smart Program begins and the display indicates **On**.

Delay Start is not available with the Sauté or Yogurt Smart Programs.

Set a timer (without cooking)

You can set a timer for a minimum of 1 minute or a maximum of 60 minutes.

1. When the unit is on and the message display shows **OFF**, press **Delay Start**.
2. Turn the **Control Dial** to set the time (in 1 minute increments).
3. Press **Start** to begin the timer. You can press **Cancel** to stop the timer.

Cancel cooking

When in Preheating, Cooking or Keep Warm modes, press **Cancel**. The message display shows **OFF**.

Reset Smart Programs to original settings

Reset Individual Smart Programs

- With the cooker in Standby mode, press and hold one Smart Program button until the cooker returns to Standby and shows **OFF**.

The Smart Program's pressure level, cooking time and temperature are restored to the factory default setting.

Reset All Smart Programs

- With the cooker in Standby mode, press and hold **Cancel** until the cooker beeps.

All Smart Program pressure levels, cooking times and temperatures are restored to the factory default setting.

INITIAL SETUP

Clean before use

1. Wash the inner cooking pot with hot water and soap. Rinse and use a soft cloth to dry the outside. Or you can wash the inner cooking pot in the dishwasher
2. Wipe the heating element inside the cooker base with a soft cloth to ensure there are no stray packaging particles.

Setting up the condensation collector

The condensation collector sits at the back of the cooker base and accumulates overflow moisture from the condensation rim. It should be installed before cooking, then emptied and rinsed out after each use.

Remove the condensation collector

Pull the condensation collector away from the cooker base; do not pull down.

Note the tabs on the cooker base and the grooves on the condensation collector.

Install the condensation collector

Align the grooves on the condensation collector with the tabs on the back of the cooker base and slide the condensation collector into place.

Using the Sealing Ring

When the pressure cooking lid is closed, the sealing ring installed on the underside of the lid creates an air-tight seal between the lid and the cooker base.

- The sealing ring **MUST** be properly installed before using the cooker and should be cleaned after each use.
- Install 1 sealing ring at a time; use one for sweet dishes and one for savory.
- Sealing rings stretch over time with normal use. To keep your product safe, **replace the sealing ring every 12 to 18 months**. Replace sooner if you notice stretching, deformation, or damage.

Install the Sealing Ring

1. Place the sealing ring behind the sealing ring rack and press it into place. Press down firmly to ensure there is no puckering.
2. The sealing ring should be snug and should not fall out when the lid is turned over.

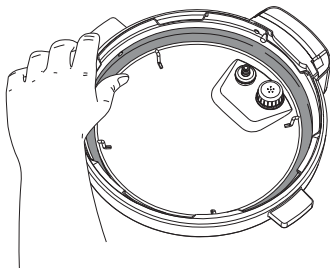

Remove the Sealing Ring

1. Grip the edge of the sealing ring and pull it out from behind the sealing ring rack.
2. Inspect the rack to ensure it is secured, centered, and at an even height all the way around the lid. If the sealing ring rack is deformed, do not try to repair it.

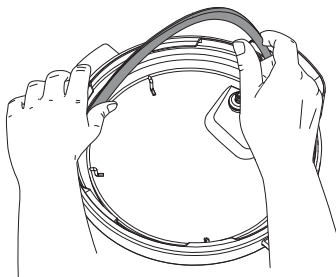

⚠ WARNING

Failure to adhere to safety instructions may result in personal injury and/or property damage and may void your warranty.

Using the float valve

The float valve shows whether there is pressure in the cooker (pressurized) or not (depressurized).

Visibly popped up above the surface of the lid.

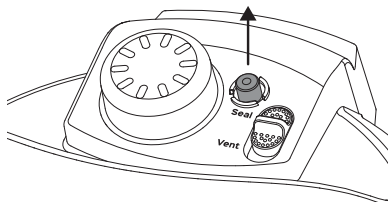

Pressurized

Descended, with the top flush with the lid.

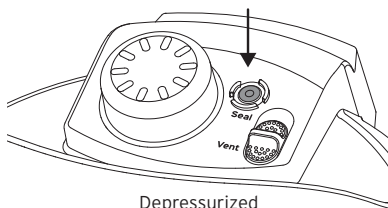

Depressurized

Anti-block shield

The anti-block shield prevents food particles from coming up through the steam release pipe, helping to regulate pressure.

As an integral part of product safety, the anti-block shield must be installed before use and cleaned frequently.

Remove the Anti-Block Shield

Grip the lid like a steering wheel and use your thumbs to press firmly against the side of the anti-block shield (pressing towards the side of the lid and up) until it pops off the prongs underneath.

Install the Anti-Block Shield

Place anti-block shield over prongs and press down until it snaps into position. Do not attempt to operate the pressure cooker without the anti-block shield installed.

Using the steam release valve

When the cooker releases pressure, steam ejects from the top of the steam release valve. The steam release valve is integral to product safety and necessary for pressure cooking. It must be installed before use and cleaned regularly.

! WARNING

If the steam release valve is not installed, hot liquid will spatter out, which may lead to personal injury or property damage.

Remove the Steam Release Valve

Pull steam release valve up and off steam release pipe.

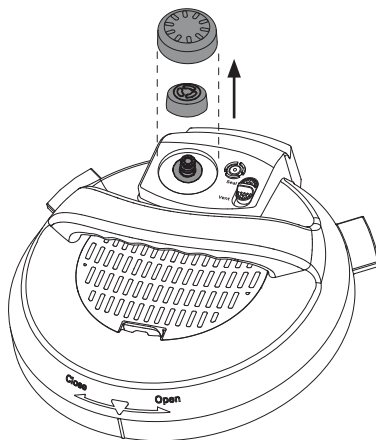

Install the Steam Release Valve

Place the steam release valve on the steam release pipe and press down firmly.

When installed properly, the steam release valve sits loosely on the steam release pipe. It should remain in place when the lid is turned over.

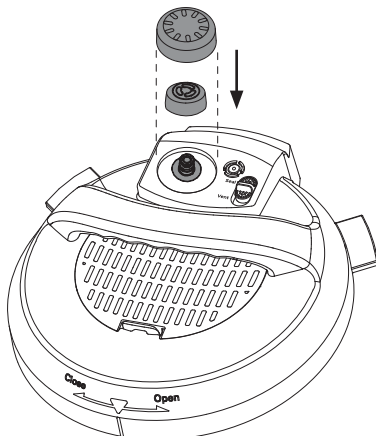

Note: 6QT and 8QT model has electrical cord that is always connected to the unit.

Test run

Setting up your new Instant Pot Pro for a test run is a great way to familiarize yourself with how the unit works before you actually cook a meal.

To perform a test run:

1. Add 3 cups water to the inner cooking pot.
2. Place the inner cooking pot into the cooker base.
3. Place the lid on top of the cooker base and lock the lid.
See 'How to close and lock the lid' below
4. Press **Pressure Cook** on the Control Panel.
5. Press the **Control Dial**, then turn the **Control Dial** to set the cooking time to 5 minutes.
6. Press **Keep Warm** to turn off the Keep Warm setting.
7. Press **Start** to begin. The message display shows **Preheating**.
8. When cooking is done, the display shows **End**.
9. Release steam by moving the steam release to the Vent position.
See 'How to release steam' on page 22 for complete instructions
10. Unlock and open the lid after all steam has been completely released.
See 'How to unlock and open the lid' below
11. Discard any remaining water, and then wash and dry the inner cooking pot.

Now you're ready to cook a meal in your Instant Pot Pro!

USING THE LID

You'll use the pressure cooking lid for most cooking programs, and especially for pressure cooking. Always use the pressure cooking lid that came with this Instant Pot Pro cooker base.

How to close and lock the lid

For pressure cooking, the lid must be securely locked into place to prevent steam from escaping. When you place the lid on the cooker base:

1. Line up line on the lid with the arrow at the side of the control panel.
2. Turn the lid clockwise until the line on the lid lines up with the line on the control panel.

If the lid is not closed and locked when you start a cooking program, the message display will show Turn to Lock Lid and the unit will not start pressurizing.

How to unlock and open the lid

Once steam is completely released, you must unlock the lid before opening it:

1. Turn the lid counterclockwise until the line on the lid lines up with the arrow on the side of the control panel.
2. Carefully lift the lid up and off the cooker base.

When a cooking program is finished and steam has been released, the steam icon on the display will disappear and the message display will show END and OK to Open Lid.

How to release steam

Instant Pot Pro can release steam in 2 different ways. Use the one that best fits the type of food you're cooking.

Natural steam release

Releases steam gradually over time (up to 40 minutes or more) as after cooking stops.

Use for: Foods that can simmer, like stews, chili, pasta, oatmeal, beans and grains.

1. After cooking, leave steam release switch in **Seal** position until all pressure is released.
2. Float valve drops into lid when all steam is released.
3. After steam release, turn lid counterclockwise and remove the lid.

Quick steam release

Quickly releases steam after you press the steam release switch.

Use for: Foods that tend to overcook, like vegetables and seafood.

1. After cooking, set steam release switch to **Vent** position and wait for all pressure to release
2. Float valve drops into lid when all steam is released.
3. After steam release, turn lid counterclockwise and remove the lid.

You can insert the lid fin into the cooking base vertically for easy storage.

⚠ CAUTION

This appliance uses pressure to cook. Allow the appliance to release all excess pressure and steam before opening the lid. Opening the lid before pressure is released may result in burns, personal injury and/or property damage. Read more in the Safety, Maintenance and Warranty document.

PRESSURE COOK

Pressure cooking uses pressurized steam to quickly and evenly cook foods. Each specific Smart Program is designed to pressure cook a specific type of food. You can adjust the settings as your recipe directs.

Choose from these settings in the Pressure Cook Smart Program:

Program	Default Cook Time	Min Cook Time	Max Cook Time	Default Pressure Level
Custom	10 minutes (00:10)	1 minute (00:01)	8 hours (00:00)	High
Pasta	1 minute (00:01)	1 minute (00:01)	1 hour (01:00)	High
Soup	30 minutes (00:30)	1 minute (00:01)	4 hours (04:00)	High
Chicken	10 minutes (00:10)	1 minute (00:01)	4 hours (04:00)	High
Beef	30 minutes (00:30)	1 minute (00:01)	4 hours (04:00)	High
Beans	20 minutes (00:20)	1 minute (00:01)	4 hours (04:00)	High
Egg	5 minutes (00:05)	1 minute (00:01)	10 minutes (00:10)	High
Sterilize	10 minutes (00:10)	1 minute (00:01)	30 minutes (00:30)	High

Other settings

- Automatic Keep Warm is set to ON by default for all Pressure Cook programs.
- Delay Start is available for all Pressure Cook programs.

How to pressure cook

Prep

Cut, chop, season or marinate your ingredients according to your recipe.

Preheat

1. Place the inner cooking pot into the cooker base and add ingredients.
2. Place the lid on top of the cooker base and lock the lid.
3. Choose **Pressure Cook** on the Control Panel, then press the **Control Dial** to select it.
4. The default pressure level flashes. To select it, press the **Control Dial**. Or to change it, turn the **Control Dial** until the one you want flashes, then press the dial to select it.
5. The default cooking time flashes. To select it, press the **Control Dial**. Or turn the **Control Dial** to change it, then press the dial to select it.
6. The vent reminder flashes. To keep it on, press the **Control Dial**. Or to change it, turn the **Control Dial** to turn it off, then press the dial to select it.
7. Press **Start**. The **Progress Bar** shows **Preheating** (the display shows On) and the Instant Pot Pro starts building pressure.
8. Keep Warm setting is ON by default. Press **Keep Warm** at any time to turn it off.

It can take up to 30 minutes to reach the pressure setting for cooking. Frozen foods increase the preheating time.

The pressure level and time you choose will be the new settings the next time you use that Smart Program.

Cook

1. When the pressure is ready, the Instant Pot Pro starts cooking.
2. The cooking timer starts counting down.

You can press Cancel to stop cooking and cancel the Smart Program at any time.

Stop cooking

1. When the timer reaches 00:00, cooking stops.
2. If Keep Warm is ON, the timer starts counting up.

Release steam

Choose from the steam release method that works for your recipe.

See 'How to release steam' for full details.

Using liquid to create steam

Pressure cooking requires liquid in the inner cooking pot to produce the steam needed. Depending on the size of your Instant Pot Pro, here are the minimum amounts you'll need:

Instant Pot Size	Minimum Liquid for Pressure Cooking*
6 Quarts / 5.7 Litres	1 1/2 cups (12 oz / 375 mL)
8 Quarts / 7.6 Litres	2 cups (16 oz / 500 mL)

Pressure cooking liquids should be water-based, such as broth, stock, soup or juice. If using canned, condensed, or cream-based soup, add water as directed above.

RICE/GRAIN

The Rice program uses pressurized steam to cook rice quickly and evenly. You can adjust the settings as your recipe directs.

Choose from these settings in the Rice Smart Program:

Program	Pressure	Default Cook Time	Min Cook Time	Max Cook Time
Custom	Low	12 minutes (00:12)	1 minute (00:01)	1 hour (01:00)
Brown Rice	High	30 minutes (00:30)	1 minute (00:01)	1 hour (01:00)
White Rice	Low	12 minutes (00:12)	1 minute (00:01)	30 minutes (00:30)

Other settings

- Automatic Keep Warm is set to ON by default for all Rice/Grain programs.
- Delay Start is available for all Rice/Grain programs.

How to cook rice

Prep

Cut, chop, season or marinate your ingredients according to your recipe.

Preheat

1. Place the inner cooking pot into the cooker base and add ingredients.
2. Place the lid on top of the cooker base and lock the lid.
3. Choose **Rice/Grain** on the Control Panel, then press the **Control Dial** to select it.

4. The default pressure level flashes. To select it, press the **Control Dial**. Or to change it, turn the **Control Dial** until the one you want flashes, then press the dial to select it.
5. The default cooking time flashes. To select it, press the **Control Dial**. Or turn the **Control Dial** to change it, then press the dial to select it.
6. The vent reminder flashes. To keep it on, press the **Control Dial**. Or to change it, turn the **Control Dial** to turn it off, then press the dial to select it.
7. Press **Start**. The Progress Bar shows **Preheating** (the display shows **On**) and the Instant Pot Pro starts building pressure.
8. Keep Warm setting is ON by default. Press **Keep Warm** at any time to turn it off.

It can take up to 30 minutes to reach the pressure setting for cooking. Frozen foods increase the preheating time.

The pressure level and time you choose will be the new settings the next time you use that Smart Program.

Cook

1. When the pressure is ready, the Instant Pot Pro starts cooking.
2. The cooking timer starts counting down.

You can press Cancel to stop cooking and cancel the Smart Program at any time.

Stop cooking

1. When the timer reaches 00:00, cooking stops.
2. If Keep Warm is ON, the timer starts counting up.

Release steam

Choose from the steam release method that works for your recipe.

See 'How to release steam' for full details.

STEAM

Use Steam as you would a regular stovetop steamer, boiling liquid to cook food with hot steam, or as a sanitization chamber for glass and plastics. The Steam program does not use pressure to cook.

Refer to the glass or plastic manufacturer's instructions for the time needed for sanitization.

Choose from these settings in the Steam Smart Program:

Program	Temperature	Default Cook Time	Min Cook Time	Max Cook Time
Custom	Low or High	30 minutes (00:30)	1 minute (00:01)	1 hour (01:00)

Other settings

- Automatic Keep Warm is not available.
- Delay Start is not available.

How to steam

Prep

Cut or chop your ingredients according to your recipe.

Preheat

1. Place the inner cooking pot into the cooker base.
2. Place the steam rack inside the cooking pot and add ingredients.
3. Place the lid on top of the cooker base and lock the lid.

If you want to watch the food as you cook, you can use any glass lid with a steam vent.

4. Choose **Steam** on the Control Panel, then press the **Control Dial** to select it.

5. The default cooking temperature flashes. To select it, press the **Control Dial**. Or to change it, turn the **Control Dial** until the one you want flashes, then press the dial to select it.
6. The default cooking time flashes. To select it, press the **Control Dial**. Or to change it, turn the **Control Dial** to change it.
7. Press **Start**. The Progress Bar shows **Preheating** (the display shows **On**).

The cooking temperature and time you choose will be the new settings the next time you use that Smart Program.

Cook

1. The cooking timer starts counting down.

You can press Cancel to stop cooking and cancel the Smart Program at any time.

Stop cooking

1. When the timer reaches 00:00, cooking stops.

SAUTÉ

Use Sauté in place of a frying or saucepan. Sautéing can deepen the flavors of your food, or can simmer, thicken or reduce sauces.

Choose from these settings in the Sauté Smart Program:

Program	Temperature	Default Cook Time	Min Cook Time	Max Cook Time
Custom	Low, High or Custom	30 minutes (00:30)	1 minute (00:01)	1 hour (01:00)

Other settings

- Automatic Keep Warm is not available.
- Delay Start is not available.

How to sauté

Prep

Cut, chop, season or marinate your ingredients according to your recipe.

Preheat

1. Place the inner cooking pot into the cooker base.
2. Choose **Sauté** on the Control Panel. The 'Custom' smart program displays.
3. The default cooking temperature **High** flashes. To select it, press the **Control Dial**. Or to change it, turn the **Control Dial** to select **Low** or **Custom**, then press the dial to select it.
4. The default cooking time flashes. To select it, press the **Control Dial**. Or to change it, turn the **Control Dial** to change it.
5. Press **Start**. The display shows **On** and the Instant Pot Pro starts heating.

Cook

1. When display shows **Hot**, add ingredients.

Do not use the lid while sautéing.

2. When timer ends, display shows **End**.

You can press Cancel to stop cooking at any time.

Sautéing before Pressure or Slow Cooking

Quite often, you'll want to sauté foods to brown them before further cooking them.

1. Sauté ingredients

2. Press **Cancel**

*You can deglaze the inner cooking pot now before switching to **Pressure Cook** or **Slow Cook** (see **Deglazing**)*

3. Select the Smart Program you want to use to cook.

Deglazing

Deglazing is the process of adding a liquid to a hot pan, releasing all of the delicious, caramelized pieces stuck to the bottom.

1. Remove food from inner pot
2. Add water, broth, or wine
3. Use wooden spoon or silicone spatula to loosen food stuck to bottom of the inner cooking pot

SLOW COOK

Slow Cook lets you make your favorite simmering and stewing recipes. This program does not use pressure to cook food. Make sure steam release is set to **Vent** or use a glass lid with a venting hole.

Choose from these settings in the Slow Cook Smart Program:

Program	Temperature	Default Cook Time	Min Cook Time	Max Cook Time
Custom	High	4 hours (04:00)	30 minutes (00:30)	99 hours, 30 minutes (99:30)
Chicken	High	4 hours (04:00)	30 minutes (00:30)	99 hours, 30 minutes (99:30)
Beef	High	6 hours (06:00)	30 minutes (00:30)	99 hours, 30 minutes (99:30)
Soup	High	6 hours (06:00)	30 minutes (00:30)	99 hours, 30 minutes (99:30)
Beans	High	8 hours (08:00)	30 minutes (00:30)	99 hours, 30 minutes (99:30)

How to slow cook

Prep

Cut, chop, season or marinate your ingredients according to your recipe.

Cook

1. Place the inner cooking pot into the cooker base and add ingredients.
2. Place the lid on top of the cooker base and lock the lid.
3. Choose **Slow Cook** on the Control Panel. The 'Custom' smart program flashes. To select it, press the **Control Dial**.

4. The default cooking temperature flashes. To select it, press the **Control Dial**. Or to change it, turn the **Control Dial** until the one you want flashes, then press the dial to select it.
5. The default cooking time flashes. To select it, press the **Control Dial**. Or to change it, turn the **Control Dial** to change it.
6. Press **Start**. The Progress Bar shows **Preheating** and the Instant Pot Pro starts heating.

Note: Preheating can take some time as it slowly reaches the maximum cooking temperature.

7. When it's ready, the Progress Bar shows **Cooking** and the timer continues counting down.
8. Keep Warm setting is **On** by default. Press **Keep Warm** at any time to turn it off.

Keep Warm

When cooking completes, the display shows **End** if **Keep Warm** is turned off. If not, the timer begins counting from **00:00** up to 10 hours (**10:00**).

SOUS VIDE

Sous Vide cooks food underwater in an air-tight, food-safe bag, for a long period of time. Food cooks in its own juices and comes out delicious and very tender. This program does not use pressure to cook food. Make sure steam release is set to Vent or use a glass lid with a venting hole.

Choose from these Smart Programs:

Program	Temperature	Default Cook Time	Min Cook Time	Max Cook Time
Custom	60°C 140°F	3 hours (03:00)	30 minutes (00:30)	99 hours, 30 minutes (99:30)
Chicken	60°C 140°F	2 hours (02:00)	1 hour (01:00)	99 hours, 30 minutes (99:30)
Beef	54°C 130°F	2 hours (02:00)	1 hour (01:00)	99 hours, 30 minutes (99:30)
Egg	70°C 145°F	30 minutes (00:30)	10 minutes (00:10)	24 hours (24:00)

Other settings

- Automatic Keep Warm is set to OFF by default.
- Delay Start is not available.

What you need to sous vide

- Tongs
- Food safe, airtight, re-sealable food pouches
OR
- Vacuum sealer and food-safe vacuum bags

How to sous vide

Prep

1. Cut, chop, season or marinate your ingredients according to your recipe.
2. Add the ingredients to the cooking bag or pouch and seal tightly.

Preheat

1. Place the inner cooking pot into the cooker base.
2. Add water to the inner cooking pot.
3. Place the lid on top of the cooker base and lock the lid.
4. Choose **Sous Vide** on the Control Panel.
5. Turn the **Control Dial** to highlight the Smart Program you want to use, then press the **Control Dial** to select it.
6. The default cooking temperature flashes. To select it, press the **Control Dial**. Or to change it, turn the **Control Dial** to change it, then press the dial to select it.
7. The default cooking time flashes. To select it, press the **Control Dial**. Or to change it, turn the **Control Dial** to change it.
8. Press **Start**. The Progress Bar shows **Preheating** (the display shows **On**) and the unit starts heating.

Cook

1. When the Progress Bar shows **Hot**, set the steam release switch to Vent to release any pressure that may have accumulated while preheating.
2. Remove the lid and add the cooking bag or pouch to the inner cooking pot. Replace the lid.
3. The cooking time starts counting down.
4. When the cooking time reaches 00:00, cooking stops. You can press Cancel to stop cooking at any time.

Remove food

When cooking completes, the display shows **End**. Set the steam release switch to Vent to release any pressure that has built up, so the lid will open easily. Remove the lid and use the tongs to carefully remove the cooking pouch.

YOGURT

You can use your Instant Pot Pro to easily make delicious, fermented dairy and non-dairy yogurt.

Choose from these settings in the Yogurt Smart Program:

Program	Temperature	Default Cook Time	Min Cook Time	Max Cook Time
Custom (ferment)	Low	8 hours (03:00)	30 minutes (00:30)	99 hours, 30 minutes (99:30)
Custom (pasteurize)	High	N/A	30 minutes (00:30)	1 hours (01:00)
Custom	Custom	8 hours (03:00)	30 minutes (00:30)	99 hours, 30 minutes (99:30)

**You can adjust time from 30 minutes to 99 hours 30 minutes.*

Other settings

- Automatic Keep Warm is not available.
- Delay Start is not available.

What you need to make yogurt

- Food thermometer

How to make yogurt

Pasteurizing Milk

1. Add unpasteurized milk to the inner pot and insert inner cooking pot into the cooker base.
2. Place the lid on top of the cooker base and lock the lid.

3. Choose **Yogurt** on the Control Panel. The 'Custom' smart program flashes. To select it, press the **Control Dial**. Or to change it, turn the **Control Dial** until the one you want flashes, then press the dial to select it.
4. The 'Low' default cooking temperature flashes. The **Control Dial** to change it to **High**, then press the dial to select it.
5. Press **Start**. The Progress Bar shows **Preheating** and the Instant Pot Pro starts heating. The display shows **Boil**.
6. When it's done, the Progress Bar shows **End**.

Milk must reach a minimum of 161°F / 72°C for pasteurization to occur

Adding Culture/Starter

1. Allow pasteurized milk to cool to 43°C / 110°F; use the food thermometer to check.
2. Add a starter culture to the milk according to package instructions.
If using plain yogurt as a starter, ensure that it contains an active culture. Mix in 2 tbsp (30 mL) of yogurt per 1 gallon (3.7 L) of milk or follow a trusted recipe.
3. Place the lid back on top of the cooker base and lock it.

Ferment

1. Choose **Yogurt** on the Control Panel. The 'Custom' smart program flashes.
2. Turn the **Control Dial** to choose either **Low** or **Custom** temperature, then press the dial to select it.
3. If you select Custom, turn the **Control Dial** to select a temperature and press the dial to select it.
4. The default cooking time flashes. To select it, press the **Control Dial**. Or to change it, turn the **Control Dial** to change it.
5. Press **Start**. The Progress Bar shows **Preheating** and the Instant Pot Pro starts heating.

- When fermentation completes, the cooker beeps and display shows **End**.

A longer fermentation period will produce tangier yogurt.

- Allow yogurt to cool.
- Place in fridge for 12-24 hours to develop flavors.

How much to make?

Instant Pot Size	Minimum Milk Volume	Maximum Milk Volume
3 Quarts / 2.8 Liters	2 Cups (16 oz / 500 mL)	2 Quarts (64 oz / 1.9 L)
6 Quarts / 5.7 Liters	4 Cups (32 oz / 1000 mL)	4 Quarts (128 oz / 3.8 L)
8 Quarts / 7.6 Liters	6 Cups (48 oz / 1500 mL)	6 Quarts (192 oz / 5.7 L)

BAKE

You can use Bake to proof dough and bake foods like breads, cakes and pastries.

Choose from these settings in the Bake Smart Program:

Program	Pressure	Temperature	Default Cook Time	Max Cook Time
Custom	High Low None*	Low	30 minutes (00:30)	4 hours (04:00)
Cheesecake	High Low	High	45 minutes (00:45)	1 hours (01:00)
Bread	High Low	Custom	40 minutes (00:40)	1 hours (01:00)

**If the Custom Smart Program is set to None (no pressure) the temperature settings can be adjusted*

Other settings

- Automatic Keep Warm is set to OFF by default.
- Delay Start is available.

How to bake

Prep

1. Prepare your ingredients according to your recipe.
2. Place the ingredients into an oven-safe baking dish that fits in the Pro cooker base.

Leave approximately 1"/ 2.5 cm of space around all sides of the baking dish to allow heat to circulate evenly.

Cook

1. Place the inner cooking pot into the cooker base.
2. Add 2 cups of water to the inner cooking pot.
3. Place the steam rack inside the inner cooking pot and then place the baking dish on top of the steam rack.
4. Place the lid on top of the cooker base and lock the lid.
5. Choose **Bake** on the Control Panel. The 'Custom' smart program flashes. To select it, press the **Control Dial**. Or to change it, turn the **Control Dial** to select **Cheesecake** or **Bread**, then press the dial to select it.
6. If you chose the 'Custom' smart program the pressure setting flashes. Turn the **Control Dial** to choose **None**, **Low** or **High**, then press the dial to select it.
7. If you chose the 'Custom' smart program and 'None' for the pressure setting, the default cooking temperature flashes. To select it, press the **Control Dial**. Or to change it, turn the **Control Dial** to select a temperature, then press the dial to select it.
8. The default cooking time flashes. To select it, press the **Control Dial**. Or to change it, turn the **Control Dial** to change it.
9. The vent reminder flashes. To keep it on, press the **Control Dial**. Or to change it, turn the **Control Dial** to turn it off, then press the dial to select it.
10. Press **Start**. The Progress Bar shows **Preheating** and the Instant Pot Pro starts heating.
11. When it's ready, the Progress Bar shows **Cooking** and the timer starts counting down.
12. Keep Warm setting is **Off** by default. Press **Keep Warm** at any time to turn it on.
13. When cooking completes, the display shows **End**. If **Keep Warm** is turned on, the timer begins counting from **00:00** up to 10 hours (**10:00**).

KEEP WARM

The Keep Warm setting turns on automatically after cooking on the Pressure Cook, Rice/Grain and Slow Cook smart programs. You can also use Keep Warm to reheat food.

Choose from these settings in the Keep Warm Smart Program:

Program	Temperature Range	Min Cook Time	Max Cook Time
Custom	Low High Custom	30 minutes (00:30)	10 hours (10:00)

How to keep warm after cooking

1. When cooking is finished, automatic warming begins. The timer shows the time passed, up to 10 hours.
2. To turn automatic warming off (either during cooking or during automatic warming), press **Keep Warm** and the light above the button turns off.

How to reheat

Prep

Place the food to be reheated into the inner cooking pot or into an oven-safe baking dish that fits in the Pro cooker base. When using an oven-safe baking dish to reheat food, always add enough water into the inner cooking pot to surround the baking dish.

Reheat

1. Place the inner cooking pot into the cooker base.
2. Place the lid on top of the cooker base and lock the lid.
3. Choose **Keep Warm** on the Control Panel.
4. The 'High' default cooking temperature flashes. To select it, press the **Control Dial**. Or to change it, turn the **Control Dial** to select **Low** or **Custom**, then press the dial to select it.

5. If you chose the 'Custom' smart program the cooking temperature setting flashes. Turn the **Control Dial** to select a reheating temperature, then press the dial to select it.
6. The default cooking time flashes. Turn the **Control Dial** to select a reheating time, in 30-minute increments.
7. Press **Start**. The Progress Bar shows **Keep Warm** and the timer starts counting down.
8. When reheating completes, the display shows **End**.

FAVORITES

You can set and save 5 custom programs as Favorites for one-touch access to recipes.

Saving recipes as Favorites

1. Select any Smart program and set it up according to your recipe.
2. When you're happy with the settings, touch and hold any Fav key for 3 seconds to save the program.

Your customized program is ready to use any time you want.

You can replace a saved Favorite with a new recipe by repeating these steps again.

Using Favorite recipes

Depending on your recipe, you can add your ingredients to the inner pot before or after Pre-heating.

1. Touch the **Fav key** you want to use.
2. Touch **Start** to begin.

The display shows **On** and the progress bar shows **Pre-heating**.

*If you press a Fav key that hasn't been saved as a Favorite, the display flashes **Not Set 3** times and returns to the previous screen.*

CLEANING

Clean your Instant Pot Pro after each use. Always unplug the unit and let all parts cool to room temperature before cleaning. Before use or storing, make sure all surfaces are dry.

Part	Cleaning instructions
Accessories <ul style="list-style-type: none">• Steam Rack• Condensation Collector	<ul style="list-style-type: none">• Wash after each use• Hand wash with hot water and mild dish soap or wash in dishwasher, top rack• Never use harsh chemical detergents, powders or scouring pads on accessories• Empty and rinse condensation collector after each use
Lid and Parts <ul style="list-style-type: none">• Anti-Block Shield• Sealing Ring• Steam Release Valve• Float Valve• Silicone Cap	<ul style="list-style-type: none">• Hand wash with hot water and mild dish soap or wash in dishwasher, top rack• Remove all small parts from lid before washing• With steam release valve and anti-block shield removed, clean interior of steam release pipe to prevent clogging• To drain water from the lid after dishwashing, grasp the lid handle and hold the lid vertically over a sink, then turn it all the way around• After cleaning, store the lid upside down on the cooker base• Store sealing rings in a well-ventilated area to disperse odor• To eliminate odors from sealing ring, add 1 cup (8 oz / 250 mL) water and 1 cup (8 oz / 250 mL) white vinegar to inner cooking pot, and run Pressure Cook for 5-10 minutes, then use Quick Steam Release
Inner Cooking Pot	<ul style="list-style-type: none">• Wash after each use• Hand wash with hot water and mild dish soap or wash in dishwasher*• Hard water stains may need a vinegar-dampened sponge and scrubbing to remove• For tough or burned food residue, soak in hot water for a few hours before cleaning• Dry all exterior surfaces before placing in cooker base
Power cord	<ul style="list-style-type: none">• Use a barely-damp cloth to wipe any particles off cord
Cooker base	<ul style="list-style-type: none">• Wipe the inside of the cooker base as well as the condensation rim with a barely-damp cloth, and allow to air dry• Clean the outside of the cooker base and the control panel with a soft, barely-damp cloth or sponge

**Some discoloration may occur after machine washing, but this will not affect the cooker's safety or performance.*

TROUBLESHOOTING

Problem	Cause	Solution
Difficulty closing lid	Sealing ring not properly installed	Reposition sealing ring, ensure it is snug behind sealing ring rack.
	Contents in cooker are still hot	Gently press the float valve downward with a long utensil.
		Set Steam Release switch to Vent, then lower lid onto cooker base.
Difficulty opening lid	Pressure inside the cooker	Release pressure according to recipe; only open lid after float valve has dropped down.
	Float valve is stuck in the popped-up position due to food debris or residue	Contact customer service.
Inner pot is stuck to lid when cooking is complete	Cooling of inner pot may create suction, causing inner pot to adhere to the lid	To release the vacuum, set Steam Release to Vent.
Steam leaks from side of lid	No sealing ring in lid	Install sealing ring.
	Sealing ring damaged or not properly installed	Replace sealing ring.
	Food debris attached to sealing ring	Remove sealing ring and clean thoroughly.
	Lid not closed properly	Open, then close lid.
	Sealing ring rack is warped or off-center	Remove sealing ring from lid, check sealing ring rack for bends or warps. Contact Consumer Care.
	Inner cooking pot rim may be misshapen	Replace inner pot.
Minor steam leaking/hissing from steam release vent during cooking cycle	Cooker is regulating excess pressure	This is normal; no action required.

Problem	Cause	Solution
Steam gushes from steam release vent when Steam Release switch is in Seal position	Not enough liquid in the inner pot	Add thin, water-based liquid to the inner pot according to its size: 6 Quart: 1 1/2 cups (12 oz / 375 mL) 8 Quart: 2 cups (16 oz / 500 mL)
	Pressure sensor control failure	Contact Consumer Care.
	Internal steam release valve not seated properly	Check Steam Release switch to ensure it's set to Seal.
Display remains blank after connecting the power cord	Bad power connection or no power	Inspect power cord for damage. If damage is noticed, contact Consumer Care. Check outlet to ensure it is powered.
	Cooker's electrical fuse has blown	Contact Consumer Care.
Occasional clicking or light cracking sound	The sound of power switching and expanding pressure board when changing temperatures	This is normal; no action needed.
	Bottom of the inner pot is wet	Wipe exterior surfaces of inner pot. Ensure heating element is dry before inserting inner pot into cooker base.
Error code appears on display and cooker beeps continuously	There is an issue with the cooker	Read "Error Codes" for instructions.





ERROR CODES

If the control panel displays an error code from this list, there is an issue with the Instant Pot Pro. Here are the actions you should take to fix the problem.

Problem	Cause	Solution
C1 C2 C6 C6H C6L	Faulty sensor	Contact Consumer Care.
C5	Temperature is too high because inner pot is not placed in the cooker base	Press Cancel and wait for heating element to cool; ensure there are no foreign objects in cooker base; insert or reposition inner pot in cooker base and re-enter commands.
	Temperature is too high because there is no water in inner pot	Check for scorching on bottom of inner pot. Add thin, water-based liquid to the inner pot according to its size: 3 Quart: 1 cup (8 oz / 250 mL) 6 Quart: 1 1/2 cups (12 oz / 375 mL) 8 Quart: 2 cups (16 oz / 500 mL)
C7 or NoPr	Heat element has failed	Contact Consumer Care.
	Not enough liquid	Add thin, water-based liquid to the inner pot according to its size: 3 Quart: 1 cup (8 oz / 250 mL) 6 Quart: 1 1/2 cups (12 oz / 375 mL) 8 Quart: 2 cups (16 oz / 500 mL)
	Quick release button is in the Vent position	Check Steam Release switch to ensure it's set to Seal.
Lid	Lid is not in the correct position for the selected program	Open and close the lid. Do not use a lid when using Sauté.
Food burn	High temperature detected at bottom of inner pot; cooker automatically reduces temperature to avoid overheating	Starch deposits at the bottom of the inner pot may have blocked heat dissipation. Turn the cooker off, release pressure according to the recipe, and inspect the bottom of the inner pot.
PrSE	Pressure has accumulated during a non-pressure cooking program	Set Steam Release switch to Vent.

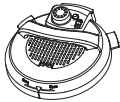
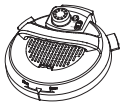
REPLACEMENT PARTS

We offer genuine replacement parts for your Instant Pot Pro Multi-Cooker, if you need them. Visit www.instanthome.com to order.

	Part	Part number
	Lid Evo Plus Pro 8QT	312-0028-01
	Lid Evo Plus Pro 6QT	310-0026-01
	SS Inner Pot w Handles Evo Series 6QT	212-0403-01
	SS Inner Pot w Handles Evo Series 8QT	212-0603-01
	Float Valve Evo Plus Pro 6QT Red	310-0119-01
	Float Valve Evo Plus Pro 8QT Red	310-0120-01
	Steam Release Diffuser Evo Plus Pro	310-0121-01
	6QT Evo Plus Steam Release Pack*	310-0030-01
	8QT Evo Plus Steam Release Pack*	310-0031-01
	User Manual	399-1268-03US

* The Evo Plus Steam Release Packs (that are compatible with the Pro Series) DO NOT include the Steam Release Valve. It does include the Float Valve, Silicone Cap, Steam Release Cover and release post, but not the Steam Release Valve.

LEARN MORE

There's a whole world of Instant cooking information and help just waiting for you. Here are some of the most helpful resources.

Register your product

[Instanhome.com/register](https://instanhome.com/register)

Contact Consumer Care

In the Instant Brands Connect™ app
[Instanhome.com/customer-care-center](https://instanhome.com/customer-care-center)
support@instanhome.com

Download the Instant Brands Connect™ app

Discover guided cooking and recipes
Available at iOS and Android app stores

Cooking charts and more recipes

[Instanhome.com](https://instanhome.com)

How-to videos, tips and more

[Instanhome.com](https://instanhome.com)

Replacement parts and accessories

[Instanhome.com](https://instanhome.com)

Join the community



Product specifications

Model	Volume	Wattage	Power
Pro 60	6 Quarts 5.7 Litres	1200 W	120V/60Hz
Pro 80	8 Quarts 7.6 Litres	1400 W	120V/60Hz

WARRANTY

One (1) Year Limited Warranty

This One (1) Year Limited Warranty applies to purchases made from authorized retailers of Instant Brands LLC ("Instant Brands") by the original appliance owner and is not transferable. Proof of original purchase date and, if requested by Instant Brands, return of your appliance, is required to obtain service under this Limited Warranty. Provided the appliance was used in accordance with the use & care instructions, Instant Brands will, in its sole and exclusive discretion, either: (i) repair defects in materials or workmanship; or (ii) replace the appliance. In the event that your appliance is replaced, the Limited Warranty on the replacement appliance will expire twelve (12) months from the date of receipt. Failure to register your product will not reduce your warranty rights. The liability of Instant Brands, if any, for any allegedly defective appliance or part will not exceed the purchase price of a comparable replacement appliance.

What is not covered by this warranty?

- Products purchased, used, or operated outside of the United States and Canada.
- Products that have been modified or attempted to be modified.
- Damage resulting from accident, alteration, misuse, abuse, neglect, unreasonable use, use contrary to the operating instructions, normal wear and tear, commercial use, improper assembly, disassembly, failure to provide reasonable and necessary maintenance, fire, flood, acts of God, or repair by anyone unless directed by an Instant Brands representative.
- Use of unauthorized parts and accessories.
- Incidental and consequential damages.
- The cost of repair or replacement under these excluded circumstances.

EXCEPT AS EXPRESSLY PROVIDED HEREIN AND TO THE EXTENT PERMITTED BY APPLICABLE LAW, INSTANT BRANDS MAKES NO WARRANTIES, CONDITIONS OR REPRESENTATIONS, EXPRESS OR IMPLIED, BY STATUTE, USAGE, CUSTOM OF TRADE OR OTHERWISE WITH RESPECT TO THE APPLIANCES OR PARTS COVERED BY THIS WARRANTY, INCLUDING BUT NOT LIMITED TO, WARRANTIES, CONDITIONS, OR REPRESENTATIONS OF WORKMANSHIP, MERCHANTABILITY, MERCHANTABLE QUALITY, FITNESS FOR A PARTICULAR PURPOSE OR DURABILITY.

Some states or provinces do not allow for: (1) the exclusion of implied warranties of merchantability or fitness; (2) limitations on how long an implied warranty lasts; and/or (3) the exclusion or limitation of incidental or consequential damages; so these limitations may not apply to you. In these states and provinces, you have only the implied warranties that are expressly required to be provided in accordance with applicable law. The limitations of warranties, liability, and remedies apply to the maximum extent permitted by law. This limited warranty gives you specific legal rights, and you may also have other rights which vary from state to state or province to province.

Product Registration

Please visit www.instanthome.com/register to register your new Instant Brands appliance. Failure to register your product will not diminish your warranty rights. You will be asked to provide the store name, date of purchase, model number (found on the back of your appliance) and serial number (found on the bottom of your appliance) along with your name and email address. The registration will enable us to keep you up to date with product developments and recipes, and contact you in the unlikely event of a product safety notification. By registering, you acknowledge that you have read and understand the instructions for use, and warnings set forth in the accompanying instructions.

Warranty Service

To obtain warranty service, please contact our Consumer Care Department by email to support@instanthome.com. You can also create a support ticket online at www.instanthome.com. If we are unable to resolve the problem, you may be asked to send your appliance to the Service Department for quality inspection. Instant Brands is not responsible for shipping costs related to warranty service. When returning your appliance, please include your name, mailing address, email address, phone number, and proof of the original purchase date as well as a description of the problem you are encountering with the appliance.

In Canada, distributed by
Instant Brands Inc.
400-1565 Carling Avenue
Ottawa, ON K1Z 8R1

In U.S., distributed by
Instant Brands LLC
3025 Highland Parkway, Suite 700
Downers Grove, IL 60515 U.S.

instanthome.com

© 2023 Instant Brands
112-0123-01 / 113-0044-01

Art release date
11/15/2023

INSTANT, INSTANT POT
and INSTANT BRANDS
are registered trademarks
of Instant Brands