



Before you start, scan
for assembly, operation,
care and recipes!
GREENPAN.US/FROST

FROST ICE CREAM & FROZEN DRINK MAKER

USER GUIDE & RECIPES

IMPORTANT SAFEGUARDS

When using an electrical appliance, basic safety precautions should always be followed to reduce the risk of fire, electric shock, and or injury, including the following:

1. **Read all instructions before using.**
2. If the supply cord is damaged, it must be replaced by the manufacturer or its service agent or a similarly qualified person in order to avoid a hazard.
3. This appliance is not intended for use by persons (including children) with reduced physical, sensory or mental capabilities, or lack of experience and knowledge, unless they have been given supervision or instruction concerning use of the appliance by a person responsible for their safety. Children should be supervised to ensure that they do not play with the appliance.
4. This appliance can be used by children aged from 8 years and above and persons with reduced physical, sensory or mental capabilities or lack of experience and knowledge if they have been given supervision or instruction concerning use of the appliance in a safe way and understand the hazards involved. Children shall not play with the appliance. Cleaning and user maintenance shall not be made by children without supervision.
5. Turn the appliance OFF, then unplug the appliance from the outlet when not in use, before assembling or disassembling parts, and before cleaning. To unplug, grasp the plug by the body and pull from the outlet. NEVER unplug by grasping and pulling the flexible cord.
6. ALWAYS use the appliance on a dry and level surface.
7. Keep hands, hair, and clothing out of the mixing container when loading and operating.
8. During operation and handling of the appliance, avoid contact with moving parts.

9. Before operation, ensure all utensils are removed from containers. Failure to remove utensils can cause containers to shatter and potentially result in personal injury and property damage.
10. DO NOT carry the unit by the handle ONLY lift when grasping both sides of the bottom of the unit.

WARNING:

- Do not store explosive substances such as aerosol cans with a flammable propellant in this appliance.
- Keep ventilation openings, in the appliance enclosure or in the built-in structure, clear of obstruction.
- Do not use mechanical devices or other means to accelerate the defrosting process, other than those recommended by the manufacturer.
- Do not damage the refrigerant circuit.
- Do not use electrical appliances inside the food storage compartments of the appliance, unless they are of the type recommended by the manufacturer.
- When positioning the appliance, ensure the supply cord is not trapped or damaged.
- Do not locate multiple portable socket-outlets or portable power supplies at the rear of the appliance.
- When disposing of the appliance, do so only at an authorized waste disposal center. Do not expose to flame.

DANGER:

- Risk of fire or explosion. Flammable refrigerant used. Do not use mechanical devices to defrost refrigerator. Do not puncture refrigerant tubing.
- Risk of fire or explosion. Flammable refrigerant used. To be repaired only by trained service personnel. Use only manufacturer-authorized service parts. Any repair equipment used must be designed for flammable refrigerants. Follow all manufacturer repair instructions. Do not puncture refrigerant tubing.

CAUTION:

- Risk of fire or explosion. Dispose of refrigerator properly in accordance with the applicable federal or local regulations. Flammable refrigerant used.
- Risk of fire or explosion due to puncture of refrigerant tubing; follow handling instructions carefully. Flammable refrigerant used.



The refrigerant (R290) is flammable.

- Risk of fire/Flammable materials.

The refrigerant propane (R290) is contained within the refrigerant circuit of the appliance, a natural gas with a high level of environmental compatibility, which is nevertheless flammable. During transportation and installation of the appliance, ensure that none of the components of the refrigerant circuit becomes damaged. Refrigerant is flammable gas, do not expose to open flame. When disposing of this equipment, be sure to dispose of it at an authorized waste disposal center.

If the refrigerant circuit should be damaged:

- Avoid opening flames and sources of ignition.
 - Thoroughly ventilate the room in which the appliance is situated.
1. Do not use outdoors.
 2. This appliance is intended to be used in household and similar applications such as:
 - Staff kitchen areas in shops, offices and other working environments;
 - Farm houses and by clients in hotels, motels and other residential type environments;
 - Bed and breakfast type environments.
 - Catering and similar non retail applications.
 1. Before using the appliance for the first time, please wait 2 hours after positioning it, and keep the transparent lid open for at least 2 hours.
 2. Ensure the voltage is compliant with the voltage range stated on the rating label, and ensure the earthing of the socket is in good condition.
 3. Do not upend this product or incline it over a 45° angle.

4. To protect against risk of electric shock, do not pour water on cord, plug and ventilation, immerse the appliance in water or any other liquid.
5. The plug must be removed before cleaning, maintaining or filling the appliance.
6. Keep the appliance 20cm from other objects to ensure the good heat releasing.
7. Do not use the accessories which are not recommended by Manufacturer.
8. Do not use the appliance close by flames, hot plates or stoves.
9. Do not switch on the power button frequently (ensure 5 min. interval at least) to avoid the damage of compressor.
10. Do not use outdoors.
11. Never clean with scouring powders or hard implements.
12. Please keep the instruction manual.
13. Do not put your fingers into the outlet to avoid danger.
14. If the SUPPLY CORD is damaged, it must be replaced by the manufacturer, its service agent or similarly qualified persons in order to avoid a hazard.
15. If there is a fault, please check it again before requesting maintenance. If the fault still cannot be eliminated, please go to the designated maintenance point for maintenance, or contact our company, and please confirm the following items.

SAVE THESE INSTRUCTIONS FOR HOUSEHOLD USE ONLY

SPECIAL CORD SET INSTRUCTIONS:

A short power-supply cord is provided to reduce the risks resulting from becoming entangled in or tripping over a longer cord. Longer extension cords may be used if care is exercised. If a long extension cord is used, the marked electrical rating of the extension cord should be at least as great as the electrical rating of the appliance, and the longer cord should be arranged so that it will not drape over the countertop or tabletop where it can be pulled on by children or animals or tripped over.

NO FREEZER, NO WAITING, NO HASSLE.

Welcome to the GreenPan Frost Ice Cream and Frozen Drink Maker, the easiest way to bring frozen treats home! We have helpful tips, tricks, and quick recipes to help you get started creating your favorite slushie or frozen cocktail, homemade ice cream, or creamy milkshakes. **Enjoy!**



CONTENTS

Getting Started

- 06 Before First Use & Parts
- 07 Accessories Guide
- 08 Controls
- 09 Assembly
- 11 Operation
- 13 Cleaning & Maintenance
- 14 Alcohol Requirements
- 15 Sugar Requirements
- 16 Helpful Tips

Recipes

- 18 Prep-Free Drinks
- 19 Frozen Cocktail Guidelines

Soft Serve Ice Creams

- 20 Vanilla Ice Cream
- 21 Peppermint Ice Cream

Sorbet

- 22 Apple Ginger Sorbet
- 23 Orange Sorbet

Milkshakes

- 24 Chocolate Milkshake
- 25 Coffee Milkshake

Frozen Custard

- 26 Classic Frozen Custard
- 27 Caramel Frozen Custard

Frozen Yogurt

- 28 Vanilla Frozen Yogurt
- 29 Honey Frozen Yogurt
- 30 Rose & Cardamom Frozen Yogurt

Slushie

- 31 Cranberry Orange Slushie
- 32 Lemonade Iced Tea Slushie
- 33 Soda Slushie

Frozen Cocktails

- 34 Frozen Mojito
- 35 Frozen Rosé
- 36 Frozen Whiskey Sour

Frozen Mocktails

- 37 Frozen Paloma Mocktail
- 38 Frozen Piña Colada Mocktail

Troubleshooting & Warranty

- 39 Troubleshooting
- 40 Dishwasher Safe Guide
- 41 Warranty

Before You Start:

Scan this code for assembly, operation, care and recipes!
greenpan.us/frost



BEFORE FIRST USE & PARTS

1. Read all instructions and important safeguards.
2. Remove all packaging materials and check that all items have been received in good condition.
3. Tear up all plastic bags and dispose of properly as they can pose a suffocation or choking risk to children.

4. Wash all accessories in warm, soapy water. Rinse and dry thoroughly.
5. Ensure the main body is level on a flat, solid and dry surface.

NOTE: Do not use harsh abrasive cleaners. If washing accessories in the dishwasher, a slight discoloration to accessories may occur. This is cosmetic only and will not affect performance.

WHAT'S INSIDE

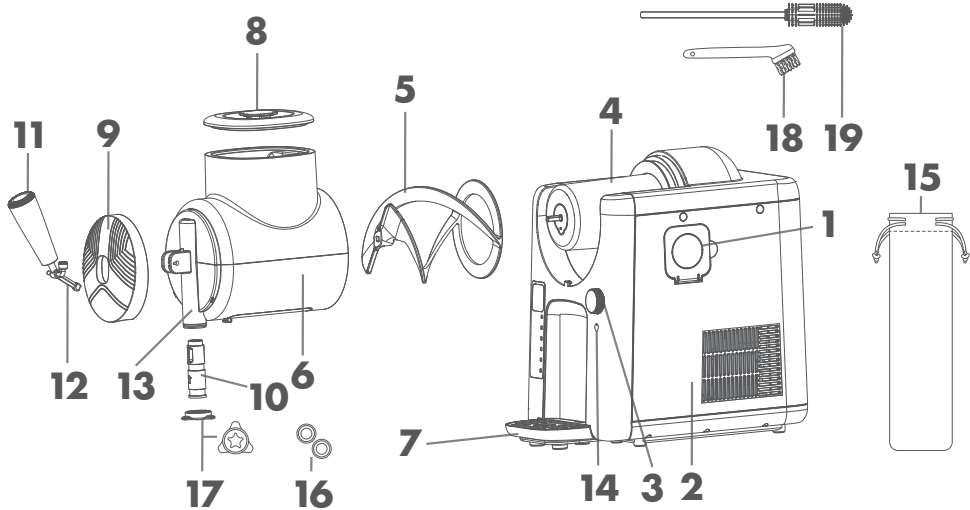

- | | | |
|---------------------------------|-------------------------------|--|
| 1. Ice Cream Cone Holder | 8. Mixing Bowl Cover | 15. Accessory Bag |
| 2. Main Body | 9. Removable Decorative Cover | 16. Extrusion Head Gaskets (x2) |
| 3. Control Dial | 10. Extrusion Head | 17. Swirl Extrude Cover Accessory (x2) |
| 4. Cooling Rod | 11. Handle | 18. Bristle Cleaning Brush |
| 5. Stirring Blade | 12. Handle Fixing Pin | 19. Silicone Cleaning Brush/Installation Rod |
| 6. Mixing Bowl | 13. Extrusion Head Slot | |
| 7. Two-Part Removable Drip Tray | 14. Mode Button | |

GUIDE TO INCLUDED ACCESSORIES

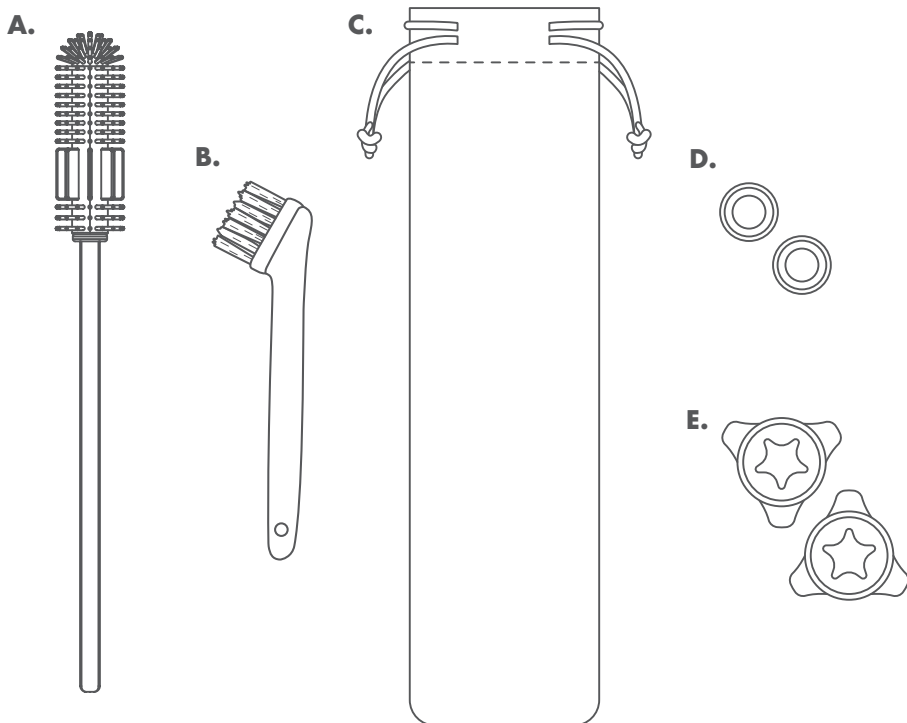

PIECES

A. Silicone Cleaning Brush/Installation Rod
Used to clean the extrusion head slot. The handle can be used to push the extruder head in and out of the extrusion head slot.

B. Bristle Cleaning Brush
Used to clean mixing bowl and attachments.

C. Accessory Bag

D. Extrusion Head Gaskets (x2)
These 2 extra replacement gaskets for the extrusion head are included if they are ever lost or damaged.

NOTE: damaged gaskets can cause minor leaks from the extrusion head.)

E. Swirl Extrude Cover Accessories (x2)
These extruder cover accessories are included to add a classic swirl pattern to your ice cream, sorbet, frozen custards, frozen yogurts and more. An additional piece is included if one is ever lost or damaged.

CONTROLS

CONTROL PANEL

- 1. Slushie:** Use slushie mode to make icy treats and more.
- 2. Soft Ice Cream:** Use for ice cream, frozen custards, frozen yogurts, sherbet and more.
- 3. Spiked Slushies:** Use spiked slushie mode to make delicious icy drinks with alcohol.
- 4. Sorbet:** Make fresh fruit sorbets for healthier alternatives.
- 5. Milkshake:** Make soft or thick milkshakes with milkshake mode.
- 6. Extrude/Clean:** Use extrude mode to clear the mixing bowl of ingredients when ready. Once done add warm water and soap to previously extruded mixing bowl for a quick clean.

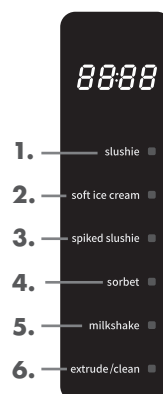

CONTROL DIAL:

Turn the control dial to cycle between textures on specified modes.

Press the control dial to start the mode.

Press and hold the control dial to stop a mode.



MODE BUTTON:

Use the mode button to cycle between the 6 modes.

Tip: Once unit is in COOL, press mode button to begin extrude mode. Press again to go back to cool mode.



Mode

ASSEMBLY INSTRUCTIONS

NOTICE: Keep unit upright for at least 2 hours before first use.

1. Ensure all parts are fully cleaned and the Ice Cream & Frozen Drink Maker is level on a flat, solid surface. (Fig. 1)
2. Insert the two-part removable drip tray in front of the motor base. Insert the drip tray from the wider side and slide under the main body. (Fig. 2)
3. Install the stirring blade on the cooling rod. By aligning the square end of the cooling rod with the opening of the stirring blade. Make sure the bottom of the stirring blade is affixed to the cooling rod. (Fig. 3)
4. Attach the removable decorative cover onto the end of the mixing bowl and turn to the right to lock in place. (Fig. 4)
5. Insert the mixing bowl onto the main body with the decorative cover facing outward. Once in the correct position turn the mixing bowl clockwise to lock into place. Please reference the icons on the main body of the unit for further reference.
6. Put the removable extrude head into the extrude head slot and install the latch sleeve to tighten it. This part must be in place to operate. The back end of the silicone cleaning brush/installation rod can be used here to insert properly. See insertion directions below.

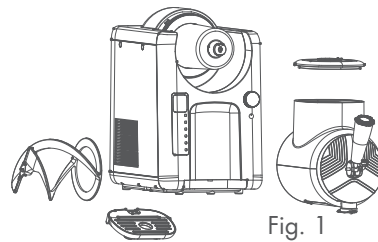

Fig. 1

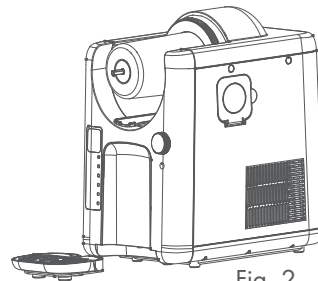

Fig. 2

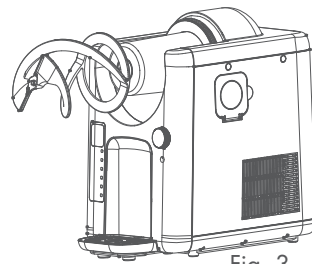

Fig. 3

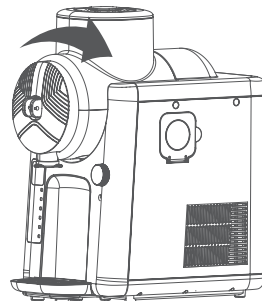

Fig. 4

Need a hand?

Scan this code for a helpful assembly video!



GETTING STARTED

REMOVABLE EXTRUDE HEAD & HANDLE INSTALLATION

1. Insert extrusion head into the extrude head slot right side up (as shown below). Use the back end of the Silicone Cleaning Brush/Installation Rod to push the extrusion head into the correct place. This will allow for the handle to be inserted. (Fig. 1)
2. Once the extrusion head is in place, insert the handle into the opening of the extrusion head slot. Make sure the handle is facing upward. (Fig. 2)
3. Hold this handle in place and thread the handle fixing pin through the hole on the mixing bowl and the hole on the handle. Make sure that the pin latch is in the correct position and place all the way through. Lock the extrusion pin in the up position to continue.
4. To disassemble for cleaning remove the pin and handle and thread the backside of the Silicone Cleaning Brush/Installation Rod through the top of the extrude head slot to slide out the removable extrude head. (Fig. 3)

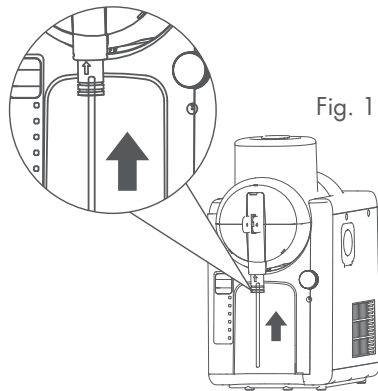

Fig. 1

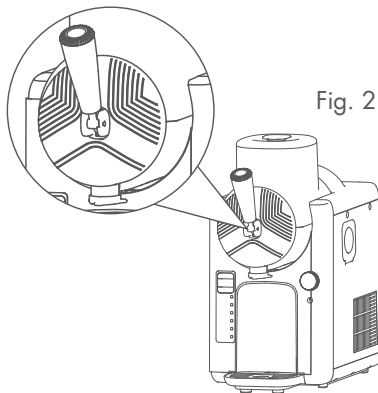

Fig. 2

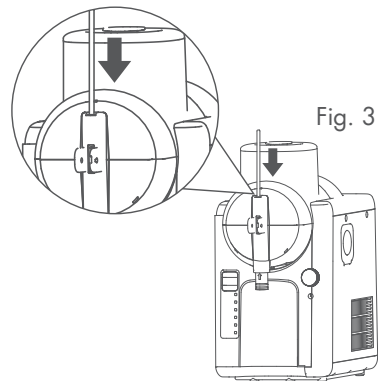

Fig. 3

OPERATION

1. Plug the Ice Cream & Frozen Drink Maker into an outlet. Once this is done the screen will illuminate. If a texture or new mode is not selected in 1 minute the unit will go into standby mode.

2. To select a mode press the Mode Button below the dial until you select your desired mode. The control panel indicator will illuminate on the current mode selected. (Fig. 1)

3. Once the correct mode is chosen use the control dial to select the desired texture of your frozen treat. Each mode has its own texture level. For reference, Level 1 is thinner and softer and higher levels are more firm or thick. Press the control dial to begin the mixing process.

4. **PLEASE NOTE:** Always make sure handle is in up position before adding Ingredients into the mixing bowl. After desired texture is selected and mixing has begun, open the mixing bowl cover and add your ingredients into the mixing bowl. (Fig. 2)

IMPORTANT: If adding very cold premixed ingredients from the refrigerator to the Frost, use texture level 3 to help prevent jamming. If you want a firmer texture after this has completed, increase the texture level after the COOL Mode has started.

5. The Ice Cream & Frozen Drink Maker will begin to make your frozen treat. Time will vary depending on the mode selected, temperature of the mix, and amount of content in the mixing bowl.

6. Once the Ice Cream & Frozen Drink Maker determines when the mixture is ready the unit will beep and COOL will display on the screen.

7. You can extrude your frozen treats while in COOL mode by pulling the handle down as the stirring blade will continue to spin. If you want to extrude more quickly, simply press the mode button and the program will change to extrude/clean. After 1 minute this will return to the cool mode, or you can press the mode button again to return to the previous mode. (Fig. 3)

8. If you notice the mixture is not to your desired texture or firmness in cool mode increase the texture level by turning the control dial to a higher setting. A texture cannot be decreased, ONLY increased once in COOL mode. After higher setting is selected press the control dial to confirm.

9. If you want to stop the cooling/mixing process at any time, hold down the control dial for 3 seconds. This will cancel the selected mode and texture selected.

Fig. 1

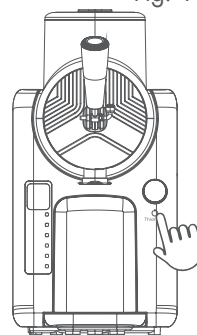

Fig. 2

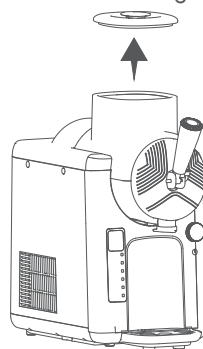
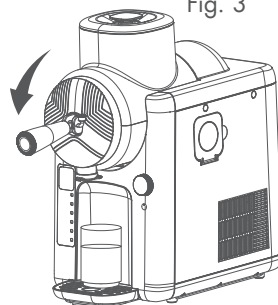

Fig. 3



EXTRUDE/CLEAN MODE

In this mode, the stirring blade rotates at a high speed, without cooling, to extrude or clean all contents from the unit.

EXTRUDE

1. Select Extrude/Clean mode by pressing the mode button. Confirm mode by pressing the control dial.
2. The stirring blade will begin to spin. Put a large bowl or storage container under the removable extrusion head. Once ready pull the handle down.

CLEAN

1. Once all of the ingredients are extruded from the mixing bowl. Put the handle into the up position, **add warm water and a small amount of soap**. Fill up to the bowl's max fill line.
 2. The stirring blades will continue to rotate to clean the mixing bowl, cooling rod and stirring blade.
 3. The Extrude/Clean mode will work for a total of 5 minutes. Let the soapy water stir for approximately one minute. Add a large bowl or pitcher under the Ice Cream & Frozen Drink Maker and pull the handle down to extrude the contents of the mixing bowl. We recommend repeating this 1 or 2 times to completely clean the unit. Please reference cleaning & maintenance instructions on page 13 for more details.
 4. Press and hold the control dial to exit this mode or let the 5 minutes elapse.
- TIP:** Adding warm water and soap more than once will clean the inner parts more.

CLEANING & MAINTENANCE

IMPORTANT: For easier cleaning of internal parts always use extrude/ clean mode before removing mixing bowl. The Extrude/Clean mode will work for a total of 5 minutes. Let the soapy water stir for approximately one minute. Add a large bowl or pitcher under the Ice Cream & Frozen Drink Maker and pull the handle down to extrude the contents of the mixing bowl. We recommend repeating this 1 or 2 times to completely clean the unit. The Stirring blade, mixing bowl, two-part removable drip tray, extrusion head, cleaning brush and removable decorative cover are top rack dishwasher safe.

DISASSEMBLY FOR CLEANING

1. Pull out the pin, remove the handle, and rotate counter clockwise to remove the decorative cover. (Fig. 1)
2. Use the back end of the silicone cleaning brush/installation rod to push out the removable extrusion head for cleaning, and then use the cleaning brush to clean the extrude head slot. (Fig. 2)
3. Rotate the mixing bowl counterclockwise, then gently remove the mixing bowl from the main unit and set it aside. (Fig. 3)
4. Remove the stirring blade from the cooling rod and wipe the remaining liquid on and around the cooling rod with a dry dishcloth. (Fig. 4)
5. Slide the two-part removable drip tray out of the main body and clean the parts with wet soapy water. Dry before using again. (Fig. 5)

All dishwasher safe parts should NOT be cleaned with a heated dry cycle.

TIP: When cleaning the mixing bowl in the dishwasher remove the bowl bottom cover before putting into the dishwasher. Once cycle is complete let the mixing bowl dry without bottom cover.

Fig. 1

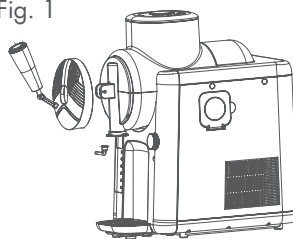

Fig. 2

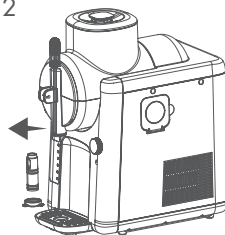

Fig. 3

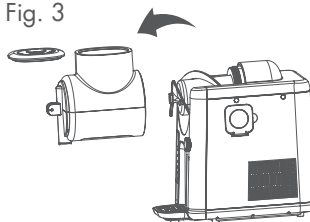

Fig. 4

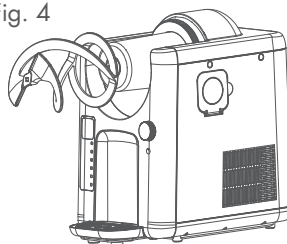
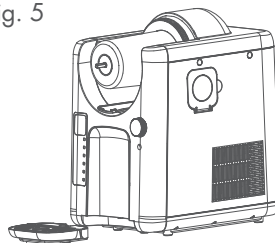

Fig. 5



ALCOHOL REQUIREMENTS

HARD ALCOHOL/SPIRIT GUIDELINES

Creating a delicious frozen cocktail is easy with your Ice Cream/Frozen Drink maker! Just follow these simple guidelines:

Option 1: Using a canned or bottled beverage (Beer, Wine, Seltzer etc.)

- Your drink must be between 2.8% and 16% alcohol for the best results.
- Lower alcohol (closer to 2.8%)? It will freeze faster and have a more icy texture.
- Higher alcohol (closer to 16%)? It will freeze more slowly and have a slushier texture.
- Too much alcohol? If it's over 16%, it won't freeze properly and will have a very thin texture.

Option 2: Mixing Hard Spirits Into Your Drink.

If adding a hard spirit (vodka, tequila, rum, etc.) to any liquids to create your own spiked slushie, follow the chart below to keep the balance right:

Total Recipe Size	Maximum Alcohol Amount
3 Cups (24 oz)	½ Cup (4 oz)
4½ Cups (36 oz)	¾ Cup (6 oz)
6 Cups (48 oz)	1 Cup (8 oz)

The chart above is a guide for hard alcohol/spirits with a 35% + alcohol content only.

When using other prep free bottled or canned alcoholic beverages such as wine, beer, seltzer, or premade cocktails, refer to the PREP FREE DRINKS section on page 18.

Important:

Adjusting Your Slushie's Texture

If your drink isn't freezing as expected:

- Too icy? Increasing the alcohol content slightly, adding more sugar or lowering the texture setting can all help.
- Too soft? Reducing the alcohol content slightly, reducing the sugar or increasing the texture setting, can all help.
- Still not right? Adjust the texture setting on your machine and tweak the alcohol/sugar balance until you get the perfect slushie.

SUGAR REQUIREMENTS

SUGAR CONTENT

The entire recipe must contain at least 4% sugar. Refer to drink/liquid nutrition label to ensure sugar content meets the recommended minimums below:

Listed Serving Size	Minimum Total Sugar Amount
8 oz (240 ml)	8 g
12 oz (355 ml)	11 g
20 oz (591 ml)	18 g

If a drink does not meet minimum requirement of total sugar: Add 1–2 tablespoons of flavored syrup, juice, sugar, date sugar, coconut sugar, maple syrup, agave, simple syrup, or honey per serving. Combine additional sugar with the base prior to pouring into unit.

If there is not enough sugar in the recipe added to the machine the display will illuminate “EEE” and the Ice Cream/Frozen Drink Maker will beep. To avoid this, always have a minimum of 4% sugar in the mixture. To clear this, you must either add more liquid or allow the mixture to thaw for 30 minutes before restarting.

PLEASE NOTE: Sugar can be added to the ingredients before EEE is displayed on screen.

IMPORTANT HELPFUL TIPS

Minimum Input: 3 cups (24 oz/710 ml)

Maximum Input: 6 cups (48 oz/1.4 L)



DO NOT add hot ingredients, ice, or solid ingredients like fruit, ice cream, chocolate chips, or frozen fruit.



The entire recipe must contain at least 4% sugar. If the sugar content is below 4%, you can add syrup or sugar.



Use the control dial to find your ideal texture.



For best and faster results, chill liquid(s) before adding to the unit.



For an extra icy drink, chill your glass before dispensing your creations.



For best results when using soda or carbonated beverages vigorously stir or shake the soda first to reduce the level of carbonation.

Tip: Whether fresh squeezed or store bought, for a better sorbet texture straining out any large pieces of pulp in the juice is key!

Note: ONLY add mix-ins after you have extruded into your own bowl or container.

DO NOT add mix-ins to the mixing bowl, it will clog and break the machine.

IMPORTANT: If adding very cold premixed ingredients from the refrigerator to the Frost, use texture level 3 to help prevent jamming. If you want a firmer texture after this has completed, increase the texture level after the COOL Mode has started.

IMPORTANT HELPFUL TIPS

PLEASE NOTE: the maximum input will expand due to freezing. Final output is up to 64oz. This will depend on the ingredients being used.

For the best dispensing experience, fill the unit to the max-fill line (48 oz)

Always be sure to have handle in the UP position when filling with ingredients. This will prevent ingredients from extruding from the extrusion head.

- Keep the Ice Cream and Frozen Drink Maker upright for at least 2 hours before first use.
- Mixture can be extruded at any time during the cooling/mixing process. It is not necessary to go into the Extrude/Clean Mode to dispense contents from this machine. As long as the stirring blade is moving contents can be dispensed.
- The Ice cream & Frozen Drink Maker will automatically go into cool mode for 2 hours after the selected texture setting has been reached. The Ice Cream & Frozen Drink Maker will automatically shut off after cool mode has finished.
- For best results, chill liquid(s) or blended ingredients before adding to the unit.
- We recommend that any Ice Cream, Frozen Yogurt or Sorbet that you do

not eat immediately be stored in a sealed container in your freezer.

- Please note that ingredients always taste sweeter before they are frozen, do not worry if it seems too sweet before adding it to the Ice Cream and Frozen Drink Maker.
- When using the Spiked Slushie mode, all pre-made mixes and recipes must contain between 2.8% and 16% alcohol.
- If some recipes are too dense the extrusion head cover accessory can block the contents from extruding particularly for denser water based recipes. We suggest removing this to solve for this issue.
- For the best dispensing experience, fill the unit to the max-fill line
- **DO NOT OVERFILL.**

IMPORTANT:

For best results when using soda or carbonated beverages vigorously stir or shake the soda first to reduce the level of carbonation.

DO NOT add frozen fruit, frozen vegetables, or ice to the unit.

DO NOT add hot ingredients into the Frost if you are intending to make frozen Treats.

DO NOT store ingredients inside the bowl when storing.

MODE REFERENCE TABLE

Preset	Default	Texture Range and Default Texture
Slushie	L:4	Levels 1-7 If you like softer slushies choose a lower level. If you are looking for more texture and ice use a higher level. For lower sugar drinks, it is recommended to choose level 1 or 2.
Soft Ice Cream	L:4	Levels 1-6 If you like softer ice cream choose a lower level. If you are looking for firmer ice cream use a higher level.
Spiked Slushie	L:4	Levels 1-7 If you like softer slushies choose a lower level. If you are looking for more texture and ice use a higher level. For lower sugar drinks, it is recommended to choose level 1 or 2.
Sorbet	L:4	Levels 1-6 If you like softer sorbet choose a lower level. If you are looking for firmer sorbet use a higher level.
Milkshake	L:3	Levels 1-4 If you like softer milkshake choose a lower level. If you are looking for thicker milkshake use a higher level.
Extrude/Clean	/	5 min

PREP-FREE DRINKS

1. Pick a Prep-Free bottled or canned beverage.

See options in below section for Slushies, Frozen cocktails and Frozen juices.

2-3 SERVINGS: Add 2 1/2 cups **4-6 SERVINGS:** Add 5 cups

2. Chill ingredients before adding.

Chilling your ingredients will result in less icy and smoother texture overall.

3. Select Spiked Slushie or Slushie Modes

Adjust the temperature for your preferred texture.

4. Serve & Enjoy

EASY SLUSHIES

- Soda (root beer, cola, ginger ale, orange, grape, cream, or other flavored soda)
- Sweetened Iced Tea
- Lemonade
- Sports Drinks
- Kombucha
- Limeade
- Fruit Punch
- Energy Drinks

FROZEN COCKTAILS

Bottled or Canned:

- Sour Beers
- Wine (white or rosé)
- Hard Lemonade
- Hard Seltzers

- Hard Kombucha
- Hard Cider
- Hard Tea
- Premixed Margaritas

Pre-made Cocktails:

- Old Fashioned
- Cosmopolitan
- Rum Punch

JUICE SLUSHIES

- Fruit Punch
- Pineapple Juice
- Orange Juice
- Apple Juice/Apple Cider
- Bottled Pre-Made Smoothies
- Cherry Juice
- Cranberry Juice
- Grape Juice
- Mango Juice
- Tropical Juice
- Watermelon Juice

NOTE: Please refer to page 14 for Sugar & Alcohol requirements.

FROZEN COCKTAIL GUIDELINES

1. PICK A MIXER. (EXAMPLES BELOW)

2-3 SERVINGS

Add 2 1/2 cups

- Mai Tai Mix
- Hurricane Mix
- Margarita Mix
- Daiquiri Mix
- Whiskey Sour Mix

4-6 SERVINGS

Add 5 cups

- Piña colada Mix
- Bloody Mary Mix
- Cosmo Mix
- Other

2. ADD ALCOHOL.

2-3 SERVINGS

Add 1/2 cup

- Vodka
- Tequila
- Mezcal
- Gin

4-6 SERVINGS

Add 1 cup

- Rum
- Whiskey
- Bourbon
- Brandy

3. SELECT SLUSHIE.

Adjust the temperature for your preferred texture.

4. SERVE & ENJOY!

TIP: Chill liquid before adding it in for best results.

NOTE: Refer to Alcohol Guidelines on page 14 for more info on correct alcohol amounts per recipe.

VANILLA ICE CREAM

Prep:	Total Time:	Serves:
10 Minutes	40-55 Minutes	4 to 6

This creamy and indulgent homemade vanilla ice cream is the perfect treat any time. With just a few simple ingredients, you can create a rich, smooth dessert in less than an hour.

INGREDIENTS

- 2 cups whole milk
- 3/4 cup heavy cream
- 1/2 cup granulated sugar
- 1 1/2 tablespoons vanilla extract
- 1 teaspoon kosher salt

INSTRUCTIONS

1. In a medium mixing bowl whisk together all the ingredients until evenly combined and the sugar begins to dissolve.
2. Pour the mixture into the GreenPan Frost mixing bowl and cover with the mixing bowl cover.
3. Select the Soft Ice Cream Mode and choose level 4. Churn until the Frost switches to Cool and beeps, or until your preferred texture is reached.
4. Serve immediately, or transfer to an airtight freezer safe container and place in the freezer to store.

TIPS & TRICKS

- For the best texture, we recommend using cold ingredients and extruding the finished ice cream as soon as it's done to avoid too much air getting mixed in as it churns.
- If you're a fan of chocolate, this recipe is easy to change - simply replace the 1/2 cup of granulated sugar with an equal amount of your favorite chocolate syrup in the recipe.

PEPPERMINT ICE CREAM

Prep:	Total Time:	Serves:
10 Minutes	40-55 Minutes	4 to 6

Cool, creamy, and packed with flavor, this homemade ice cream is a peppermint lover's dream. A perfect blend of sweet and refreshing, this Peppermint Ice Cream is smooth, satisfying, and effortlessly easy to make.

INGREDIENTS

- 2 cups whole milk
- 3/4 cup heavy cream
- 1/2 cup granulated sugar
- 1 teaspoon kosher salt
- 2 teaspoons peppermint extract, more to taste

INSTRUCTIONS

1. In a medium mixing bowl whisk together all the ingredients until evenly combined and the sugar begins to dissolve.
2. Pour the mixture into the GreenPan Frost mixing bowl and cover with the mixing bowl cover.
3. Select the Soft Ice Cream Mode and choose level 4. Churn until the Frost switches to Cool and beeps, or until your preferred texture is reached.
4. Serve immediately, or transfer to an airtight freezer safe container and place in the freezer to store.

TIPS & TRICKS

- Try lemon, orange or almond extract instead of peppermint to create your own flavors.

APPLE GINGER SORBET

Prep:	Total Time:	Serves:
10 Minutes	40-55 Minutes	6 to 8

A refreshing and slightly spicy treat, this Apple Ginger Sorbet combines the crisp sweetness of apple cider with the warmth of fresh ginger. Perfect for a light dessert or a palate cleanser, it's a delightful balance of flavors in a cool, sorbet form.

INGREDIENTS

- 3 cups apple cider or fresh pressed apple juice
- 1 1/4 cups granulated sugar
- 1 cup water
- 2 tablespoons lemon juice, freshly squeezed preferred
- 1 tablespoons ground ginger

INSTRUCTIONS

1. In a medium mixing bowl, stir all the ingredients until evenly combined and the sugar begins to dissolve.
2. Pour the mixture into the GreenPan Frost mixing bowl and cover with the mixing bowl cover.
3. Select the Sorbet Mode and choose level 4. Churn until the Frost switches to Cool and beeps, or until your preferred texture is reached.
4. Serve immediately, or transfer to an airtight freezer safe container and place in the freezer to store.

TIPS & TRICKS

- The sorbet will have a much smoother texture if the base mixture is chilled before going in the Frost, so we recommend using apple cider straight from the fridge!

ORANGE SORBET

Prep:	Total Time:	Serves:
10 Minutes	40-55 Minutes	6 to 8

Bright and citrusy, this Orange Sorbet is a zesty, refreshing dessert that brings the perfect balance of sweetness and tartness. Made with fresh-squeezed orange juice and a hint of lemon, it's an easy way to enjoy a cool, tangy treat any time.

INGREDIENTS

- 3 cups fresh squeezed orange juice, strained if squeezed at home
- 1 1/2 cups granulated sugar
- 1 cup water
- 1/4 cup lemon juice, freshly squeezed preferred

INSTRUCTIONS

1. In a medium mixing bowl, stir all the ingredients until evenly combined and the sugar begins to dissolve.
2. Pour the mixture into the GreenPan Frost mixing bowl and cover with the mixing bowl cover.
3. Select the Sorbet Mode and choose level 4. Churn until the Frost switches to Cool and beeps, or until your preferred texture is reached.
4. Serve immediately, or transfer to an airtight freezer safe container and place in the freezer to store.

TIPS & TRICKS

- Whether fresh squeezed or store bought, for a better sorbet texture straining out any large pieces of pulp in the orange juice is key!

CHOCOLATE MILKSHAKE

Prep:	Total Time:	Serves:
10 Minutes	35-50 Minutes	4 to 6

This Chocolate Milkshake is a creamy, indulgent classic churned to the perfect texture. Simple to make and delightfully rich, it's an easy dessert everyone will love.

INGREDIENTS

- 2 2/3 cups milk
- 1 cup heavy cream
- 1/2 cup chocolate syrup
- 3 tablespoons simply syrup or light agave
- 1 teaspoon vanilla extract

INSTRUCTIONS

1. In a medium mixing bowl whisk together all the ingredients until evenly combined.
2. Pour the mixture into the GreenPan Frost mixing bowl and cover with the mixing bowl cover.
3. Select the Milkshake Mode and choose level 3. Churn until the Frost switches to Cool and beeps, or until your preferred texture is reached.
4. Serve immediately in a chilled glass.

TIPS & TRICKS

- This recipe works great with strawberry syrup or caramel syrup too!

COFFEE MILKSHAKE

Prep:
5 Minutes

Total Time:
35-50 Minutes

Serves:
4 to 6

This Coffee Milkshake is a creamy and refreshing blend of cold brew, milk, and cream for the perfect balance of richness and bold coffee flavor. Quick to make and satisfyingly smooth, it's an ideal treat for coffee lovers.

INGREDIENTS

- 2 cups cold brew coffee
- 2 cups heavy cream
- 1/2 cup whole milk
- 1/2 cup simple syrup or light agave
- 1 teaspoon vanilla extract, optional

INSTRUCTIONS

1. In a medium mixing bowl whisk together all the ingredients until evenly combined.
2. Pour the mixture into the GreenPan Frost mixing bowl and cover with the mixing bowl cover.
3. Select the Milkshake Mode and choose level 3. Churn until the Frost switches to Cool and beeps, or until your preferred texture is reached.
4. Serve immediately in a chilled glass.

TIPS & TRICKS

- Regular coffee can be used instead of cold brew, just make sure it's fully chilled before using!
- If you'd like to make a spiked chocolate milkshake, add your favorite coffee liquor using the Hard Alcohol/Spirit Guidelines from Page 14.

CLASSIC FROZEN CUSTARD

Prep:	Total Time:	Serves:
35 Minutes	60-80 Minutes	4 to 6

This Classic Frozen Custard delivers a rich, creamy texture and subtle vanilla flavor, making it a timeless dessert favorite. Perfectly smooth and luxurious, it's the ultimate base for toppings or a stand-alone treat.

INGREDIENTS

- 2 cups heavy cream
- 1 cup whole milk
- 2/3 cup granulated sugar, divided
- 1/2 teaspoon kosher salt
- 6 large egg yolks
- 1 teaspoon vanilla extract

INSTRUCTIONS

1. In a medium saucepan, gently heat the heavy cream, milk, half the sugar and salt over medium heat for 4 to 6 minutes, stirring regularly, or until it comes to a light simmer and the sugar fully dissolves. Immediately remove from the heat.
2. In a medium heat proof mixing bowl, whisk the remaining half the sugar with the egg yolks and vanilla until fully combined. While whisking very quickly, slowly drizzle half of the warm cream mixture into the egg yolks and sugar. It's very important to incorporate the warm cream mixture slowly so that you don't cook the egg yolks. Pour the yolk mixture back into the saucepan with the remaining warm cream mixture and whisk to combine.
3. Place the saucepan back on the stovetop over medium low heat. Gently cook the custard base, stirring regularly and taking care to scrape the sides and bottom, until the mixture is thick enough to coat the back of a spoon or it reaches 165°F when tested with a thermometer. Strain the custard base into a clean bowl through a fine mesh strainer and cool in the refrigerator to at least room temperature.
4. Pour the cooled custard base into the GreenPan Frost mixing bowl and cover with the mixing bowl cover. Select the Soft Ice Cream Mode and choose level 5. Chill until the Frost switches to Cool and beeps, or until your preferred texture is reached.
5. Serve immediately, or transfer to an airtight freezer safe container and place in the freezer to store.

TIPS & TRICKS

- The custard base should cool to room temperature in 20 to 25 minutes, but the cooler the better for the final texture of the frozen custard – so give it more time if needed!

CARAMEL FROZEN CUSTARD

Prep:	Total Time:	Serves:
35 Minutes	60-80 Minutes	4 to 6

This Caramel Frozen Custard combines rich cream, velvety caramel, and the perfect hint of vanilla for an indulgent, silky dessert.

INGREDIENTS

- 2 cups heavy cream
- 1 cup whole milk
- 1/2 teaspoon kosher salt
- 1/3 cup granulated sugar
- 6 large egg yolks
- 1 teaspoon vanilla extract
- 1/3 cup caramel sauce, store bought or homemade

INSTRUCTIONS

1. In a medium saucepan, gently heat the heavy cream, milk, and salt over medium heat for 4 to 6 minutes, stirring regularly, or until it comes to a light simmer. Immediately remove from the heat.
2. In a medium heat proof mixing bowl, whisk the sugar with the egg yolks and vanilla until fully combined. While whisking very quickly, slowly drizzle half of the warm cream mixture into the egg yolks and sugar. It's very important to incorporate the warm cream mixture slowly so that you don't cook the egg yolks. Pour the yolk mixture back into the saucepan with the remaining warm cream mixture and whisk to combine.
3. Place the saucepan back on the stovetop over medium low heat. Gently cook the custard base, stirring regularly and taking care to scrape the sides and bottom, until the mixture is thick enough to coat the back of a spoon or it reaches 165°F when tested with a thermometer. Strain the custard base into a clean bowl through a fine mesh strainer, then whisk in the caramel sauce until combined and cool in the refrigerator to at least room temperature.
4. Pour the cooled custard base into the GreenPan Frost mixing bowl and cover with the mixing bowl cover. Select the Soft Ice Cream Mode and choose level 5. Chill until the Frost switches to Cool and beeps, or until your preferred texture is reached.
5. Serve immediately, or transfer to an airtight freezer safe container and place in the freezer to store.

TIPS & TRICKS

- This recipe also works great by using chocolate or strawberry syrup instead of caramel sauce! The texture can be a bit thinner though, so you may need to select level 6 or 7 when churning.

VANILLA FROZEN YOGURT

Prep:	Total Time:	Serves:
10 Minutes	40-55 Minutes	4 to 6

An absolute classic, this Vanilla Frozen Yogurt is easy to make and sure to be a favorite in your house for special meals and every day treats alike!

INGREDIENTS

- 2 cups plain yogurt (not Greek style)
- 1 cup heavy cream
- 1/2 cup light agave or simple syrup
- 1 1/2 tablespoons vanilla extract
- 1/2 teaspoon kosher salt

INSTRUCTIONS

1. In a medium mixing bowl whisk together all the ingredients until evenly combined.
2. Pour the mixture into the GreenPan Frost mixing bowl and cover with the mixing bowl cover.
3. Select the Soft Ice Cream Mode and choose level 3. Churn until the Frost switches to Cool and beeps, or until your preferred texture is reached.
4. Serve immediately, or transfer to an airtight freezer safe container and place in the freezer to store.

TIPS & TRICKS

- Different yogurts can have different percentages of fat, so while almost any can be used, we recommend keeping an eye on it as it churns so you can adjust as needed for your preferred texture!
- To enjoy a chocolate or strawberry frozen yogurt, simply replace the 1/2 cup of agave/simple syrup with an equal amount of your favorite chocolate or strawberry syrup.

HONEY FROZEN YOGURT

Prep:	Total Time:	Serves:
10 Minutes	40-55 Minutes	4 to 6

This Honey Frozen Yogurt is a creamy, subtly sweet dessert made with rich honey and a hint of vanilla. Perfectly smooth and simple, it's an elegant treat for any time or occasion.

INGREDIENTS

- 2 cups plain yogurt (not Greek style)
- 1 cup heavy cream
- 1/2 cup honey
- 2 teaspoons vanilla extract
- 1/2 teaspoon kosher salt

INSTRUCTIONS

1. In a medium mixing bowl whisk together all the ingredients until evenly combined.
2. Pour the mixture into the GreenPan Frost mixing bowl and cover with the mixing bowl cover.
3. Select the Soft Ice Cream Mode and choose level 3. Churn until the Frost switches to Cool and beeps, or until your preferred texture is reached.
4. Serve immediately, or transfer to an airtight freezer safe container and place in the freezer to store.

TIPS & TRICKS

- For the best results it's important to make sure the honey is fully incorporated before going in the machine, so make sure to give it a really good whisk!

ROSE & CARDAMOM FROZEN YOGURT

Prep:
10 Minutes

Total Time:
40-55 Minutes

Serves:
4 to 6

This Rose and Cardamom Frozen Yogurt combines the creamy richness of yogurt and heavy cream with delicate rosewater and warm cardamom flavors. Topped with toasted pistachios, it's an elegant, floral dessert perfect for any occasion.

INGREDIENTS

- 2 cups plain yogurt (not Greek style)
- 1 cup heavy cream
- 1/2 cup simple syrup or light agave
- 1 tablespoon rosewater, more to taste
- 1/2 teaspoon ground cardamom
- 1/2 teaspoon kosher salt

INSTRUCTIONS

1. In a medium mixing bowl whisk together all the ingredients until evenly combined.
2. Pour the mixture into the GreenPan Frost mixing bowl and cover with the mixing bowl cover.
3. Select the Soft Ice Cream Mode and choose level 3. Churn until the Frost switches to Cool and beeps, or until your preferred texture is reached.
4. Serve immediately, or transfer to an airtight freezer safe container and place in the freezer to store.

TIPS & TRICKS

- If rosewater isn't your favorite, we love this recipe orange blossom water too!

CRANBERRY ORANGE SLUSHIE

Prep:
5 Minutes

Total Time:
35-50 Minutes

Serves:
4 to 6

A vibrant and tangy blend of cranberry and orange juices, this slushie is a burst of refreshing flavor in every sip. Perfectly icy and cooling, it's an easy way to enjoy a fruit-filled treat on a warm day or as a fun, frosty beverage anytime.

INGREDIENTS

- 2 1/2 cups orange juice
- 2 cups cranberry juice
- 1/4 cup granulated sugar

INSTRUCTIONS

1. In a medium mixing bowl stir to combine both juices and the sugar until the sugar begins to dissolve.
2. Pour the mixture into the GreenPan Frost mixing bowl and cover with the mixing bowl cover.
3. Select the Slushie Mode and choose level 4. Churn until the Frost switches to Cool and beeps, or until your preferred texture is reached.
4. Serve in a chilled glass.

TIPS & TRICKS

- For best results, use an orange juice without pulp. Or if freshly squeezing your own, strain out any large bits of pulp.

LEMONADE ICED TEA SLUSHIE

Prep:	Total Time:	Serves:
5 Minutes	35-50 Minutes	4 to 6

Refreshingly tangy and perfectly chilled, this Lemonade Iced Tea Slushie combines the best of both worlds in a cool, slushy form. With just two simple ingredients, it's the ultimate summer treat to keep you refreshed on hot days.

INGREDIENTS

- 3 cups lemonade (not sugar free)
- 2 cups sweetened ice tea

INSTRUCTIONS

1. In a medium mixing bowl stir to combine the lemonade and iced tea.
2. Pour the mixture into the GreenPan Frost mixing bowl and cover with the mixing bowl cover.
3. Select the Slushie Mode and choose level 4. Churn until the Frost switches to Cool and beeps, or until your preferred texture is reached.
4. Serve in a chilled glass.

TIPS & TRICKS

- Having a sweetened ice tea and a lemonade with real sugar is key to this slushie freeze.
- For more fun flavors try strawberry or raspberry lemonades.

SODA SLUSHIE

Prep:	Total Time:	Serves:
5 Minutes	35-50 Minutes	3 to 5

Turn your favorite soda into a refreshing slushie with in minutes. Just pour, churn, and sip your way to instant cool!

INGREDIENTS

- 1 liter soda of your choice (not diet or sugar free), chilled

EXAMPLES

- Cola
- Orange
- Lemon-Lime
- Cream
- Root Beer
- Ginger Ale
- Grape
- Other Flavored Soda

INSTRUCTIONS

1. Pour the soda into the GreenPan Frost mixing bowl and cover with the mixing bowl cover.
2. Select the Slushie Mode and choose level 4. Churn until the Frost switches to Cool and beeps, or until your preferred texture is reached.
3. Serve in a chilled glass.

TIPS & TRICKS

- It's important to use sodas with sugar, as diet sodas or ones with artificial sweeteners won't freeze properly.

FROZEN MOJITO

Prep:	Total Time:	Serves:
25 Minutes	55-70 Minutes	4 to 6

This Frozen Mojito blends the zesty tang of fresh lime juice, the cool aroma of mint, and a touch of white rum into a refreshing slushie drink. Garnished with fresh mint leaves and lime, it's the perfect chilled drink to enjoy on warm, sunny days.

INGREDIENTS

For the mint simple syrup:

- 1/4 cup fresh mint leaves
- 1 cup water
- 1 cup granulated sugar

For the frozen mojito:

- 2 cups water
- 1 1/2 cups lime juice, freshly squeezed preferred
- 1 cup mint simple syrup (from recipe above)
- 3/4 cup white rum fresh mint leaves, for garnish lime wedges or slices, for garnish

INSTRUCTIONS

1. Lightly bruise the mint leaves by squeezing them firmly in your hand. Heat the mint leaves, water and sugar in a small saucepan on the stovetop over medium heat. Cook, stirring occasionally, until the sugar is fully dissolved. Remove from the heat and allow to cool to room temperature, about 15 minutes. Remove the mint leaves and discard. (For extra mint flavor, feel free to use more mint, and allow it to sit longer to cool before discarding the leaves).
2. In a medium mixing bowl or large pitcher, stir the mint simple syrup with the water, lime juice, and rum until evenly combined then pour into the GreenPan Frost mixing bowl and cover with the mixing bowl cover.
3. Select the Spiked Slushie Mode and choose level 4. Churn until the Frost switches to Cool and beeps, or until your preferred texture is reached.
4. Serve in a chilled glass, garnished with a few fresh mint leaves and a lime wedge or slice.

TIPS & TRICKS

- To make this spiked slushie even faster, use store bought simple syrup instead of the homemade mint, and stir 2 to 3 finely chopped mint leaves into the glass right before enjoying.

FROZEN ROSÉ

Prep:
10 Minutes

Total Time:
35-50 Minutes

Serves:
4 to 6

This Frozen Rosé is a refreshing and elegant treat, combining the crisp flavors of brut rosé with a touch of lemon and sweetness. Perfectly slushy and garnished with a lemon twist, it's a sophisticated way to cool down and celebrate any occasion.

INGREDIENTS

- 1 (750ml) bottle brut rosé wine, chilled
- 1 1/4 cups water
- 1/3 cup simple syrup
- 3 ounces lemon juice, freshly squeezed preferred

INSTRUCTIONS

1. In a medium mixing bowl stir or whisk together all the ingredients until evenly combined.
2. Pour the mixture into the GreenPan Frost mixing bowl and cover with the mixing bowl cover.
3. Select the Spiked Slushie Mode and choose level 4. Churn until the Frost switches to Cool and beeps, or until your preferred texture is reached.
4. Serve in a chilled glass.

TIPS & TRICKS

- Chilling the wine is important for the best final result, but for an even smoother texture pop the cork early and allow the rosé to go slightly flat and lose carbonation.

FROZEN WHISKEY SOUR

Prep:
10 Minutes

Total Time:
35-50 Minutes

Serves:
4 to 6

Cool, smooth, and perfectly tangy, this Frozen Whiskey Sour is the perfect mix of a bold kick of bourbon and bright citrus in a refreshingly frosty take on a classic cocktail.

INGREDIENTS

- 2 cups water
- 1 1/4 cups lemon juice, freshly squeezed preferred
- 1 cup simple syrup
- 3/4 cup bourbon
- 1 teaspoon angostura bitters

INSTRUCTIONS

1. In a medium mixing bowl or large pitcher, stir together all the ingredients until evenly combined.
2. Pour the mixture into the GreenPan Frost mixing bowl and cover with the mixing bowl cover.
3. Select the Spiked Slushie Mode and choose level 4. Churn until the Frost switches to Cool and beeps, or until your preferred texture is reached.
4. Serve in a chilled glass.

TIPS & TRICKS

- The ratio of alcohol is important when making spiked slushies. Make sure to check out the section of the guide on alcohol content if you want to play mixologist at home!

FROZEN PALOMA MOCKTAIL

Prep:	Total Time:	Serves:
10 Minutes	35-50 Minutes	4 to 6

This Frozen Paloma Mocktail combines the tangy brightness of pink grapefruit and lime juices with a touch of honey for natural sweetness. Blended into a perfectly slushy texture, it's a refreshing, non-alcoholic take on the classic cocktail, complete with a lime garnish.

INGREDIENTS

- 2 cups freshly squeezed pink grapefruit juice (from 3 to 4 grapefruits)
- 2 cups water
- 1/3 cup lime juice, freshly squeezed preferred
- 1/4 cup honey or light agave syrup – lime wedges or slices, for garnish

INSTRUCTIONS

1. In a medium mixing bowl stir or whisk together all the ingredients until evenly combined.
2. Pour the mixture into the GreenPan Frost mixing bowl and cover with the mixing bowl cover.
3. Select the Slushie Mode and choose level 4. Churn until the Frost switches to Cool and beeps, or until your preferred texture is reached.
4. Serve in a chilled glass, garnished with a lime wedge or slice.

TIPS & TRICKS

- While the honey and agave give the mocktail a great depth of flavor, if you want to highlight the citrus more, substitute simple syrup instead!

FROZEN PIÑA COLADA MOCKTAIL

Prep:
10 Minutes

Total Time:
40-55 Minutes

Serves:
4 to 6

This Frozen Piña Colada Mocktail combines creamy coconut milk, sweet pineapple juice, and a splash of lime for a tropical, refreshing treat. Blended to slushy perfection, it's a non-alcoholic delight perfect for warm days, served with a fresh pineapple garnish.

INGREDIENTS

- 1 (13.5 ounce) can full fat coconut milk, well shaken
- 1 1/2 cups pineapple juice
- 1 cup water
- 1/3 cup lime juice, freshly squeezed preferred
- 3 tablespoons light agave syrup – fresh pineapple spears or wedges, for garnish

INSTRUCTIONS

1. In a medium mixing bowl, whisk the coconut milk until fully smooth with no lumps remaining. Stir or whisk together all the remaining ingredients with the coconut milk until evenly combined.
2. Pour the mixture into the GreenPan Frost mixing bowl and cover with the mixing bowl cover.
3. Select the Slushie Mode and choose level 4. Churn until the Frost switches to Cool and beeps, or until your preferred texture is reached.
4. Serve in a chilled glass, garnished with a pineapple spear or wedge.

TIPS & TRICKS

- This recipe can easily be made into a version with alcohol by simply mixing in an ounce or two of rum per glass before serving!

TROUBLESHOOTING

Issue	Cause	Solution
After the frozen treat is made, it is difficult to remove the bowl	There may have been water in the mixing bowl before the unit was started creating ice behind the bowl.	Wait 10 to 15 minutes for the unit to thaw before trying again.
Your frozen treat is too grainy	There is too much water in your recipe.	Increase, milk, cream or sugar ratio.
Machine Displays "EEE" message	Incorrect ingredient amount or sugar ratio	Increase ingredients to a minimum of 24oz or make sure that there is enough sugar in your mixture.
The machine stops working	Poor exhaust and high internal temperature	The product is too close to the wall, resulting in poor air circulation and high temperature. The product vent should be at least 20cm away from the wall. To solve, wait 10-15mins & try again. If issue persists please contact customer service team.
The recipe is not freezing on spiked slushie mode	High Alcohol or sugar content.	Make sure that the alcohol percentage is not over 16% a higher alcohol content will make the recipe difficult to freeze.
The recipe is not freezing on Slushie, Soft Ice Cream, and Milkshake mode	High sugar content or overfilled mixing bowl	If you are using too high of a sugar content dispense some of the liquid and replace with water or liquid without sugar. If there is too much liquid, the contents will take much longer to freeze and will risk overflowing due to expansion. If issues persist, contact customer service.
Loud sound while product is running	Too little ingredients in the mixing bowl	To stop the loud sound from happening while operating make sure there are enough ingredients in the bowl. If too little the stirring blade will squeak. If you have already finished the recipe and its on cool mode, consider adding more of the based ingredient or dispensing the remaining liquid.
Debris on cooling rod	Use over time and not immediately cleaning after use.	Use the bristle cleaning brush provided to remove the buildup on the cooling rod if a damp cloth does not remove the build up and debris.
Extrude head gaskets lost or broken	Use over time	If a extrude head gasket is ever lost or damaged 2 additional extrude head gaskets are provided for replacement. Slide these extrude head gaskets onto the slots of the extrusion head if either are missing. If issue does not resolve the situation please contact customer service.
Contents not extruding on slushie or sorbet mode	Swirl extrude cover accessory on product	If some recipes are too dense the extrusion head cover accessory can block the contents from extruding particularly for denser water based recipes. We suggest removing this to solve for this issue. If issue persists please contact customer service.
Frost is Leaking from the extrusion Head	Damaged gaskets	If there is a light leak coming from the extrusion head be sure to replace the gaskets with the replacement parts provided. This should stop the leaking. If this does not please contact customer service.

DISHWASHER SAFE GUIDE

Part	Dishwasher Safe	Wipe With a Damp Cloth
Main Body	✗	✓
Mixing Bowl Cover	✗	✓
Mixing Bowl	✓	✓
Removable Decorative Cover	✓	✓
Stirring Blade	✓	✓
Two- Part removable Drip Tray	✓	✓
Extrusion Head	✓	✓
Handle	✗	✓
Handle Fixing Pin	✗	✓
Swirl Extrude Cover Accessory	✓	✓
Bristle Cleaning Brush	✓	✓
Silicone Cleaning Brush/ Installation Rod	✓	✓

All Dishwasher safe parts, are bottom-rack dishwasher safe, and should NOT be cleaned with a heated dry cycle.

STORAGE

- Be sure to store your Frost in an upright and fully assembled when possible.
- Do not store ingredients inside the mixing bowl when storing.
- Keep in a cool, dry place.
- DO NOT carry the unit by the handle. ONLY lift when grasping both sides of the bottom of the main body

LIMITED WARRANTY

GreenPan Electrics are covered by a limited warranty against defects in materials and workmanship, beginning on the date you receive the product and lasting for two years. If your GreenPan Electrics product has a defect covered by the limited warranty during the warranty period, The Cookware Company (USA), LLC will, at its sole option, replace the product or provide a refund. Further information on the warranty claim process, exclusions from warranty coverage, and other terms can be found in the complete limited warranty for this product, available online at greenpan.us/warranty.

TERMS OF SALE; ARBITRATION

The terms on which The Cookware Company (USA), LLC sells GreenPan Electrics are available online at greenpan.us/pages/terms-of-sale (the "Terms"). The Terms contain very important information regarding your rights and obligations, as well as conditions, limitations, and exclusions that may apply to you. Please read them carefully.

In particular, the Terms provide that, by your purchase of this product, you and The Cookware Company (USA), LLC are agreeing to give up any rights to litigate in a court or before a jury, or to participate in a class action or representative action with respect to a claim. Other rights that you would have if you went to court may also be unavailable or limited in arbitration. Any claim, dispute, or controversy between you and The Cookware Company (USA), LLC arising from or relating in any way to your purchase of products or services will be resolved exclusively and finally by binding arbitration.

The arbitration will be administered by the American Arbitration Association ("AAA") in accordance with the Consumer Arbitration Rules (the "AAA Rules") then in effect, except as modified hereby. (The AAA Rules are available at adr.org or by calling the AAA at

1-800-778-7879.) The Federal Arbitration Act will govern the interpretation and enforcement of this arbitration and waiver provision.

The Cookware Company (USA), LLC will be responsible for the AAA filing fee of any such proceeding. Other than your right to pursue a claim in small claims court, as described in the Terms, the arbitrator will have exclusive authority to resolve any dispute relating to arbitrability and/or enforceability of this arbitration provision, including any unconscionability challenge or any other challenge that the arbitration provision or these Terms are void, voidable or otherwise invalid. The arbitrator will be empowered to grant whatever relief would be available in court under law or in equity. Any award of the arbitrator(s) will be final and binding on each of the parties and may be entered as a judgment in any court of competent jurisdiction. Attorney fee shifting in this case is governed by the Terms. You agree to an arbitration on an individual basis. In any dispute, **NEITHER YOU NOR THE COOKWARE COMPANY (USA), LLC WILL BE ENTITLED TO JOIN OR CONSOLIDATE CLAIMS BY OR AGAINST OTHER CUSTOMERS IN COURT OR IN ARBITRATION OR OTHERWISE PARTICIPATE IN ANY CLAIM AS A CLASS REPRESENTATIVE, CLASS MEMBER OR IN A PRIVATE ATTORNEY GENERAL CAPACITY.** The arbitral tribunal may not consolidate more than one person's claims and may not otherwise preside over any form of a representative or class proceeding. The arbitral tribunal has no power to consider the enforceability of this class arbitration waiver and any challenge to the class arbitration waiver may only be raised in a court of competent jurisdiction.

If any provision of the arbitration agreement described herein and in the Terms is found unenforceable, the unenforceable provision will be severed and the remaining arbitration terms will be enforced.



See It In Action:
Scan this code for more recipes,
step-by-step videos and helpful tips.

1400033664