

# Chef'sChoice®

International

## WafflePro® Express® Taste/Texture Select®



WITH  
**Quad**®  
BAKING SYSTEM

### Instructions & Recipes for **Model 840**

# IMPORTANT SAFEGUARDS

**When using electrical appliances, basic safety precautions should always be followed including the following:**

1. Read all instructions before using the WafflePro® Express®.
2. Do not touch hot surfaces. Always use plastic handle on lid and do not touch stainless cover when hot.
3. To protect against fire, electric shock and injury to persons, do not immerse cord, plug or WafflePro® Express® in water or other liquid.
4. Close supervision is necessary when any appliance is used by or near children.
5. Before use, unwind the power cord completely and keep the cord away from hot parts of the appliance.
6. Do not let power cord hang over edge of table or counter or touch hot surfaces.
7. Do not place on or near hot gas or electric burner, or in a heated oven.
8. Extreme caution must be used when moving an appliance containing hot oil or other hot liquids.
9. Only operate the WafflePro® Express® on a dry, flat, non-slip surface.
10. Do not use the WafflePro® Express® outdoors.
11. Do not operate the WafflePro® Express® with a damaged cord or plug. If it malfunctions or has been damaged in any manner, return the WafflePro® Express® to the EdgeCraft Corporation Service Department for examination, repair or adjustment.
12. The use of accessory attachments not recommended by the EdgeCraft Corporation may result in fire, electric shock or injury to persons.
13. Always unplug the WafflePro® Express® from electrical outlet when not in use and before cleaning, to avoid accidental electrical shock. Allow to cool before cleaning.
14. As long as the appliance is hot, even if unplugged, there is the danger of someone getting burned. Do not touch and do not put it into storage while hot.
15. Do not use the WafflePro® Express® for other than intended use.
16. For use only on 120V 60HZ power. Use a socket with a good ground connection. Do not use a three to two way adapter on the three prong power cord provided.
17. For household use only.
18. **SAVE THESE INSTRUCTIONS.**

# YOU MADE A GOOD CHOICE

---

**T**he WafflePro® Express® Taste/Texture Select® Model 840 comes to you from Chef'sChoice®, the maker of the world's finest professional household gourmet products. The WafflePro® Express brings to the home features found only in commercial waffle makers. Its unique Quad® Baking System allows you to select that "just right" texture and taste. A highly versatile waffle maker, WafflePro® Express® will for example bake rapidly for a crisp golden brown exterior while retaining a moist interior, like crusty bread hot from the oven. Or, with the flick of a switch, you can make a crunchy waffle with a uniform texture throughout.

Remember when waffles were only for the weekends when Mom and Dad had more time? The WafflePro® Express® puts waffles back on the menu everyday! It heats up while the coffee is being brewed and your first waffle is ready when your coffee is poured. And, because it heats so rapidly, you'll be making waffles just about as fast as they can be eaten.

Imagine waffles with the natural aroma and taste of freshly baked bread and pastries. Make up a batch of a quick Basic Waffle recipe the night before so it's ready to bake in the heated WafflePro® Express® every morning. Enjoy!

## GETTING TO KNOW THE WafflePro® Express®

Take a minute to identify the key features and controls of WafflePro® Express®, (Figure 1) made of high strength, high temperature engineering plastics with a polished stainless steel lid.

To open the lid, pull forward the front latch and lift by the insulated front plastic handle. Electronic controls are on the control panel, Figure 2.

Take a moment to understand the use of the circular black Rocker Switch, Figures 1 and 2. Press the upper portion of the rocker switch for a fast bake and for waffles with “Crisp Exterior/Moist Interior”, or press at the bottom of the rocker switch for a deep bake and for waffles that have a more “Uniform Texture” throughout.

Above the rocker switch is a red light marked “Baking” to indicate when the waffle plates are being heated. Below that is a green light marked “Ready” to indicate either that the waffle plate is at baking temperature or that the waffle is “Ready” to be removed and served.

An audible “Ready Beeper” sounds when the green light comes on to further indicate when the waffle is ready to serve.

The color control dial is graduated numerically. The waffle will be darker or lighter in color depending on the exact setting of this wheel and the position of the rocker switch. This control wheel is relatively sensitive and fractional numerical changes can make a notable difference in color. The optimum exact setting for the color control depends on the type of waffle you are baking. To darken the waffle, move toward a higher number; to lighten, turn to a lower number.

A unique suspension system allows the lid to raise evenly in order to maintain a uniform thickness of the waffle as it bakes and rises.

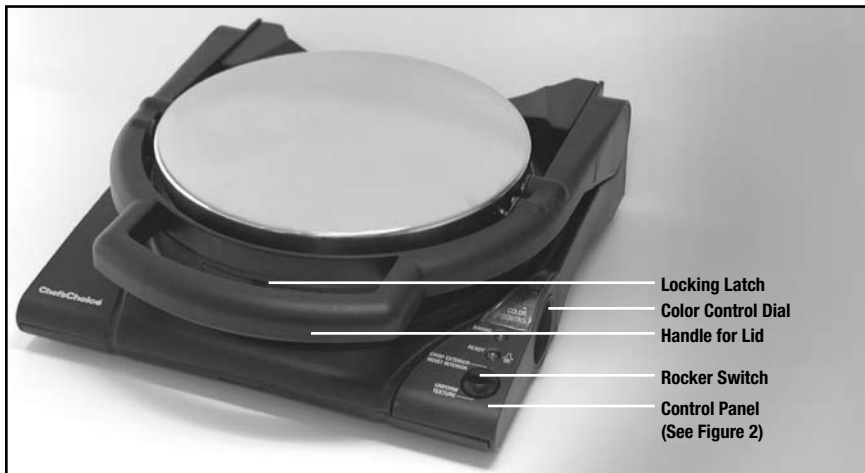

Figure 1. WafflePro® Express Taste/Texture Select®.

Provision has been made for cord storage as described in Storage Section. The cord can be stored under the WafflePro® Express® secured by clips molded under the base.

The WafflePro® Express® can be stored upright to save shelf space. Simply close the lid and stand it upright resting on the flat hinged end.

## **USING WafflePro® Express® FOR FIRST TIME**

Insert the power cord into a grounded 120 volt outlet and close the cover. The red “baking” light will turn on indicating the waffle plates are heating. Set the color control dial to 4. You can shorten the warm-up time by pressing the top of the black circular rocker switch adjacent to the marking “Crisp Exterior/ Moist Interior.”

In about 3½ minutes the red light will turn off, the green Ready light will turn on and the Beeper will sound indicating the waffle plates are up to temperature and ready for baking. On the first heating you may sense a slight odor during the heat-up cycle, typical of new heating elements with non-stick surface coatings.

When “Ready”, open the lid and brush or spray a light coating of non stick vegetable or corn oil on the entire surface area of both the upper and lower heated grids (or you may use non-stick cooking spray). Because both of the baking surfaces are factory finished with an anti-stick coating, it is necessary to oil the surfaces only before the first time you use the WafflePro® Express® and after long periods of storage. It should not be necessary to otherwise oil again.

Pour about 1/3 cup of waffle batter onto the middle of the lower grid and close the lid. Discard the first waffle as it will absorb any excess oil which you used on the grids.

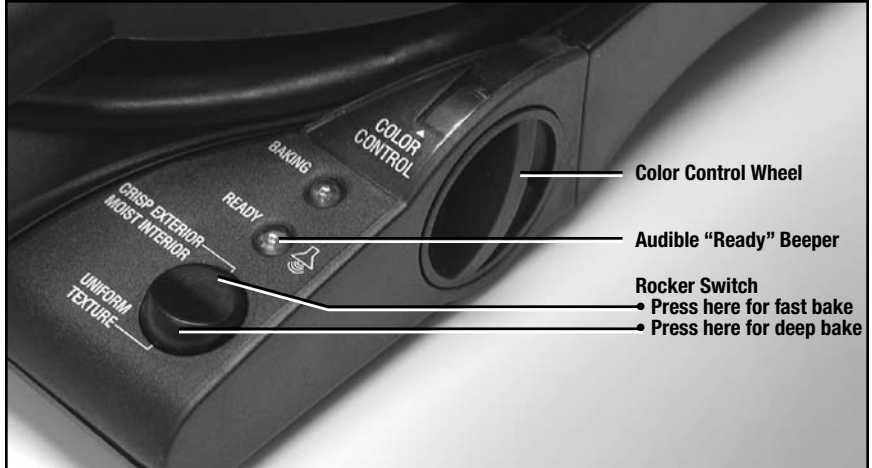

Figure 2. Control Panel.

## **WARM UP AND BAKING PROCEDURE**

---

If the WafflePro® Express® has not been used before, follow instructions above for “Using WafflePro® for First Time.”

If you are looking for a good recipe, see “Some Favorite Recipes”, (page 9).

### **WARM-UP**

Plug the power cord into a grounded 120 volt outlet. Set the rocker switch to “Crisp Exterior/ Moist Interior” to begin the heat-up cycle. This setting places maximum heat on the waffle grids and they will warm up in only 3½ minutes. If the switch is set to Uniform Texture, warm up time will be about twice that long. The red “Baking” light will come on when the WafflePro® is plugged in. Set the color control wheel between 2 and 3. When the heat-up period is complete the red light will go off, the green “Ready” light will come on and the beeper will briefly sound to remind you the grid is up to temperature and ready for you to begin baking. When the green light comes on, the heaters are deactivated until the grids cool slightly below the baking temperature.

Keep hands away from the hot stainless cover and grid surfaces. Touch only the plastic parts and handle provided.

### **SELECT THE TASTE/TEXTURE – WHICH IS JUST RIGHT FOR YOU**

The versatile Quad® Baking System unique to the WafflePro® Express® lets you control the baking condition best suited to your taste and allows you to vary and modify the taste, texture and aroma of the waffles any time you wish. By adjusting the batter you can further widen the flavors and textures available. You can develop the perfect combination of settings for each recipe and for any of your favorite toppings. **Caution - Do not rely on the age-old notion that the waffle is done when the waffle maker stops steaming.** Because of the unique Quad® Baking System the waffle may be ready to serve while the WafflePro® is still steaming. Learn to rely on the green light and beeper and vary the settings to your taste.

### **MAKING WAFFLES WITH CRISP EXTERIOR/ MOIST INTERIOR**

Waffles made with the Crisp Exterior/Moist Interior setting will retain more of the freshly-baked aroma and flavor. The degree of exterior crispness will depend on the recipe and the color control setting.

1. Depress the upper portion of the black circular rocker switch marked “Crisp Exterior/Moist Interior.” Set the color control between 2 and 3 for the first waffle.
2. Pour or ladle about 1/3 level cup of batter from a ladle or pitcher in the middle of the lower waffle grid. A thicker batter, that pours slowly works best. Avoid putting too much batter on grid as that will cause an overflow and increase clean up time.
3. Close the lid and latch immediately after adding batter so as to spread out the batter uniformly. Press down lightly on the lid handle for several seconds in order to help level the batter. The unique suspension system allows the lid to float and adjusts automatically to insure a uniform thickness of the waffle.
4. The red light will come on indicating the waffle is baking. This means the heater is powered to continue the cooking process.
5. When the waffle is ready, the green light comes on, the red light goes off, and the beeper sounds briefly.

6. Open the latch, lift the lid slightly and inspect the waffle color. If necessary close the lid and continue heating a little longer until desired color is obtained. On the next baking cycle adjust the color control dial as necessary to obtain a better setting. Movement to a higher number will darken the waffle. Commonly the necessary adjustment is less than one whole number.
7. When the waffle is done, remove it by lifting one edge with a heat-resistant plastic fork or spatula. (If you use a metal fork, use care not to contact grid surfaces as that might scratch the non-stick surface and decrease its effectiveness.)
8. After removal of waffle, the WafflePro® Express® can be immediately refilled with batter or it can be closed until you are ready to bake again. If you do not start another waffle immediately the green light will stay on until the grids cool slightly, then the red light will come on briefly indicating the grids are being reheated to maintain readiness for the next use. When the green light comes on again the next waffle can be poured and baked.
9. When finished baking, be certain to unplug the WafflePro® Express®. Only then is the power to the waffle maker switched off.

### **MAKING WAFFLES WITH UNIFORM TEXTURE**

Waffles made with the “Uniform Texture” baking cycle will be evenly baked throughout their thickness. They will have a crunchy and drier texture. The amount of moisture retention will depend on the color control setting. Generally the color control setting will be lower and the baking time will be about twice that expected with the “Crisp Exterior/Moist Interior” setting.

1. Depress the lower portion of the black circular rocker switch marked “Uniform Texture”. Set the color control dial to about 2 for the first waffle.
2. Pour or ladle about 1/3 level cup of batter from a ladle or pitcher in the middle of the lower waffle grid. A thicker batter, that pours slowly works best. Do not overfill the grid.
3. Close the lid immediately after adding the batter so that the lid will level out the batter.
4. The red light will come on within 30 seconds indicating the waffle is baking.
5. When the waffle is ready the red light goes off, the green light comes on, and the beeper sounds briefly.
6. Lift the lid and inspect the waffle. If you want a slightly browner waffle, close the lid and cook for another 20 seconds or so.
7. When color is right, remove waffle with a plastic spatula or fork. As needed, increase or decrease the color control for the next cycle. Once you establish the optimum color setting, it will not require any change in the future unless you alter the waffle recipe or switch to “Crisp Exterior/ Moist Interior.”
8. Add batter for the next waffle or close lid until you are again ready to bake. The green light will remain on until the waffle plates cool slightly. Then the red light will alternately come on to keep the grids hot until you are ready for the next waffle.
9. When finished baking, be certain to unplug the WafflePro® Express®. Only then is the power to the waffle maker switched off.

***Always unplug the WafflePro® Express® immediately after use. Never leave it unattended when plugged in. Children should not be allowed to use a waffle maker except in the presence of an attentive adult.***

The waffle maker cools faster when its lid is left fully open. Store only when cold. Save shelf space by storing the WafflePro® Express® upright resting on its hinged flat end.

## **WAFFLE BASICS**

---

Superb waffles begin with a good recipe but depend on a versatile waffle maker to fully develop the flavor, texture and aroma. A perfect waffle is no accident. It is the combination of a brownish crisp exterior and an interior texture baked the way you like it. Some of us prefer a waffle with a moist interior like freshly baked bread. Such a waffle has the greatest flavor and aroma. Others want a uniformly crunchy waffle, one that is baked slowly with less interior moisture. You may like to bake breakfast waffles that are crisp on the outside and fluffy inside or you may want a chocolate dessert waffle, destined to be served with a scoop of ice cream, that is crunchy throughout.

The WafflePro® Express® incorporates the unique Quad® baking system to ensure a waffle baked the way you prefer. You select either a fast bake or a deep bake. Then you select a color control setting. And the color control adjusts for either baking setting to give you a toasty, brown exterior and the interior texture you want.

The Quad® baking system on the WafflePro® Express® works as follows: The “Crisp Exterior/Moist Interior” setting gives you a fast bake while the “Uniform Texture” setting gives a slow deep bake. The Color Control setting controls the surface temperature of the waffle and determines its color.

To get a crisp exterior with a contrasting steamy aromatic interior, you need a waffle iron with a fast bake. The WafflePro® Express® is unique among all waffle makers in its ability to cook rapidly enough to create this delectable combination.

### **WAFFLE INGREDIENTS AND TECHNIQUES**

Sugar in waffle batter enhances the browning of the waffle especially on the surface where the temperatures are highest. If your diet permits, a small amount of sugar can do wonders for the waffles.

Cornmeal in waffle batter adds extra crunch. Only a few tablespoons are needed to add texture.

Butter and oil enhance flavor and can increase the darkening of the waffle. But too much liquid inhibits surface browning.

Eggs add their own flavor to the mix and importantly they reduce the tendency of waffles to “split”.

The consistency of your batter will effect the end result. A slightly thick batter, one which pours slowly, some say like slow moving lava, works the best. If the batter pours freely, add more flour to thicken.

Regardless of the recipe, the WafflePro® Express® works best with a level  $\frac{1}{3}$  cup of batter. This amount fills the waffle iron without risk of overflow. Use a measuring cup, a pitcher or ladle to pour batter onto the WafflePro® grids.

When making waffle batter, add milk slowly and mix with a power mixer or by hand until the right consistency is reached. You may not need to use all of the milk or liquid called for in a recipe. If you add too much liquid, simply stir in additional flour (or dry mix) to thicken the batter.

Some recipes may call for separating the eggs, beating the whites and folding them in at the end of the mix. This step gives a slightly lighter waffle with a less uniform texture but it is not essential. Whole eggs may be used.



Always fully preheat the WafflePro® Express® before adding the batter. Set the Color Control between 2 and 3 if you are just getting started, otherwise set it to your own preference. Read the instructions beginning on Page 4 before making your first waffles.

Remember, when the green light and beeper signal that the waffle is “Ready”, you can briefly lift the lid to check the degree of browning and, if desired, close the lid to bake the waffle for another 20 to 30 seconds for more crispness.

Because this waffle maker heats and bakes so rapidly on the “Crisp Exterior/Moist Interior” setting, you will be able to prepare waffles about as fast as they can be eaten. Waffles taste best “hot off the griddle” but you might let them cool on a wire rack for 20 to 30 seconds before serving. This gives the waffle a chance to release some steam and stiffen slightly. (If a waffle is placed directly on a plate, the steam condenses under the waffle causing the crisp exterior to soften.)

For an express breakfast, it is hard to beat our Basic Waffle recipe prepared from a packaged mix. Try the European Home Style Waffle if you like the flavor of buttermilk. Whichever recipe you choose, serve the waffles hot, spread with butter, maple syrup or your favorite jams, jellies or fruit. Chef’sChoice® offers a Gourmet Waffle Mix formulated just for waffles, richly flavored and ready to use with addition of only water.

## **SOME FAVORITE RECIPES**

---

### **Basic Wheat Flour Waffles**

---

A simple recipe which produces a light and crisp waffle.

**2 cups all-purpose flour**

**3 tablespoons sugar**

**1 tablespoon baking powder**

**1 teaspoon salt**

**2 eggs**

**¼ cup melted butter**

**1¼ -1½ cups milk, as needed**

Makes 6-7 waffles

1. Place the flour, sugar, baking powder and salt in a small bowl. Stir with a wire whisk to evenly distribute the ingredients. Add the melted butter, eggs and about 1½ cups of milk. Blend with a wire whisk until smooth and free from lumps. Batter should be thick but still pour slowly from a ladle or measuring cup. Add more milk as needed to obtain a thick but pourable consistency. If the batter becomes too thin, stir in a teaspoon or two of additional flour.
2. Preheat the WafflePro® Express® at: “**Crisp Exterior/Moist Interior**” @ Color Control 2 - 3 or “**Uniform Texture**” @ Color Control 2
3. Pour a level ⅓ cup of batter onto center of preheated waffle grid. Close the lid, press it down lightly to level batter. Bake until the signals indicate waffle is done.
4. Remove waffle and place on a wire rack for about 30 seconds, then serve immediately.

*Note: Waffles may be kept warm in a preheated 300°F oven for 5 to 10 minutes but their consistency may change. Batter can be held overnight under refrigeration. If it thickens, add milk to restore to the desired consistency.*

## Basic Waffles Using Packaged Mix \*

---

There are many commercial mixes available at your favorite grocer that are excellent and can save preparation time. The flavors will vary slightly. Use the recipe on the box or mix as follows:

- 2 cups prepared pancake or waffle mix**
- 1 egg**
- 2 tablespoons vegetable oil**
- 2 tablespoons of sugar (adjust to your taste)**
- 1 teaspoon vanilla**
- 1 cups milk, as needed**

Makes 6-7 waffles

1. Place the waffle mix, egg, vegetable oil, vanilla and sugar in a small bowl. Add about 1 cup of the milk. Blend with a wire whisk until smooth and free from lumps. Batter should be thick but still pour slowly from the measuring cup. If the batter seems too thick add as much of the additional milk as needed to obtain the right consistency. If it is too loose, stir in a teaspoon or two of pancake mix.
2. Preheat the WafflePro® Express® at: “**Crisp Exterior/Moist Interior**” @ Color Control 2 - 3 or “**Uniform Texture**” @ Color Control 2
3. Pour a level  $\frac{1}{3}$  of a cup waffle batter onto center of preheated waffle grid. Close the lid and bake until signal indicates waffle is done.

*\*A wide variety of trademarked mixes are available including General Mills Bisquick®, Pillsbury Hungry Jack® and Quaker Oats Aunt Jemima®. Chef'sChoice® Gourmet Waffle Mix™ is ready to use and does not require additives other than water.*

4. Remove waffle and place on a wire rack for about 30 seconds then serve immediately.

*Note: Waffles may be kept warm in a preheated 300° F oven for 5 to 10 minutes but their consistency may change.*

This batter works equally well if made the night before, stored covered in the refrigerator. If it thickens, stir in additional milk to restore the desired consistency.

## Delicious Fruit Additions to the Basic Waffle Recipes

---

### Spicy Banana

Fold in  $\frac{1}{2}$  cup of mashed ripe bananas and  $\frac{1}{2}$  teaspoon cinnamon.

### Country Apple

Fold in  $\frac{1}{4}$  cup of finely chopped (peeled) apples and  $\frac{1}{4}$  cup of chopped pecans or walnuts.

### Blueberry

Fold in  $\frac{1}{2}$  cup Maine (small) blueberries and a pinch of nutmeg.

## European Home Style Waffles

---

For those who like the tang of buttermilk, this recipe makes a light waffle with a delicate golden color.

**2 cups all purpose flour**

**½ teaspoon baking soda**

**1 ½ teaspoons baking powder**

**½ teaspoon salt**

**2 tablespoons sugar**

**½ cup buttermilk**

**2 eggs, separated**

**4 tablespoons butter, melted**

**1 cup milk, more if needed**

Makes 6-7 waffles

1. Stir together the flour, baking soda, baking powder, salt and sugar. Set aside.
2. In a small bowl combine the egg yolks, buttermilk, milk and melted butter Using a rubber spatula, gently fold the liquid into the dry ingredients,
3. In a separate bowl, beat the egg whites until they are foamy and hold soft peaks. Gently, fold the egg whites into the batter.
4. Preheat the WafflePro® Express® at: **“Crisp Exterior/Moist Interior”** @ Color Control 3 or **“Uniform Texture”** @ Color Control 2.
5. Pour about a level 1/3 cup waffle batter onto center of preheated waffle grid. Close the lid and bake until signal indicates waffle is done.
6. Remove waffle and place on a wire rack for about 30 seconds, then serve immediately.

*Note: Waffles may be kept warm in a preheated 300°F oven for 5 to 10 minutes, but their consistency may change.*

## Cornmeal Waffles

---

The crunchy yet airy texture of this waffle is matched by its excellent taste.

**1½ cups all purpose flour**

**½ cup yellow cornmeal**

**1 tablespoon baking powder**

**2 tablespoons sugar**

**1 teaspoon salt**

**½ teaspoon baking soda**

**2 eggs, lightly beaten**

**5 tablespoons vegetable oil**

**1 cup milk, depending on batter consistency**

Makes 5-6 waffles

1. Combine all dry ingredients in a large bowl. Stir to blend well.
2. Make a well in the center of the dry ingredients. Add the eggs and oil. Slowly pour in the milk, mixing constantly until a thick batter is obtained.
3. Preheat the WafflePro® Express® at: **“Crisp Exterior/Moist Interior”** @ Color Control 3 or **“Uniform Texture”** @ Color Control 2
4. Pour about a level ⅓ of a cup waffle batter onto center of preheated waffle grid. Close the lid and bake until signal indicates waffle is done.
5. Remove waffle and place on a wire rack for about 30 seconds then serve immediately.

*Note: Waffles may be kept warm in a preheated 300°F oven for 5 to 10 minutes but their consistency may change.*

If you prefer more of a cornbread style waffle, substitute more cornmeal for some of the flour in the recipe. ½ cup of flour to 1½ cups of cornmeal is ideal. Add more milk to make a thick batter and bake as directed.

# RECIPES FOR THE CHOCOLATE LOVER

---

## Chocolate Chip Waffle

---

A light waffle full of chocolate surprises, this recipe is sure to become one of your family's favorites.

- 2 cups all purpose flour**
- 2 tablespoons sugar**
- 2 teaspoons baking powder**
- ½ teaspoon salt**
- 2 eggs, lightly beaten**
- 4 tablespoons vegetable oil**
- ½ cup small chocolate chips**
- 1 cup milk**

Makes about 6 waffles

1. Combine all dry ingredients in a large bowl. Stir to blend well.
2. Add the eggs and oil then slowly pour in the milk while stirring constantly with a rubber spatula. Add just enough milk to make a batter which mounds slightly when poured. Stir in the chocolate chips and blend to distribute them evenly.
3. Preheat the WafflePro® Express® at: “**Crisp Exterior/Moist Interior**” @ Color Control 2 - 3 or “**Uniform Texture**” @ Color Control 2
4. Spoon a level ⅓ cup waffle batter onto center of preheated waffle grid. Close the lid and bake until signal indicates waffle is done.
5. Remove waffle and place on a wire rack to cool for about 30 seconds then serve immediately.
6. This batter may leave some melted chocolate on the waffle grids. To clean, let the WafflePro® cool and wipe off chocolate with a warm moist cloth.

*Note: Waffles may be kept in a preheated 300°F oven for 5 to 10 minutes but their consistency may change.*

For a lighter waffle, the eggs in this recipe can be separated and the yolks added to the batter along with the milk. The whites can be beaten stiff, then folded into the batter.

## Waffle Brownies

---

The child in everyone will love this waffle as a tea-time snack or baked-to-order dessert. For a special treat, serve these with whipped cream, or in a Brownie Sundae with ice cream and hot fudge sauce.

**Superb!!**

**3 oz. (3 squares) unsweetened chocolate melted**

**½ cup (8 tablespoons), butter or shortening, melted**

**3 eggs**

**½ teaspoon salt**

**⅔ cup sugar**

**1 teaspoon vanilla**

**1 ½ cups all purpose flour**

**½ - ¾ cup chopped nuts, (walnuts or pecans)**

**1 cup milk**

**powdered sugar, optional**

Makes about 5-6 waffles

1. Preheat the WafflePro® Express® at: "**Crisp Exterior/Moist Interior**" @ Color Control 3 or "**Uniform Texture**" @ Color Control 2
2. Place the chocolate and butter or shortening in a small saucepan. Melt over low heat. Set aside to cool.
3. In a separate bowl, beat the eggs and salt until light in color. Add the sugar and vanilla. Beat by hand to combine then fold in the cooled chocolate mixture.
4. Stir in the flour and nuts. Slowly add just enough milk to make a thick batter spoonable into the waffle grid.
5. Spoon a level ⅓ cup waffle batter onto center of preheated waffle grid. Close the lid and bake until signal indicates waffle is done.
6. Remove waffle and serve immediately. Dust with powdered sugar if using.

*Note: Waffle brownies will store well for several days if wrapped in plastic.*

## CORD SAFETY

A short power supply cord is provided with this appliance to reduce the risk resulting from the cord becoming entangled in or tripping over a longer cord and causing the WafflePro® Express® to overturn, spilling its hot contents. While EdgeCraft does not recommend it, extension cords are available and may be used if care is exercised in their use. If an extension cord is used, it must have an integral ground wire, a three prong plug and the marked electrical rating of the extension cord should be at least 10 amperes. The longer cord should be arranged so that it will not hang over the counter top or tabletop where it can be pulled on by children or pets or tripped over.

## CLEANING AND STORAGE

Before cleaning the WafflePro®Express, always unplug the power cord. Wait until the wafflemaker cools to room temperature. Never clean the appliance under water. If you find it necessary to clean the baking surface use a soft brush, a moist Q-tip, or a flexible moist cloth. Never use sharp or pointed tools as they will damage the anti-stick surfaces. The exterior can be safely cleaned with a mild detergent on a damp soft cloth, a Q-tip, or small soft brush. Then use a dampened cloth followed by drying with a dry soft cloth.

Store the power cord under the bottom as shown in Figure 3. You will find it is easy to store vertically resting on the top hinged face as shown.

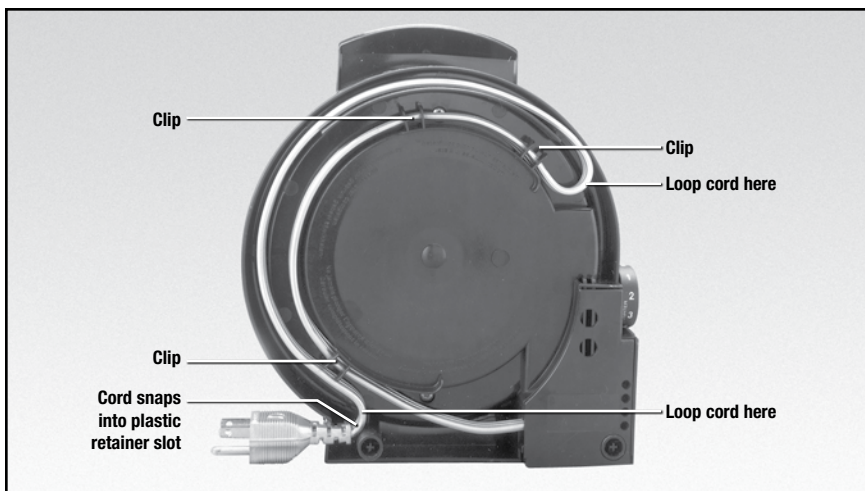

Figure 3. Cord clips under base. WafflePro® Express stores upright as shown

## SERVICE

---

This appliance is for household use only. No user-serviceable parts are inside. Refer servicing to qualified personnel.

In the event service is needed, return your WafflePro® Express® to EdgeCraft Corporation, where the cost of repair or electrical or mechanical adjustment can be estimated before the repair is undertaken. If failure occurs within the warranty period there may be no charge.

Please include your return address and a brief description of the problem or damage to the waffle maker on a separate sheet inside the box.

Send your sharpener (insured and postage prepaid) to:

# EdgeCraft

World Leader in Cutting Edge Technology®

**EdgeCraft Corporation**

**825 Southwood Road, Avondale, PA 19311 U.S.A.  
Customer Service (800) 342-3255 or 610-268-0500**

**[www.chefschoice.com](http://www.chefschoice.com)**

This product may be covered by one or more EdgeCraft patents and/or patents pending as marked on the product.

Chef'sChoice®, EdgeCraft® and the overall design of this product are registered trademarks of EdgeCraft Corporation, Avondale, PA.

Conforms to UL Std. 1083 Certified to CAN/CSA Std. C22.2 No. 64-M91

© EdgeCraft Corporation 2011

F11 2011-63

Printed in China.

W840002